

FULL HOUSE ♦ SUPPLY



PRODUCT CATALOG



Easy to Order



PHONE YOUR ORDER

Call Toll-Free
1-800-325-8352

EMAIL YOUR ORDER

supply@full-house.com

FAX YOUR ORDER

24-Hour Fax
1-321-752-8116

MAIL YOUR ORDER

Full House Company
320 North Drive
Melbourne, FL 32934
www.full-house.com



NEED IT QUICK?

We Ship International, Overnight,
2nd Day and 3-Day Select.



Set-up & Training
Service Programs
Lease Programs
Rebuilt Machinery
Trade-Ins
Replacement Parts
Custom Projects

SHOP LAYOUT

Full House offers assistance in shop layout and material flow. With years of experience in over 1,000 door shops, we can help you layout your shop for maximum efficiency.



We are excited to launch the First Edition of Full House Supply catalog. You will find all the necessary items needed to startup and maintain a successful door and millwork company. Full House strives to provide this catalog to help improve your productivity, quality, safety and bottom line.

Full House Company is located in Melbourne, Florida and has been supplying the Pre-Hung Door Industry since 1981. We have grown over the years through innovation and the ability to adapt to the changing market. With a knowledgeable staff and experience in over 1,000 door shops worldwide, we are dedicated to listening to your needs and helping to direct you to the proper solution. Whether you're a small startup or a major corporation, we are here to help our customers from start to finish.

Here at Full House, we have spent a tremendous amount of time ensuring that only the highest quality products have been included in this catalog. Please let us know if there are any additional products that you would like to see included next year.

We look forward to working with you!



FHS
FULL HOUSE ♦ SUPPLY

Table of Contents



FULL HOUSE MACHINERY 4-27

Marquise.....	4
Door Loader.....	7
Beveler/Sizer.....	8
Assembler.....	9
DTS.....	10
Finisher.....	11
Diamond 3001M.....	13
Backsaver Series.....	14
Screwfeeder.....	15
Dust Vacuum System.....	15
Strike Jamb Router.....	16
Trimmer.....	17
Single Gun Stop Stitcher.....	18
Flow Thru Stop Stitcher.....	19
Hanger Exterior Door Assembly System.....	20
Double Door Assembly Table.....	22
Swinger.....	23
Hinge Jamb/ Door & Jamb Router.....	24
Door Stacker.....	25
Weather Strip Machine.....	25
Tilt/Assembly Tables.....	26
Roller Conveyors/Tables.....	27

MACHINES 28-32

Table Saws.....	28
Planer & Jointer.....	29
Band Saws.....	30
Shaper & Sanders.....	31
Panel Saws.....	32

DOOR & JAMB TOOLS 33-36

Lock Boring Jigs, Mortiser & Templates.....	33
Bore Master Kits.....	34
Kwik Drill.....	35
Latch, Strike & Hinge Templates.....	36

CUTTERS & BITS 37-45

Lock Bits.....	37
Latch & Door Lite Bits.....	38
Router Bits.....	39
Hole Saws & Pilot Drill.....	42
Jobbers, Spade, Counter Sink & Auger.....	43
Insert Bits.....	44
Insert Knives, Insert Bit Holders, Slotting Cutters.....	45

POWER TOOLS 46-61

Table & Radial Saws, Sander Grinder.....	46
Jig Saws & Blades.....	47
Miter Saws & Blades.....	48
Circular Saws & Blades.....	49
Reciprocating Saws & Blades.....	50
Cordless Finish Nailers.....	51
Routers & Shaper Table.....	52
Plunge Routers & Cut-Out Tools.....	53
Laminate Trimmers.....	54
Planers.....	55
Drills.....	56
Sanders.....	58
Cordless Vacuums and Lights.....	60
Battery Packs & Chargers.....	61

PNEUMATIC TOOLS 62-71

Air Compressors.....	62
Air Nailers, Staplers & Fasteners.....	64
Air Screw Drivers.....	66
Air Drills.....	67
Air Sanders.....	68
Air Mini Saws, Grinders & Palm Grip Driver.....	69
Air Hose and Accessories.....	70

HAND TOOLS 72-80

Master Sets.....	72
Wrench, Hex Key & Screwdriver Sets.....	73
Glue & Staple Guns, Hammers, Mallets & Pry Bars.....	74
Planes, Files, Chisels & Awls.....	75
Clamps.....	76
Utility Knives, Wall Sensors & Calculators.....	78
Measuring Tools.....	79
Tool Storage.....	80

MATERIAL HANDLING 81-101

Lock Cage.....	81
Van Racks.....	82
Truck Racks.....	83
Door Carts.....	84
Door Racks/ A-Frame Racks.....	85
Cantilever Rack System.....	86
Pallet Racks.....	87
Racks & Shelves.....	88
Carousels, Stands & Ladders.....	90
Carts & Dollies.....	91
Dockplates, Ramps & Dock Lifts.....	92
Pallet, Hand & Platform Trucks.....	94
Hoppers & Carts.....	96
Packaging & Shipping Solutions.....	98

SHOP & SAFETY SUPPLIES 102-114

Dust Collector & Supplies.....	102
Air Circulators.....	104
Vacs, Brooms & Matting.....	105
Brush Sets.....	106
Adhesives, Sealants & Fillers.....	107
Tape.....	108
Gloves.....	109
Protective Eyewear, Face-Shield & Hats.....	110
Ear Plugs, Knee Pads, Respirators, Back Support.....	111
Electrical.....	112
Lockouts & Signs.....	113
First Aid & Coolers.....	114

MODEL NUMBER INDEX 115-119

PRODUCT INDEX 120-121

TERMS AND CONDITIONS 122

ORDER FORM 123

LINE CARD 124

Marquise

DOOR AND JAMB MACHINE



The **Marquise** is designed for residential and commercial door shops that need both a fast and flexible door machine. It is designed with heavy duty components and the latest in technology, so that you can consistently produce high quality door units. The **Marquise** also helps your bottom line by producing each unit with the least amount of labor.

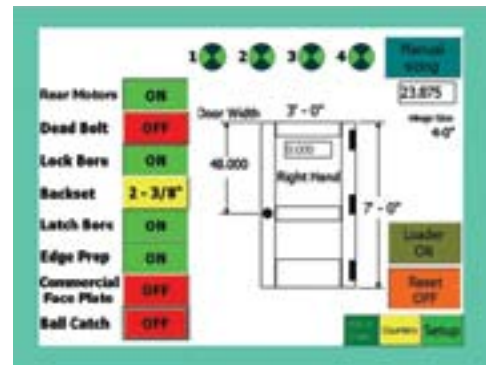

12" Touch Screen

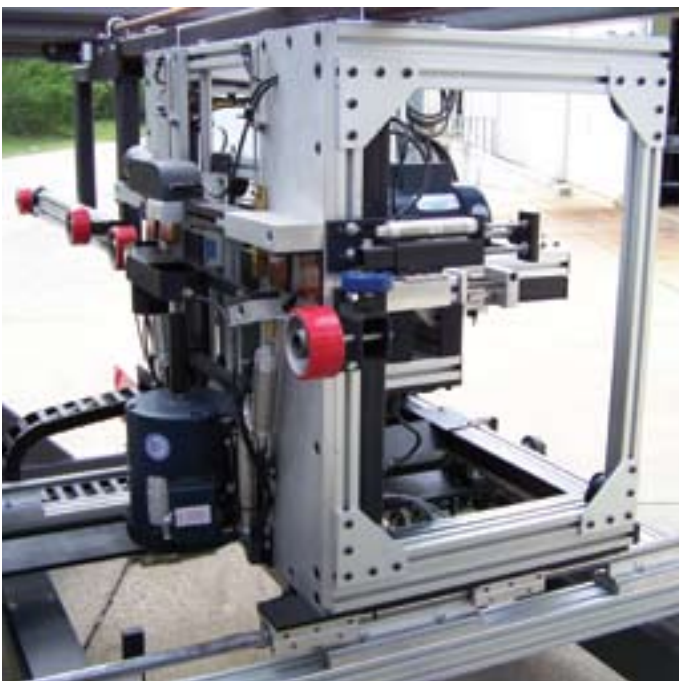

Marquise Lock Drill Unit



Automatic Hinge Routing

INNOVATIVE

- ◆ First horizontal door machine to combine both speed and flexibility.
- ◆ Siemens PLC & Operator Touch Screen
- ◆ Stores door and jamb settings for single touch recall.
- ◆ User passwords can restrict operators access.
- ◆ Help screens and built in diagnostics aid the operator with troubleshooting.
- ◆ Optional Internet Service Package allows online service of the machine.
- ◆ The machine can be upgraded in the future as new features become available.

VERSATILE

- ◆ Custom house packages are produced as efficiently as stock doors.
- ◆ Will machine 6'8" and 8'0" doors and jambs. (7'0" is optional)
- ◆ Automatic width indexing for doors 1'0" to 4'0".
- ◆ Door thickness can range from 1 3/8" to 1 3/4". (2 1/4" is optional)
- ◆ Interior/exterior wood and fiberglass doors are accommodated.
- ◆ Doors with raised moulding on one or both sides can be processed.
- ◆ Auto-tilt for square edge and double beveled doors.
- ◆ Automatic lock and deadbolt boring.
- ◆ Machines flat jambs, split jambs, exterior rabbetted jambs and mull posts.
- ◆ Will machine hinge jambs ranging from 2 1/2" to 14" in width.

QUALITY

- ◆ Clamp up feature ensures consistent backset on door and jamb.
- ◆ Flush hinge mortising on square edge doors and double beveled doors.
- ◆ Auto tilt from 0 to 3 degrees results in flush hinges.
- ◆ Self centering latch bore is always centered within the faceplate mortise.
- ◆ Pre-drill units are used to eliminate splitting door and jamb.
- ◆ Heavy duty clamps straighten hinge jamb prior to machining.
- ◆ Soft non-marking rollers and clamp pads are used to eliminate damage.
- ◆ The computer and digital timers are used to maintain proper cutting speed.
- ◆ Dust shrouds and auto blow offs eliminate the build up of saw dust.

SPEED

- ◆ Automatic door loading, positioning and ejecting is standard.
- ◆ Instantly change the setup of the machine.
- ◆ All 4 hinges on the door and jamb are machined in 6 seconds.
- ◆ Automatic pre-drilling is accomplished in 5 seconds.
- ◆ Six shooter applies the hinge and all six screws in 6 seconds.
- ◆ Complete lock bore is finished in 19 seconds.
- ◆ Quickly run house packages to order or build to stock.
- ◆ Door Counters are useful in determining the productivity of your shop.
- ◆ All types of doors are processed at the same high speed of up to 60 doors/hour.

Full House engineers can access the machine via the internet to monitor settings or download new programs.

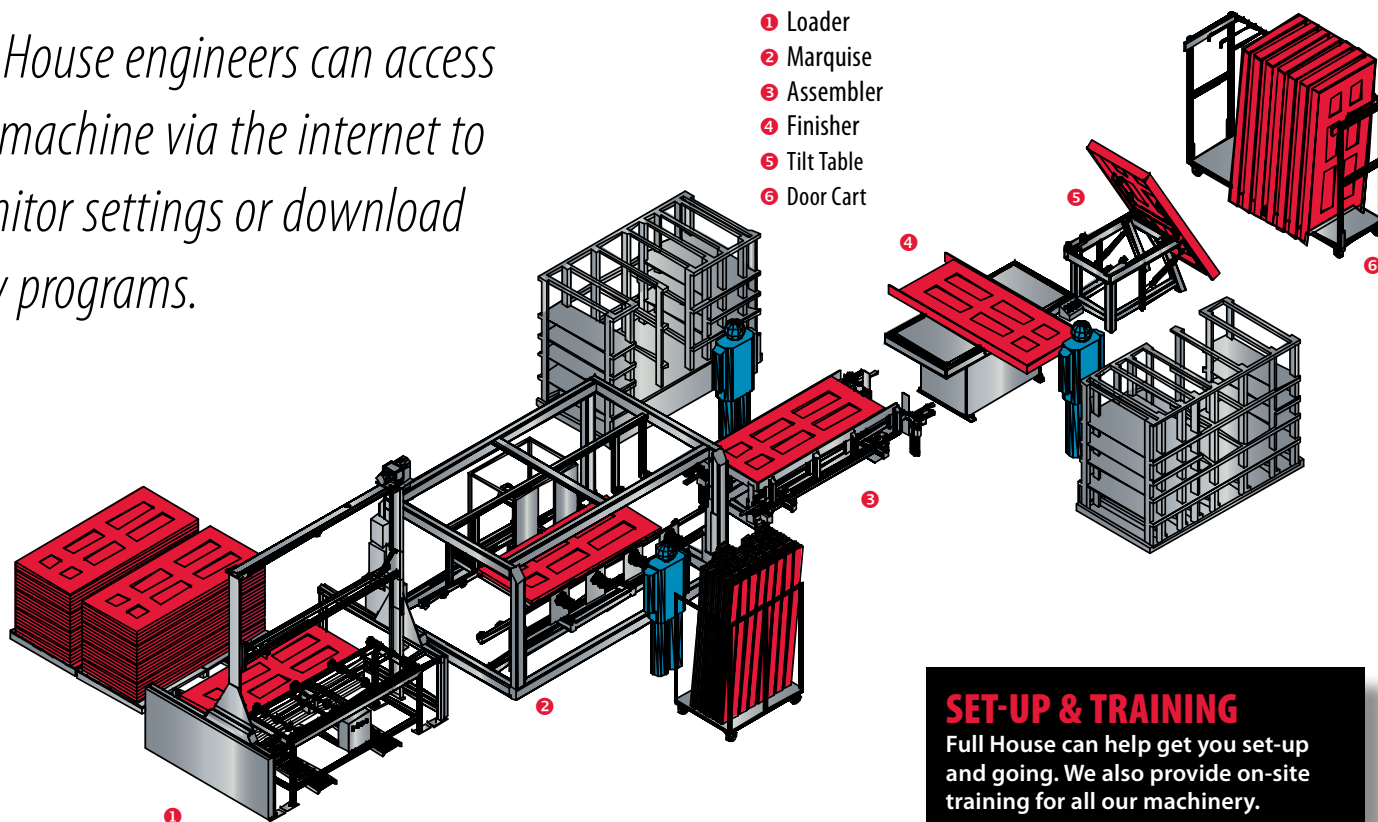

SET-UP & TRAINING

Full House can help get you set-up and going. We also provide on-site training for all our machinery.

MARQUISE CONTINUED

AVAILABLE OPTIONS

These options can be purchased with your Marquise or added later. New options will be designed to work with existing machines.

- A. Auto Tilt Hinge Routers:** Instantly switch between 0 & 3°. Mortises flush hinges on both straight and double beveled doors. (Standard machine is fixed at either straight or 3°.)
- B. Deadbolt Bore:** Automatically bores deadbolts on 6'8" & 8'0" doors.
- C. 7'0" Door:** Includes hinge pattern, lock bore and deadbolt location for 7'0" doors.
- D. Pre-drill:** Pre-drill unit moves to each position and drills six 7/64" holes simultaneously for a 3 1/2" hinge. Units are also available for 4" and 4 1/2" hinges.
- E. Screwfeeder:** Automatically feeds hinge screws and includes a quick change bowl for easily switching screw colors.
- F. Ball Catch Drills:** Includes two complete units for boring the top of doors for right or left hand ball catches. The units drill during the normal cycle time.
- G. Pre-drill System:** All 24 holes are automatically drilled in 5 seconds following the hinge routing.
- H. Custom Lock Positioning:** Digital Integration for infinite lock and deadbolt locations
- I. Hi-freq Routers:** (4) Heavy duty hinge and (1) faceplate routers with drive units. These industrial routers are quieter and will last longer than standard models.
- J. Hinge applicator:** The operator places a 3 1/2" hinge on the magnetic indexing fixture and presses a button, the hinge applicator feeds all six screws and applies the hinge in approximately 6 seconds. This option saves the operator a tremendous amount of time and energy. The hinge applicator is also available in an eight shooter for 4" hinges. Both hinge applicators come standard with a quick change bowl for easily switching screw colors.
- K. Beveler/Sizer:** Integrated sizing system works from the Marquise's touch screen and includes an automatic buffer table to maximize production.
- L. 2 3/4" Backset:** Instantly switch between 2 3/8" and 2 3/4" backset. (Does not require changing the backup blocks)
- M. Half Bore:** Automatically machine for a closet pull or third deadbolt for apartment buildings.
- N. Pass Thru Hinges:** Mortise exterior doors for pass thru hinges.
- O. Commercial Faceplate Mortise:** Add a second faceplate size up 1 1/8" x 2 1/4".
- P. Internet Service Package:** The Marquise can be monitored remotely via the internet.
- Q. Dust Collection System:** 5 HP system with auto start.
- R. Deep Pocket Mortising:** Custom built lock drill module including Hi Frequency router and computer controlled (X,Y,Z) drives. Used for Commercial and European locks.



Hinge Applicator - Six Shooter

Pre-drill Units
(Available in 3 1/2", 4" or 4 1/2")

Six Shooter Stand



Automatic Ball Catch Drills



Heavy Duty Clamping System

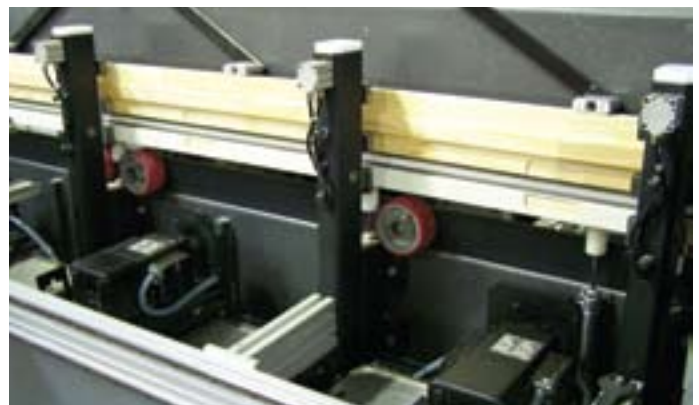

High Frequency Routers

Door Loader



The **Marquise Door Loader** is completely automatic and will adjust to any width of door from 1' to 4' and up to 8' in height. The loader will pick the top door from a stack and place it on the infeed table. The door is then automatically fed into the Marquise at the proper time.



MACHINE FEATURES

- ◆ Automatically adjusts to any height, width and thickness of door
- ◆ Accommodates a door stack height of up to 7'
- ◆ Will pick up heavy doors up to 2 1/4" thick
- ◆ No adjustment needed to pick up doors with raised moulding
- ◆ Optional floor conveyors can be added to allow staging of multiple orders
- ◆ Empty pallets are removed from the front of the machine so material flow is not interrupted
- ◆ The loader can be set up to feed either right or left depending on shop layout
- ◆ The entire operation of the loader can be controlled electronically from the Marquise's touchscreen
- ◆ The loader can run in either manual or automatic cycle

CAPABILITIES

- Types of doors:** Interior and Exterior doors
(Will accommodate raised moulding)
- Height:** Up to 8'
- Width:** 1'0" to 4'0"
- Thickness:** Up to 2 1/4"

SPECIFICATIONS

- Machine Size:** 10'L x 8"W x 11'H
- Electrical Requirements:** Runs off Marquise
- Air Requirements:** 7 CFM @ 90-100 PSI
- Shipping Weight:** 2000 lbs.

Beveler/ Sizer

The **Horizontal Beveler/Sizer** is completely automatic and can be used either inline with the Marquise or as a stand alone machine. This machine's heavy duty cutter head will bevel the lock side of the door to 3°. The machine will also ease the edges of the door for a smooth factory finish. An optional inline belt sander can be added.



Heavy Duty 5 HP Motor



Quick change blades, bits



MACHINE FEATURES

- ◆ Auto on/off
- ◆ Electronically controlled sizing is quick and accurate
- ◆ Bevels and sizes doors up to 2 ¼" thick
- ◆ Accommodates doors with raised moulding on both sides
- ◆ Bevels and sizes doors 1' to 4' width
- ◆ Dust collection hookup is standard
- ◆ The digital integration package allows the machine to be controlled from the Marquise's touchscreen
- ◆ The automatic buffer table increases the productivity of the entire door line.
- ◆ Options:
 - Inline belt sander
 - Digital Integration
 - Automatic Buffer Table

CAPABILITIES

Types of doors:	Interior and Exterior wood doors (Will accommodate raised moulding)
Height:	Any
Width:	1'0" to 4'0"
Thickness:	Up to 2 ¼"

SPECIFICATIONS

Machine Size:	8'L x 5'W x 4'H
Electrical Requirements:	208V - 230V, 3 Phase, 13 AMP 115V, 1 Phase, 4 AMP
Air Requirements:	10 CFM @ 90-100 PSI
Shipping Weight:	2000 lbs.

Assembler

AUTOMATIC ASSEMBLY MACHINE

The Full House **Assembler** is used to quickly and accurately assemble interior and exterior doors and jambs. Its unique method of clamping and squaring the jambs results in a tight fit without putting pressure on the door.



Jambs are securely clamped during stapling.



A duplex nail or a door plug is used for shipping.

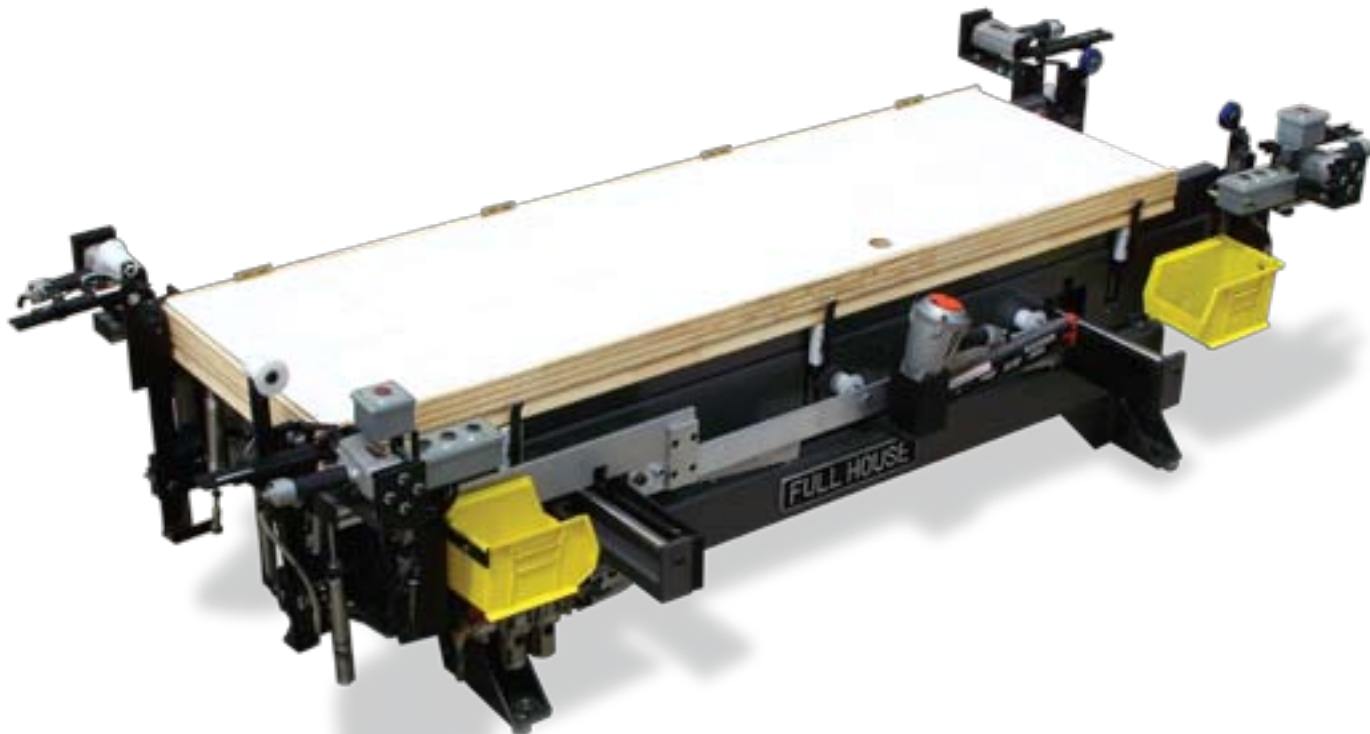

MACHINE FEATURES

- ◆ Simple to operate
- ◆ The assembler will consistently build a great quality door unit.
- ◆ The door and hinge jamb are moved into the machine on non-marking rollers.
- ◆ The operator places the strike and head jamb into the machine ready for clamping.
- ◆ With the push of a button the entire unit is clamped up square.
- ◆ The clamped header signals which staplers need to fire for either a right or left hand door.
- ◆ The unit is completely pre-hung in less than 10 seconds and is ejected on a second set of non-marking rollers.
- ◆ A rotating index bar allows quick change of up to 4 pre-set staple patterns. The index bar controls all 4 staple guns reducing setup time when switching between jambs.
- ◆ The unique clamping system handles doors up to 8' in height and from 1' to 4' in width.
- ◆ Custom gun mounts are machined to match any brand of fastener.
- ◆ An optional duplex nailer can be added for keeping the door closed.
- ◆ The Assembler is compatible with any vertical or horizontal door machine.

CAPABILITIES - DOORS

- Types of Doors:** Any type of wood, steel or fiberglass doors Including raised molding on both sides
- Height:** Up to 8'
- Width:** 1' - 4'
- Thickness:** 1" - 2 1/4"

CAPABILITIES - JAMBS

- Types of Jambs:** Flat, Split, Single or Double rabbitted
- Height:** Up to 8'
- Width:** Up to 7 1/4"
- Thickness:** 1/2" - 1 1/2"

SPECIFICATIONS

- Machine Size:** 11'L x 7'W x 3'H
- Electrical Requirements:** 120 V, single phase @ 15 amps.
- Air Requirements:** 8 - 12 CFM @ 100 PSI.
- Shipping Weight:** 1500 lbs.

DTS - Door Transfer System

Is applying casing to the door unit slowing you down?

Let us help design and build a custom streamlined solution for your new or existing door line. **Casing and packaging will no longer be your door line's bottleneck.**



Dual belt conveyors and pop up rollers



Shown with 3 finisher/tilt work stations for applying door casing

MACHINE FEATURES

- ◆ Two industrial belt conveyors transfer door units from the assembler to individual work stations.
- ◆ Heavy duty pop-up rollers allow unit to easily slide from the DTS to each finisher
- ◆ Will keep up with the fastest door lines on the market
- ◆ Number of workstations depends on the required production
- ◆ Individual call buttons allow operators immediate access to the next door

CAPABILITIES

Types of doors:	All Interior and Exterior
Height:	Up to 8'
Width:	Up to 4'
Thickness:	Up to 2 1/4"

SPECIFICATIONS

Machine Size:	18' L x 6' W
Electrical Requirements:	120 V
Air Requirements:	3.5 CFM @ 90-100 PSI

Finisher

CASING & PACKAGING MACHINE

The **Finisher** is designed to put the finishing touches on interior and exterior pre-hung door units. The unique design reduces labor and damage by allowing one operator to rotate and flip the pre-hung unit. Optional tilt-up feature eliminates the need for a separate tilt table.



Holster with Air Disconnect



MACHINE FEATURES

- ◆ The Finisher pneumatically lifts and rotates the pre-hung door unit allowing one operator to apply casing to all sides of the door unit and then orient the head in the right direction for packaging and shipping.
- ◆ Two belts aid in the flipping of the pre-hung door unit.
- ◆ Allows one operator to efficiently case both sides.
- ◆ Easily flip the unit to apply head stop.
- ◆ Holsters and air connections have been added for staple guns.
- ◆ Storage under the table for extra staples and materials
- ◆ No need for lifting or walking around the table to finish the unit.
- ◆ High production shop might use multiple finishers per door line.



Tilt Table Option

SPECIFICATIONS

- Machine Size:** 8'L x 4'W x 3'H
Height is adjustable to match height of door line
- Electrical Requirements:** 120 V, 10 amps
- Air Requirements:** 1.5 CFM • Number and style of fasteners will increase air consumption
- Shipping Weight:** Approx. 800 lbs.

REPLACEMENT PARTS
Need a replacement part?
Full House's knowledgeable service department can help you find what you are looking for.

Diamond 3001M

"MILLENNIUM EDITION"

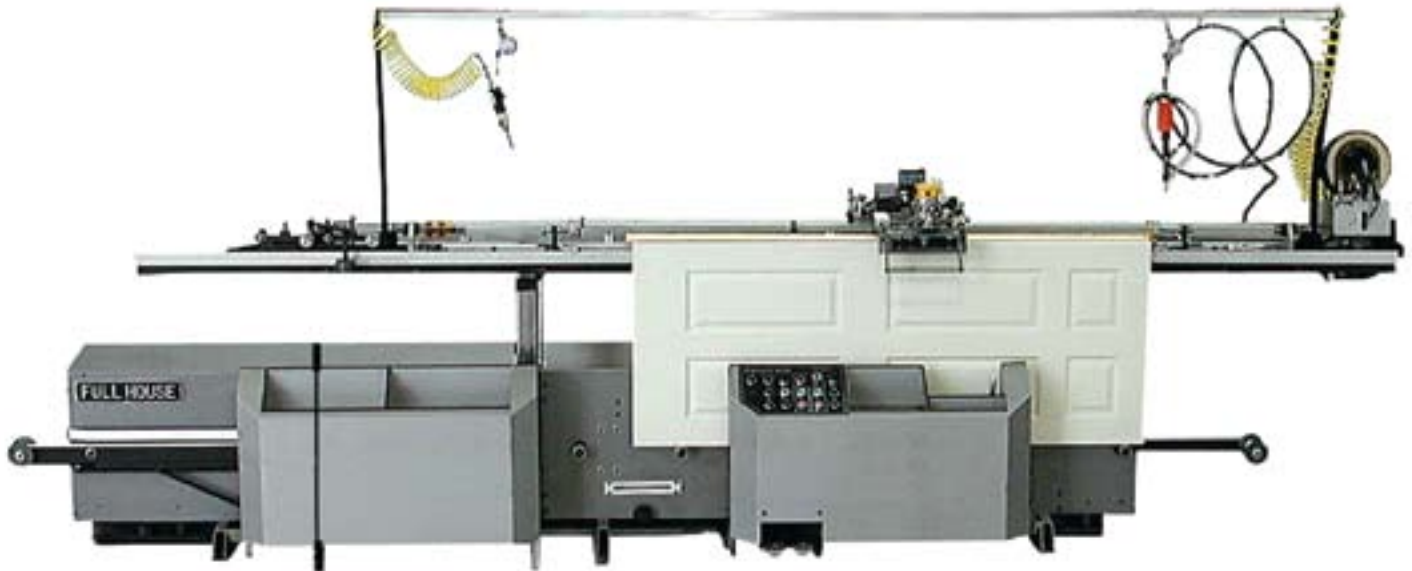

THE MOST VERSATILE PRE-HUNG DOOR SYSTEM IN THE WORLD

The Diamond 3001M is three door machines in one. The 3001 machines wood, steel and fiberglass doors. Ease of changeover means your machine will be producing product, not sitting idle while you measure or make adjustments. And the superior design of the Diamond Door Machine helps you construct the highest quality doors while conserving your most precious resource — time.



Heavy Duty Hinge Router Carriage



Digital Readout for Custom Hinge Locations



Beveler/Sizer & Dual Edge Easers



Dual Lock Drills with Automatic Edge Prep



User-Friendly Control Panel



Electrical Box with Operators Manual

MACHINE FEATURES

- ◆ Precision machining of wood, steel and fiberglass doors up to 4' x 9' and jambs up to 10 1/2." Will process doors up to 2 1/4" thick with raised moulding on one or both sides.
- ◆ Hinge locations and door sizes can be changed in seconds, which makes the Diamond 3001 ideal for shops producing residential, commercial, architectural and fire-rated doors.
- ◆ Automatically adjusts from interior to exterior doors. House jobs can be run with no changeover.
- ◆ The Hinge Router Carriage travels smoothly on a Linear Rail System. This provides accurate placement of the hinges.
- ◆ Digital Readout is located on the hinge router carriage. This fractional display is ideal for specials and replacements.
- ◆ Rotating Hinge Bar has eight preset hinge patterns. The operator can change hinge locations in seconds. No need to invest in additional bars for each different hinge pattern.
- ◆ Double Bevel Router Carriage will mortise for flush hinges on square edge and double beveled doors.
- ◆ Adjustment for jamb thickness is controlled by a switch on the hinge router carriage.
- ◆ Changing from 5/8" to 1/4" hinge mortise is accomplished in seconds by using the quick-change router kit.
- ◆ Complete lock boring is automatic and occurs while the operator mortises for the hinges. Drilling for the lock, latch, and mortising for the rectangular faceplate is accomplished without repositioning the door.
- ◆ Changing lock bore backset from 2 3/8" to 2 3/4" is automatic by flipping a switch. It is no longer necessary to change back-up blocks.
- ◆ Power-fed 5 HP Beveler/Sizer. Cutter-head rotates in the same direction as the door is moving for a perfect climb cut. Dual-edge relief routers ease the edges of the door resulting in a smooth factory finish.
- ◆ Infinite width indexing allows doors to be sized and machined to any specified width.
- ◆ Quick change door and jamb stop. No measuring is necessary to change stops, all stops are slotted for a quick change.
- ◆ Quick change templates for any hinge size.

- ◆ Separate two-speed lock drill module for steel doors and deadbolts. Allows a lower R.P.M. for boring steel doors and a higher R.P.M. for boring wood doors.
- ◆ Full dust collection hook-ups are provided for the hinge router, bevel/sizer, and lock boring module. An additional floor sweep is included for cleanup purposes.
- ◆ Options:
 - Automatic In-line Screwfeeder
 - Air Pre-drill Kit

CAPABILITIES

	DOORS	JAMBS
Width:	1'6" to 4'	3 1/2" to 10 1/2"
Height:	Up to 9'	Up to 9'
Thickness:	1 3/8" to 2 1/4"	1/2" to 1 1/2"
Butt Sizes:	3 1/2" , 4" , 4 1/2" , 5"	
Hinge Locations:	Unlimited	
Butt Radius:	1/4" , 5/8"	
Lock Backsets:	2 3/8" , 2 3/4"	
Faceplate Routing:	Up to 1 1/8" x 2 3/4"	
Capacity Rate:	30 doors per hour	

SPECIFICATIONS

Machine Size:	18'L x 3'W x 8'6"H
Electrical Requirements:	230 v 3Ø, 230 v 1Ø, or as required
Air Requirements:	Min. 8 CFM @ 100 PSI
Shipping Weight:	Approx. 3500 lbs.

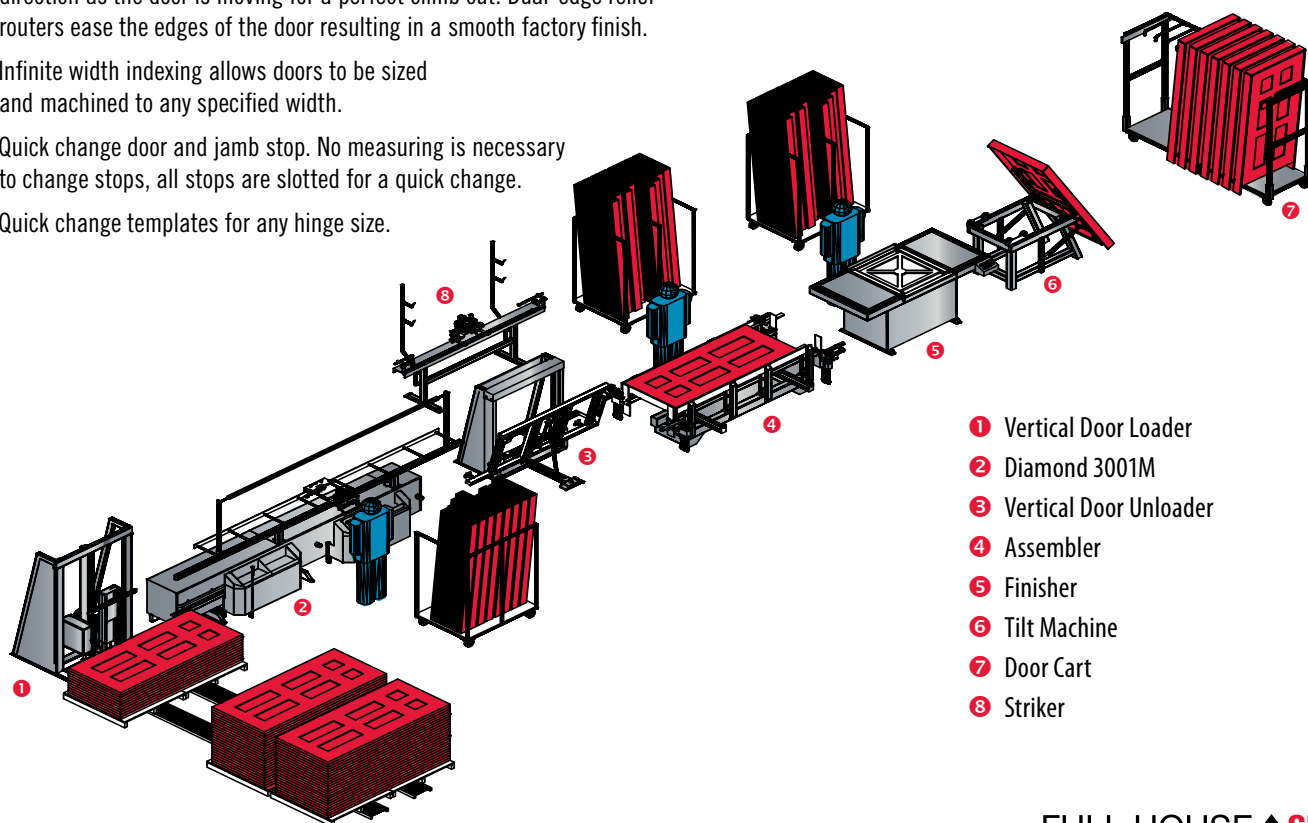

- 1 Vertical Door Loader
- 2 Diamond 3001M
- 3 Vertical Door Unloader
- 4 Assembler
- 5 Finisher
- 6 Tilt Machine
- 7 Door Cart
- 8 Striker

Backsaver Series

The **Backsaver Loader** and **Unloader** saves the operator precious time and energy. They streamline the material flow in and out of your vertical door machine.

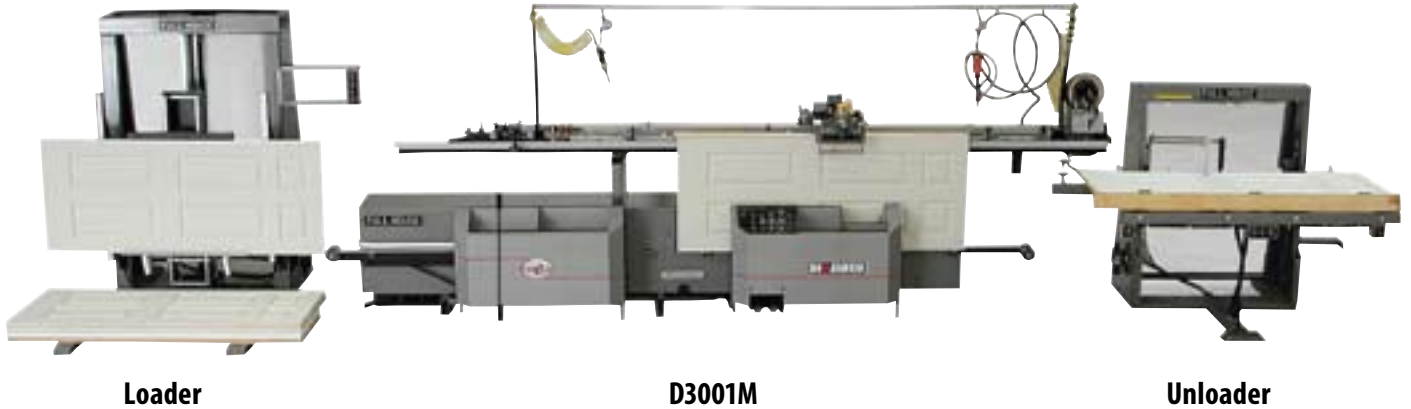

Doors are individually picked from a stack to reduce damage.

Doors are transferred to an assembly machine or tilted up for easier handling.

MACHINE FEATURES

- ◆ The Loader automatically picks the top door from a stack, lifts and then turns the door to a vertical position, ready to be fed into the vertical door machine.
- ◆ The Unloader transfers the door to an assembly table or tilts to a vertical position for ease of handling to a cart or rack.
- ◆ Both machines will easily handle heavy doors, including solid core, MDF and doors with impact glass.
- ◆ Both machines will accommodate doors with raised moulding on one or both sides.
- ◆ The Backsaver Series saves the operator time and allows for more output through the vertical door machine.
- ◆ Helps reduce back related injuries and damage from unnecessary material handling.
- ◆ They can be used with any brand of vertical door machine.
- ◆ Both machines are completely air operated for ease of set-up and low operation costs.

CAPABILITIES

	Loader	Unloader
Width:	Up to 3'0"	Up to 4'0"
Height:	Up to 9'0"	Up to 9'0"
Thickness:	Up to 2 1/4"	Up to 2 1/4"
Stack Height:	Up to 51"	NA

SPECIFICATIONS

	Loader	Unloader
Machine Size:	8'L x 7'W x 7'6"H	6'L x 7'W x 6'H
Air Requirements:	Min. 8.5 CFM @ 90 PSI	Min. 8.5 CFM @ 90 PSI
Shipping Weight:	Approx. 1250 lbs	Approx. 900 lbs

Automatic Screwfeeder

Specially designed to save time during hinge application



MACHINE FEATURES

- ♦ In-line screwdriver for vertical door machines.
- ♦ Direct drive pistol grip screwdriver for horizontal door machines.
- ♦ Driver Jaws made of tool steel, hardened to 60 Rockwell C for long life.
- ♦ 10" or 12" feeder-bowl available.
- ♦ Patented escapement mechanism.
- ♦ Optional quick change bowl for easily switching screw colors.

SPECIFICATIONS

Electrical Requirements: NA
Air Requirements: 10 CFM @ 90-100PSI
Shipping Weight: 50 lbs.



Quick change bowl for switching screw colors



Self Centering Jaws

Dust Vacuum System



Industrial motor and remote start/stop



4" Hose Connects

MACHINE FEATURES

- ♦ Practical, Fully Mobile Dust Collectors.
- ♦ Precision spin-balanced impellers for smooth operation and minimal noise.
- ♦ Single stage design for powerful and economical operation.
- ♦ Four swivel castors allow total mobility.
- ♦ Micron poly-cotton bags are washable for long service life.
- ♦ All models include basic machine, motor & switch, micron bags, base castors and instruction manual.
- ♦ Optional: Single Phase, 208/220V

SPECIFICATIONS

Motor Size:	3 HP	5HP
Electrical:	220V, 3 Phase	220V, 3 Phase
Bag Volume:	10.8 ft ³	26 ft ³
Air Volume:	2800 CFM	4820 CFM
Hose Size:	4" or 8"	4" or 8"
Shipping Weight:	363 lbs.	616 lbs.

Strike Jamb Router

The **Diamond Strike Jamb Router** is a great compliment to any door machine. A foot operated pedal pneumatically clamps the material and starts the router. Many types of strike plates can be mortised by use of quick change templates. With the standard deadbolt adapter the operator can change from a Full Lip Strike to Deadbolt Strike without changing templates. Deadbolt stops are standard.



Quick change stop system



Quick change template



MACHINE FEATURES

- ♦ Jamb Racks above and below the work surface aid in ease of handling material
- ♦ Pre-set deadbolt stops allow a quick and easy processing of exterior jambs.
- ♦ Accurately machines full lip strikes, no lip deadbolts and T-strikes.
- ♦ Quick change stops accommodate flat jambs, split jambs, rabbited jambs, mull posts and headers for ball catches.
- ♦ With a template you can machine hinge pockets
- ♦ Quick change backset stops
- ♦ Quick change bar for switching between 6'8", 7'0" & 8'0" jambs
- ♦ Custom Templates available

CAPABILITIES

Width:	No Limit
Height:	Up to 9'0" (Unlimited without stops)
Thickness:	½" to 1½"
Routing:	Up to 4 7/8". (Custom templates available.)
Machine Capacity Rate:	Over 200 Jambs per hour

SPECIFICATIONS

Machine Size:	8'L x 2'W x 3'6"H
Electrical Requirements:	120 V, Single Phase 10 AMP
Air Requirements:	1.5 CFM @ 90 PSI
Shipping Weight:	Approx. 250 lbs.

Trimmer

DOUBLE END TRIM SAW

The **Trimmer** has the speed, accuracy and versatility to meet the changing demands of today's door shops. The Trimmer will miter casing and brickmold up to 4 1/2" wide. It will square cut or miter door stop. It will even process jambs up to 7 1/4". The best feature is the ease of changeover from one setup to the next.



The Trimmer's positive clamping system results in an exact miter

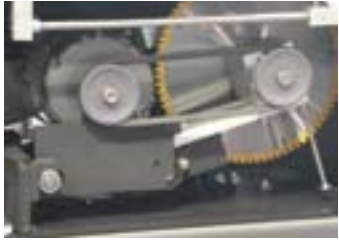

12" 80-toothed Carbide tipped blades cut the material clean and fast



Digital readout for precise lengths

MACHINE FEATURES

- ◆ Process casing, door stop, brickmold and jambs
- ◆ 12" Carbide Tipped Blades process wide material
- ◆ Carriages automatically shift between 45 and 90 degrees
- ◆ Material support fences help straighten the material prior to processing
- ◆ Drop chutes direct off cut away from working surface
- ◆ Finished material is automatically ejected out the back to a rack or cart
- ◆ **Options:**
 - **Digital Readout:** Lengths are displayed in fractions.
 - **Kerfing:** Machines the corners of casing for metal spline nails.
 - **Jamb Cut Down:** Cuts jambs to length on one end only. Saves end with dado.
 - **Automatic Sizing:** Operator touch screen and servo are added for single touch recall. Lengths can be typed in or selected from up to 200 pre-sets. No need to remember all the different lengths. Program ensures the saw keeps consistent lengths. Makes training new employees much easier. Material counters are also included.

CAPABILITIES

- Material:** Door Stop, Casing, Brickmold, Jambs
- Length:** 18" to 98"
- Width:** Up to 7 1/4" (90°)
Up to 4 1/2" (45°)
- Thickness:** Up to 1 1/2"

Processes up to 20 pieces per minute

SPECIFICATIONS

- Machine size:** 12'L x 3'W x 3'6"H
- Electrical Requirements:** 115v single phase, 20 amps
208-230v 3 phase, 12 amps
- Air Requirements:** 4.5 CFM @ 90 PSI
- Shipping Weight:** 1500 lbs.

Single Gun Stop Stitcher

The Diamond **Single Gun Stop Stitcher** applies stop to flat jambs. The machine accommodates any type of material.

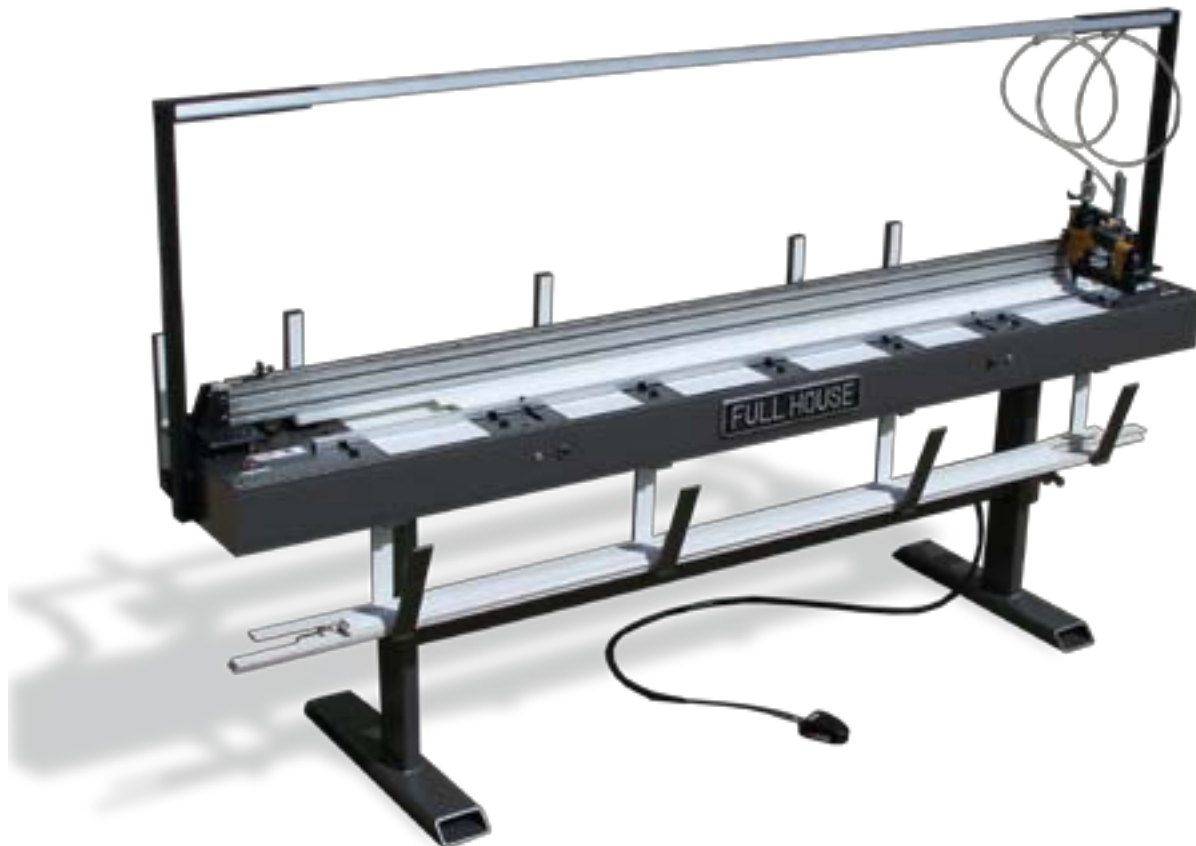

MACHINE FEATURES

- ◆ Jambs are securely clamped in place.
- ◆ No adjustment is necessary for processing different length jambs up to 8'.
- ◆ Will process square or mitered door stop.
- ◆ Stop guide straightens and aligns warped stop prior to applying.
- ◆ Quick change stops are included for switching the backset for 1 3/8" to 1 3/4" doors.
- ◆ End stops are referenced from the inside of the dado. This ensures correct alignment of the stop even if the length of dado varies.
- ◆ Special stops can be included for applying stop to head jambs.
- ◆ Finished jambs are ejected to a material rack.
- ◆ Custom gun mounts are machined to match most manufacturers staplers or nailers.
- ◆ Extended magazine for the fastener is recommended to help minimize downtime for reloading.

CAPABILITIES

Jamb Length:	Up to 8'
Jamb Width:	4" to 7 1/4"
Jamb Thickness:	Up to 3/4"
Stop width and thickness:	Adjustable to match most sizes and profiles
Backset:	Adjustable
Staple spacing:	Infinite
Production rate:	Up to 6 pieces per minute

SPECIFICATIONS

Machine Size:	8'L x 3'W x 4'H
Electrical Requirements:	115v single phase Standard cord and plug
Air Requirements:	100 PSI
Shipping Weight:	Approximately 600 lbs.

Flow Thru Stop Stitcher

The Diamond **Flow Thru Stop Stitcher** automatically applies stop to flat jambs. The machine accommodates pine, hardwood and MDF material. It is designed for speed, easy operation and trouble-free material handling.



Accommodates all brands of staplers or brad nailers.



MACHINE FEATURES

- ◆ Process two jambs simultaneously or one at a time.
- ◆ Will process square or mitered stops without adjustment
- ◆ Fasteners are placed 2" from both ends and every 11" between. No adjustment is necessary for processing different jamb lengths.
- ◆ Jamb stops are referenced from the inside of the dado. This ensures correct alignment of the stop even if the lengths of dado's vary.
- ◆ Quick change stops for switching backset for 1 3/8" to 1 3/4" doors.
- ◆ Special stops are included for headers
- ◆ Automatically powered using a non-marking wheel
- ◆ Finished jambs are ejected to material racks.
- ◆ Floating gun mounts increase service life of guns
- ◆ Accommodates most manufacturers staplers or nailers. Custom gun mounts are machined to match.
- ◆ Extended magazines are recommended to help minimize downtime for re-loading

CAPABILITIES

- Width of jamb:** 4" to 7 1/4"
- Thickness of jamb:** up to 3/4"
- Stop width and thickness:** Adjustable to match most sizes and profiles
- Backset:** Adjustable
- Staple spacing:** 2" from each end with 11" between staples (custom spacing available)
- Production rate:** up to 20 pieces per minute

SPECIFICATIONS

- Machine Size:** 8' L x 3' W x 4' H
- Electrical Requirements:** 115v single phase Standard cord and plug
- Air Requirements:** 100 PSI
- Shipping Weight:** Approximately 600 lbs.

Hanger- Exterior Door Assembly System



Lite Insertion



Door Flipper



Holsters, Air Connects & Tool Trays



Tilt Up



Loader

HANGER

The Exterior Door Assembly Table (Patent #5,725,205) will handle all types of doors: inswing, outswing, right or left-hand and doors with or without brickmold. The first step in the assembly process is to place the glazed half of the lite insert on the pneumatically operated lift table. The door is then rolled over the top of the lite. By pushing a button, the lite is lifted into the opening of the door and the grille portion of the lite is screwed in place.

The machine then flips the door depending on the hand and swing. While one operator attaches the hinge leaf, the other operator attaches the hinge keeper, strike jamb and door sweep. The operators then work together to attach the door sill. Since the unit is assembled with the hinge pin down, installation of the brickmold is quick and easy. The completed door unit is then automatically tilted in a vertical position for handling onto a door cart or pallet.

LOADER

The Loader automatically adjusts to any width, thickness and height of door and will handle a stack of up to 7' tall. It automatically picks up the top door from the stack and places it on the infeed table and then moves the door into the Hanger at the proper time. Pneumatic operation results in easy installation and lower maintenance costs.

THE MOST EFFICIENT SYSTEM FOR PRE-HANGING EXTERIOR DOORS

The Full House **Exterior Door Assembly System** is designed to systematically and efficiently assemble any brand of steel, wood or fiberglass exterior door units. The complete "System" includes the Loader and Hanger. A Double Door Assembly Table can be added for cost effective production of complex door units. Each machine is a free standing machine, but the greatest "Productivity" is achieved when they are used as a "System."

PRODUCTIVITY.

Two operators assemble doors complete with lites, frame, brickmould, sweep and threshold in less than 3 minutes. Flush or paneled units can be assembled in less than 2 minutes.

PROFITABILITY.

All units are produced systematically for consistency, quality and efficiency, which reduces labor costs.

MAINTENANCE.

The entire "System" is totally air operated for ease of installation and lower maintenance costs.

SAFETY.

Using the "Hanger System" eliminates repetitive lifting which reduces operator fatigue and back related injuries.

CAPABILITIES

	HANGER	LOADER
Width:	2'6" to 3'0" <i>(custom machine available for wide lites and smaller doors)</i>	Singles up to 4'
Height:	Up to 8'	Up to 8'
Thickness:	Up to 2 1/4'	Up to 2 1/4'
Jamb Width:	Unlimited	

SPECIFICATIONS

	HANGER	LOADER
Machine Size:	15'5"L x 3'2"W x 3'5"H	9'10"L x 6'8"W x 10'5"H
Air Requirements:	Min. 30 cu. ft./min. @100 PSI	Min. 30 cu. ft./min. @100 PSI
Shipping Weight:	Approx. 1500 lbs.	Approx. 2000 lbs.

SHOP LAYOUT

Full House offers assistance in shop layout and material flow. With years of experience in over 1,000 door shops, we can help you layout your shop for maximum efficiency.

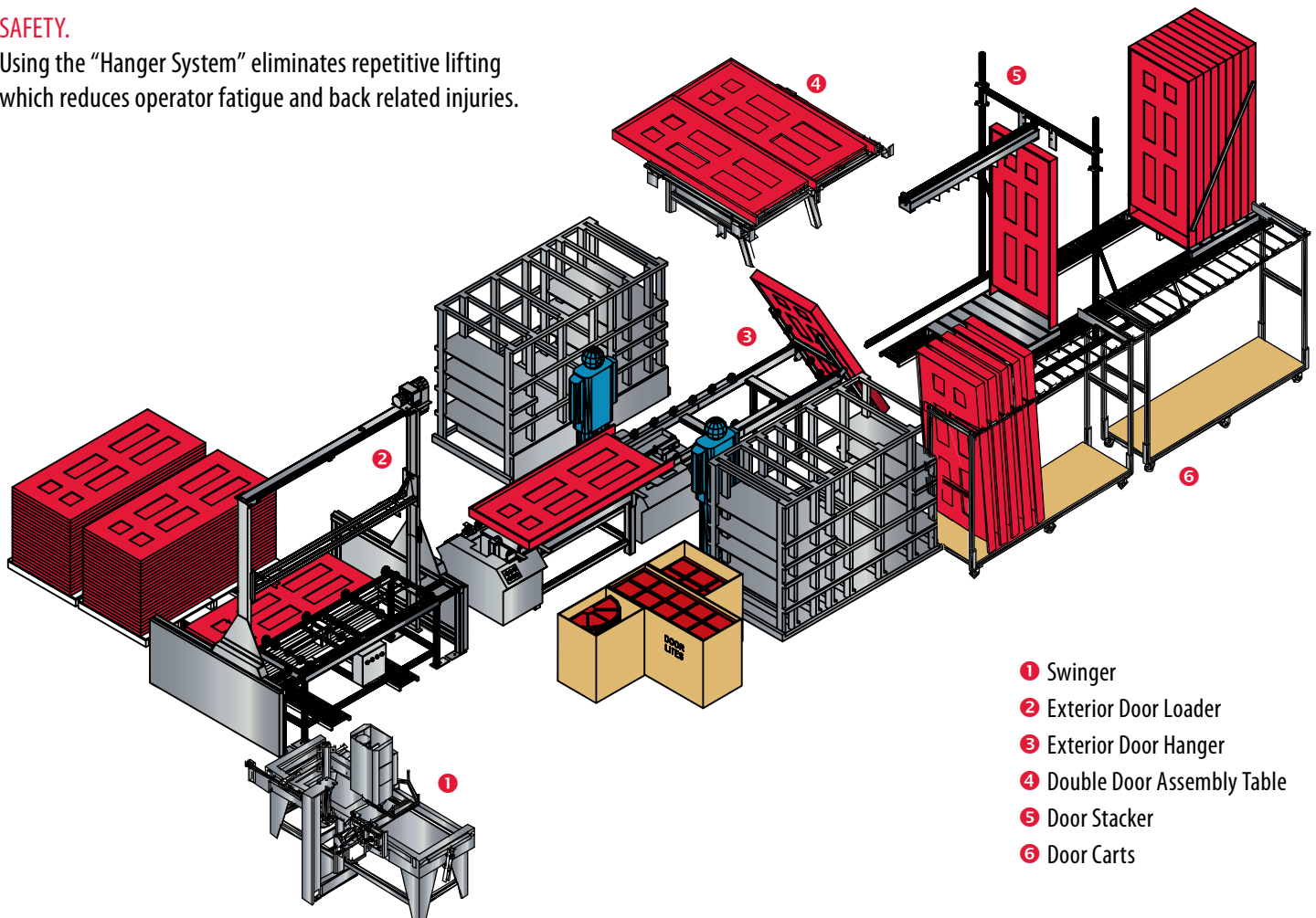

- 1 Swinger
- 2 Exterior Door Loader
- 3 Exterior Door Hanger
- 4 Double Door Assembly Table
- 5 Door Stacker
- 6 Door Carts

Double Door Assembly Table

The **Double Door Assembly Table** gives one operator an accurate, square, pneumatically assisted station to construct various size units. The clamp table accommodates interior and exterior units with or without sidelights. The assembly table is engineered to allow for consistent frame assembly and hardware application at a standard working height. This helps to eliminate the operator's stress and strain. The tilting table feature reduces back related injuries.



Clamps hold jambs square during assembly.



Tilt up helps to eliminate damage and back injuries.



Custom Sizes Available

MACHINE FEATURES

- ◆ The Jamb parts are pneumatically clamped and held securely in position for nailing or screwing.
- ◆ The clamp channels are adjustable for various width units.
- ◆ Double door supports keep unit level during pre-hanging.
- ◆ Adjustable pullouts for sidelites and transoms are included for larger units.
- ◆ Activating the foot pedal, the finished door unit is pneumatically tilted to a vertical position within 6 inches from the floor for easy movement
- ◆ Full House Co. has built several custom tilt tables for various applications. Please contact us for further details.

CAPABILITIES

- Width:** Singles up to 4', Doubles up to 6', Complex units up to 9'
- Height:** Up to 9'
- Doors:** Single with sidelites
(Cont. head & sill or boxed sidelites)
Doubles
Triples

SPECIFICATIONS

- Machine Size:** 7'4"L x 7'4"W x 3'6"H
- Air Requirements:** 80 PSI
- Shipping Weight:** Approx. 500 lbs.

Swinger

DOOR LITE ROUTER

The Full House **Swinger** is used to quickly and accurately process metal, wood and fiberglass exterior doors for custom lites, lock and deadbolt bores, latch bores and faceplate mortises.



Quick change lock template



Optional oscillating bit

MODELS AVAILABLE

- SWINGER** *Window lite cutting only*
- SWINGER I** *Window lite cutting, lock boring, latch boring*
- SWINGER II** *Window lite cutting, lock boring, latch boring, faceplate routing*

MACHINE FEATURES

- ◆ Heavy duty swing arm assembly allows processing of doors up to 4-0 x 8-0. No need to move door or template to machine full lites.
- ◆ Template and door is securely clamped at both ends to prevent damage.
- ◆ Door stops for easy set up of lock and deadbolt height.
- ◆ Full House Co. supplies special tooling for steel, wood and fiberglass doors.
- ◆ Quick change phenolic template allows instant changes of bore size and of backsets from 2 3/8" to 2 3/4".
- ◆ Optional oscillating bit during lite cutout increases bit life.
- ◆ Bottom of machine is left open for portable waste bin.
- ◆ Dust collection can be added for fiberglass doors.

CAPABILITIES

- Door thickness: Up to 2 1/4"
- Door size: Up to 4' x 8'
- Lock bore size: Up to 2 1/8"
- Lock backset: 2 3/8" and 2 3/4"
- Faceplate sizes: Up to 1 1/8" x 2 1/2"

SPECIFICATIONS

- Machine size: 10'L x 7'W x 5'H
- Lock bore motor: 2HP (230v, 3 phase, 6 amp)
- Latch bore motor: 1HP (230v, 3 phase, 3 amp)
- Faceplate router: 25,000 RPM (air router motor)
- Air requirements: 8 CFM @ 100 PSI
- Shipping weight: 1750 lbs.

Hinge Jamb Router/ Door and Jamb Router

The Diamond **Hinge Jamb Router & Door and Jamb Router** are both extremely flexible and very useful machines. The entire top bar is identical to the Diamond 3001M.



MACHINE FEATURES

- ♦ Rotating Hinge Location Bar has four pre-set hinge patterns. Hinge locations can be changed in seconds with no measuring necessary. Color coded stops are used for right and left hand doors and jambs.
- ♦ Hinges can be placed anywhere along the door or jamb.
- ♦ Digital readout can be added for quickly machining custom hinge locations.
- ♦ Quick change door and jamb stops for changing between 6'8", 7'0" and 8'0".
- ♦ Quick change jamb stops for changing between split, flat and rabbeted jambs.
- ♦ Quick change templates for changing hinge size between 3 1/2", 4", 4 1/2" & 5".
- ♦ Will accommodate mull posts.
- ♦ Pneumatic clamping automatically adjusts for jambs up to 10 1/2" wide.
- ♦ Same heavy duty components as the Diamond 3001M router carriage.
- ♦ Double bevel router carriage can be added for machining flush hinges on double beveled doors.
- ♦ A screw gun, pre-drill kit or automatic screwfeeder can also be added.

CAPABILITIES

	HINGE JAMB ROUTER	DOOR AND JAMB ROUTER
Width:	3 1/2" to 10 1/2"	3 1/2" to 10 1/2"
Height:	Up to 8'	Up to 8'
Thickness:	1/2" to 1 1/2"	1/2" to 1 1/2"
Butt Sizes:	3 1/2", 4", 4 1/2" & 5"	3 1/2", 4", 4 1/2" & 5"
Hinge Locations:	Unlimited	Unlimited
Butt Radius:	1/4" & 5/8"	1/4" & 5/8"
Door Width:	NA	Up to 3' (standard)
Door Height:	NA	Up to 8'
Door Thickness:	NA	Up to 2 1/4"

SPECIFICATIONS

	HINGE JAMB ROUTER	DOOR AND JAMB ROUTER
Machine Size:	10'L x 2'W	10'L x 2'W
Electrical Requirements:	120 V, Single Phase 15 AMP	120 V, Single Phase 15 AMP
Air Requirements:	1.5 CFM @ 100 PSI	1.5 CFM @ 90 PSI
Shipping Weight:	Approx. 500 lbs	Approx. 500 lbs

Door Stacker

The Diamond **Door Stacker** palletizes your doors for shipping or in-shop movement and ends unnecessary balancing, bending and repetitious lifting. The machine is engineered to reduce potential injury and fatigue while increasing productivity.

A completed interior or exterior door unit, with or without trim, is placed onto a pallet for vertical staging. A ratchet system holds the door in place until a full pallet is completed. With a flip of a switch the units are compressed to allow for bracing or banding.

The Diamond **Door Stacker** can be used as a free standing machine or it can be integrated with an interior or exterior door line or Stretch wrapping machine.

- Options:**
- ◆ Auto change height- 6'8", 7'0", 8'0"
 - ◆ Pneumatic Pallet Stop and Conveyor



Exterior Door Unit



Interior Door Unit



CAPABILITIES

- Width:** Stacker- Singles up to 4'
Double Stacker- Doubles up to 6'
- Height:** Up to 8'
- Doors:** All Types Interior or Exterior

SPECIFICATIONS

- Machine Size:** 4'L x 4'W x 7'6"H
- Air Requirements:** 1 CFM @ 80 lbs
- Shipping Weight:** Approx. 500 lbs

Weather Strip Machine



MACHINE FEATURES

- ◆ The Weather stripping Installation Machine automatically inserts all types of weather stripping (foam, magnetic and compression) into all kerfed jambs.
- ◆ Production rate up to 200 jambs per hour.
- ◆ New features include:
 - Safety Guard
 - Larger Motor
 - Reversible direction

CAPABILITIES

- Width of Jamb:** Up to 8'
- Height of Jamb:** Unlimited
- Type of Weatherstripping:** All Types
- Machine Capacity Rate:** Over 200 Jambs per hour

SPECIFICATIONS

- Machine Size:** 6' L x 2' W x 2' H
- Electrical Requirements:** 115 V, standard wall outlet
- Motor:** 1/4 HP
- Shipping Weight:** 250 lbs.

ROLLER TOP TILT TABLE

- ◆ Tilts up completed units for ease of handling to a door cart or rack.
- ◆ Adjustable to match the out feed height of any door line.
- ◆ Heavy Duty 42" rollers are standard. *(Custom widths are available)*
- ◆ Holsters and air connects can be added for air tools.
- ◆ Can be used as a packaging workstation.
- ◆ Custom Sizes Available.



**Shown with optional soft face rollers*

FLAT TOP TILT TABLE

- ◆ Solid 6' flat top working surface.
- ◆ Entire surface tilts for ease of loading and unloading.
- ◆ Can be used for single doors, double doors or window units.
- ◆ Holsters and air connects can be added for air tools.
- ◆ Custom sizes available.



CLAMPING ASSEMBLY TABLES

- ◆ Clamps keep door units square during assembly
- ◆ Holsters and air connects can be added for air tools.
- ◆ Will handle up to 8' tall door units.
- ◆ Available in 3', 6', 9', 12' and 16' widths.



CLAMPING/TILTING ASSEMBLY TABLES

- ◆ Tilt up heavy interior or exterior door units.
- ◆ Clamps keep door units square during assembly.
- ◆ Holsters and air connects can be added for air tools.
- ◆ Will handle up to 8' tall door units.
- ◆ Available in 3', 6', 9', 12' and 16' widths.
- ◆ Optional sidelite and transom extensions available.



PVC ROLLER TABLE

Our heavy duty PVC roller tables are non-marring to doors and jambs. They work with the Full House line of machines and we can match the height of any existing door lines. Convenient storage can be added underneath on a plywood deck. Holsters and air connects can be added.



Width (in.)	Height (ft.)	Model	Shpg. Wt.	\$ Each
42	8	FHRT428	500.0	1,200.00
42	10	FHRT4210	625.0	1,500.00
52	8	FHRT528	625.0	1,600.00
52	10	FHRT5210	775.0	2,000.00

Ask about custom sizes.

Additional option: Custom soft derometer rollers for pre-finished doors.

CONVEYERS

FLOOR CONVEYER

This heavy duty floor conveyer works with all Full House door loaders. 1.9" Galvanized rollers. Butt couplings allow sections to be bolted together. Roller Capacity 210 lbs.

- ♦ Frame Width 16 in. — Between Rail Width 13 in.

ROLLER TABLE

This heavy duty roller table works with all Full House door lines. 1.9" Galvanized rollers. Butt couplings allow sections to be bolted together. Needs stand sold separately. Roller Capacity 210 lbs. ♦ Frame Width 42 in. — Between Rail Width 39 in.

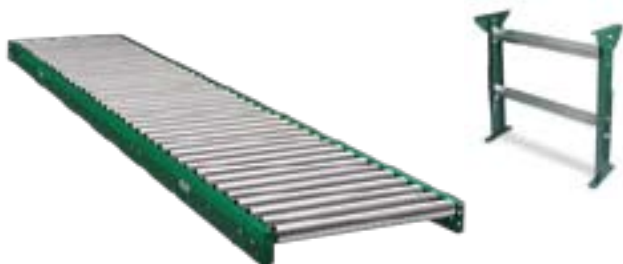

Length (ft.)	Roller Spacing (in.)	Frame Capacity (lbs.)	Model	Shpg. Wt.	\$ Each
Floor Conveyor - Fame width 16 in.					
5	3	620	FH00100	83.0	140.00
5	6	620	FH00101	60.0	95.00
10	3	135	FH00102	159.0	280.00
10	6	135	FH00103	113.0	190.00
Conveyor - Frame width 42 in.					
5	3	620	FH00104	173.0	232.00
5	6	620	FH00105	112.0	154.00
10	3	235	FH00106	328.0	464.00
10	6	135	FH00107	207.0	308.00

STATIONARY FLOOR SUPPORTS

Welded Frame Assembly. Adjustable Feet. Adjustable Pivot Plate.

Height Adj. to Top of Roller	Model	Shpg. Wt.	\$ Each
27 ³ / ₈ - 39 ³ / ₈	FH00150	22.5	52.00
37 ³ / ₈ - 49 ³ / ₈	FH00151	24.0	77.00

ADJUSTABLE ROLLING STAND

- ♦ Number of rollers: 9
- ♦ Roller size: 19-1/2" long x 2" diameter
- ♦ Minimum stand length: 19-1/2"
- ♦ Maximum stand length: 54"
- ♦ Minimum stand height: 24-1/2"
- ♦ Maximum stand height: 38"
- ♦ Casters: polyurethane, 4-1/4" diameter, two-way locking swivel
- ♦ Legs: Independently adjustable
- ♦ Multiple Stands can be connected for unlimited rolling capacity
- ♦ 300 lb. capacity



Desc.	Model	Shpg. Wt.	\$ Each
Adj. Rolling Stand	FH00170	88.0	195.00

ROLLER WORK STANDS

Steel stands have nonskid rubber feet and fold flat for storage. The WM5 roller assembly is polished and rust-resistant. No assembly required. WM3 features twelve 3/4" all-directional steel ball bearing rollers. Some assembly required.



Roller Width-Dia. (in.)	Max Height (in.)	Min. Height (in.)	Hold Capacity (lbs.)	Model	Shpg. Wt.	\$ Each
11 1/2 - 2	43 1/2	27 1/2	250	FH00171	12.4	31.85
18	45	24	250	FH00172	11.4	32.30

BALL ROLLER KIT - SET OF 6

- ♦ 360° rotation
- ♦ 1" (25mm) hardened ball bearing
- ♦ Great for flat surfaces like wood & plastic
- ♦ Mounting screws included



Desc.	Model	Shpg. Wt.	\$ Each
Ball Roller Kit	FH00173	3.0	21.50

10" LEFT TILT CABINET TABLE SAWS



BASE IN PICTURE IS NOT INCLUDED

Specifications

Motor:	3 HP, 18A, single-phase, 220V (FH01001) 5HP, 28A, single-phase, 220V (FH01005)
Drive:	Triple belt
Table size:	40-1/8" x 27" with wings (included)
Table:	Precision ground cast iron with T-Slots
Arbor:	5/8" (can accept up to 13/16" Dado set as well)
Table saw inserts:	Two included (Standard and Dado)
Miter gauge:	Heavy-duty cast-iron includes patented adjustable miter bar
Switch:	Heavy-duty magnetic
Maximum blade height:	3"
Ripping capacity with standard rails:	26" (Optional long rails available)
Handwheels:	Extra large cast iron
Fence:	Classic
Power cord size:	10' x 12 Gauge
Guard:	Clear plastic

- ♦ Sealed ball bearing construction
- ♦ Motor cover and dust port included
- ♦ Powder coated paint

Description	HP	Model	Shpg. Wt.	\$ Each
10" LT Table Saw	3	FH01001	474.0	1,225.00
10" LT Table Saw	5	FH01005	478.0	1,235.00
Heavy-Duty Mobile Base	–	FH01180	38.0	50.00
Zero Clearance Insert for Cabinet Saws	–	FH01181	1.0	25.00

10" LEFT TILT CABINET TABLE SAW W/ EXTENSION KITS

CLASSIC FENCE

- ♦ Wide right angle design
- ♦ Single locking cam action lever
- ♦ Fine-lined magnified cursor can be mounted on either side of the fence

ORIGINAL HEAVY-DUTY FENCE

- ♦ Locks on both ends
- ♦ Moves on ball bearing guides
- ♦ T-Slotted for attaching fixtures
- ♦ Fine-positioning knobs on both sides for left or right-handed use.



FH01003

Description	Classic Fence	Original Fence	27" x 44" Ext. Table	7" Rails	Ripping Capacity	Mobile Base w/Ext.	40T Blade	Model	Shpg. Wt.	\$ Each
3 HP, 10" Table Saw	X		X	X	52"			FH01002	580.0	1,455.00
3 HP, 10" Table Saw		X	X	X	50"			FH01003	591.0	1,335.00
3 HP, 10" Table Saw	X			X	52"			FH01004	560.0	1,265.00
5 HP, 10" Table Saw	X		X	X	52"			FH01011	590.0	1,405.00
5 HP, 10" Table Saw	X		X	X	52"	X	X	FH01006	652.0	1,475.00
5 HP, 10" Table Saw		X	X	X	50"	X	X	FH01007	600.0	1,395.00
5 HP, 10" Table Saw	X			X	52"			FH01008	560.0	1,285.00

12" TABLE SAWS WITH RIVING KNIFE

This 12" table saw is loaded with features you'd expect to find only on machines priced much higher. With its 5 HP, 220V, single-phase motor, the **FH01009** will easily rip large plywood and composition panels all day long. Includes a quick release riving knife, splitter, blade guard, digital bevel angle readout, rail-mounted switch, precision-ground cast iron table, cast iron trunnions and a 12" blade.

- ◆ Precision-ground cast iron table
- ◆ Cast iron trunnions
- ◆ 3/8" x 3/4" T-slots & miter gauge
- ◆ 4" dust port
- ◆ Power transfer: V-belt
- ◆ Steel cabinet
- ◆ Hinged motor cover
- ◆ Right hand extension table
- ◆ Magnetic switch with thermal overload protection & large off paddle for safety
- ◆ Quick release steel splitter
- ◆ Digital readout for bevel angle
- ◆ Includes 12" blade



Specifications

Motor:	5 HP, 220V, single-phase
Amps:	22.4
Blade tilt:	Left
Table height from floor:	35-3/4"
Table size (W1761):	30-3/4" x 48-3/4"
Arbor speed:	3,600 RPM
Arbor size:	1"
Maximum dado width:	1"
Maximum depth of cut @ 90°:	4"
Maximum depth of cut @ 45°:	2-3/4"
Maximum rip capacity:	52"

Description	HP	Model	Shpg. Wt.	\$ Each
12" Table Saw w/Cast Iron Wings	5	FH01009	901.0	2,495.00
12" Table Saw w/Ext. Table	7½	FH01010	901.0	2,495.00
Heavy-Duty Mobile Base	–	FH01180	38.0	50.00
Zero Clearance Insert for Cabinet Saws	–	FH01181	1.0	25.00

15" PLANER W/ CAST IRON WINGS & MOBILE BASE

Equipped with pedestal mounted thermal overload safety switch, cast iron extension wings, an impressive 15" x 8" capacity and a built-in mobile base, you'll find everything you ever wanted in a 15" planer including an affordable price.



Specifications

Motor:	3 HP, 220V, single-phase
Maximum cutting width:	15"
Maximum cutting height:	8"
Minimum stock thickness:	3/16"
Minimum stock length:	8"
Maximum cutting depth:	1/8"
Feed rate:	16 FPM & 30 FPM
Cutterhead diameter:	3"
Knives:	3 (HSS)
Cutterhead speed:	5,000 RPM
Power feed rollers:	solid serrated steel
Table size:	15" x 20"

Description	Model	Shpg. Wt.	\$ Each
15" Planer w/ Mobile Base	FH01050	675.0	1,075.00
Replacement 15" Planer Knives (3)	FH01051	116.0	25.00

8" JOINTER

This 8" Jointer is high on everyone's wish list and offers rugged cast iron construction, large capacity for precision edges on long boards, magnetic switch, 3-knife cutterhead and durable center-mounted, fully adjustable 90° to ±45° tilting fence.



Specifications

Motor:	2 HP, 220V, single-phase, TEFC capacitor start induction, 3,450 RPM
Table size:	9-1/4" x 70", infeed length 34-1/4"
Overall length:	70"
Overall depth:	27-1/2"
Height to table:	31-1/4"
Foot print:	23-1/2" x 19"
Cutterhead diameter:	3"
Knives:	3 - 8" x 1" x 1/8"
Rabbeting capacity:	1/2"
Max. width of cut:	8"
Cutterhead speed:	5,500 RPM
Cuts per minute:	16,500
Fence:	39-9/16" x 4-7/8"
Fence tilt:	45° L, 90°, 45° R

Description	Model	Shpg. Wt.	\$ Each
8" Jointer	FH01100	495.0	1,020.00
Heavy-Duty Mobile Base	FH01180	38.0	50.00

14" BANDSAW

We took the most popular bandsaw size and added many features only found on much larger and more expensive machines. Features such as extruded aluminum fence and rails, quick release blade tension, miter gauge, upper and lower ball bearing blade guides, enclosed cabinet stand, hinged wheel covers, 4" dust port and powerful 1 HP motor are all standard. And, with its cast iron frame and table, this bandsaw will be a reliable shop fixture for many years to come.



Specifications

Motor: 1 HP, TEFC, 110V/220V, single-phase, 1,725 RPM
 Amps: 14 @ 110V, 7 @ 220V
 Blade size: 93-1/2" (1/8" to 3/4" wide)
 Blade size w/ extension block: 105"
 Table size: 14" x 14" x 1-1/2"
 Table height above floor: 43"
 Cutting capacity (throat): 13-1/2"
 Maximum cutting height: 6"
 Table tilt: 45° right, 10° left
 Blade speeds: 1,500 & 3,200 FPM
 Frame construction: Cast iron
 Footprint: 18"W x 15-1/2"D

- ◆ Precision ground cast iron table
- ◆ Cast iron wheels
- ◆ Deluxe extruded aluminum fence
- ◆ Ball bearing blade guides

Description	Model	Shpg. Wt.	\$ Each
14" Bandsaw	FH01150	275.0	515.00
6" Extension Block Kit (Use 105" blade)	FH01152	15.0	55.00
Mini Mobile Base	FH01182	20.0	45.00

17" BANDSAW

With 12" of cutting height and a 16-1/4" throat capacity, this Bandsaw is built to handle large cutting chores. Its 2 HP motor has plenty of power to push 1" blades for resawing. Thoughtful engineering makes this saw a pleasure to use and includes convenient controls, a pair of dust ports for efficient dust collection, ball bearing blade guides and easy-to-read tension scale. Standard features include fence, miter gauge and 1/2" blade.



Specifications

Motor: 2 HP, single-phase, 60 Hz, 220V, TEFC capacitor start induction
 Amps: 12
 Blade size: 132" long
 Blade sizes range: 1/8" - 1" wide
 Table size: 23-3/4" x 17-1/2" x 1-1/2" thick
 Table height above floor: 37-1/2"
 Cutting capacity (throat): 16-1/8"
 Maximum cutting height: 12"
 Table tilt: 10° left, 45° right
 Blade speeds: 1,600, 3,300 FPM
 Footprint: 27"W x 17-3/4"D

- ◆ Precision ground cast iron table
- ◆ Cast iron wheels
- ◆ Deluxe extruded aluminum rip fence
- ◆ Ball bearing blade guides
- ◆ Sealed and permanently lubricated ball bearings

Description	Model	Shpg. Wt.	\$ Each
17" Bandsaw	FH01151	454.0	1,025.00
Heavy-Duty Mobile Base	FH01180	38.0	50.00

Full House carries the full line of Shop Fox Machinery call for full product listing.

SHAPER

We designed this Shaper for maximum performance at an affordable cost, with 25% more power and 40% more weight than other shapers in its price range.



Shown with Heavy-Duty Mobile Base FH01180 (Not Included)

Specifications

Motor:	2 HP, 110/220V, Single-phase
Spindles:	1/2" and 3/4" (Included)
Spindle travel:	3"
Table size:	24" wide x 21" deep
Stand:	Cabinet style, powder coated paint
Power cord size:	10' x 14 gauge
Spindle speeds:	7,000 & 10,000 RPM
Spindle openings:	1-1/4", 3-1/2" & 5"
Dust port size:	3"
Footprint:	18-1/2" x 18-1/2"

Description	Model	Shpg. Wt.	\$ Each
2 HP Shaper	FH01170	293.0	825.00
Extension Table (23" x 40")	FH01171	16.0	120.00
Router Bit Spindle (Fits 1/4" & 1/2" Bits)	FH01172	1.0	35.00
Heavy-Duty Mobile Base	FH01180	38.0	50.00

6" X 80" EDGE SANDER

6" X 80" ALUMINUM OXIDE SANDING BELTS - 2PK.

Grit	Model	Shpg. Wt.	\$ Each
60	FH01201	2.0	12.00
80	FH01202	2.0	12.00
100	FH01203	2.0	12.00
120	FH01204	2.0	12.00
150	FH01205	2.0	12.00
180	FH01206	2.0	12.00
220	FH01207	2.0	12.00



You will appreciate the balance this Edge Sander strikes between industrial-like quality and a compact size that won't hog precious shop space. Solid features like the graphite coated cast iron platen, the precision ground cast iron tables, and the super stable powder coated stand will make this edge sander a lifetime investment.

Specifications

Motor size:	1-1/2 HP, Single-Phase, 110/220V, Prewired 220V, 1,725 RPM
Table size:	22" x 10-1/2"
Table height:	36-3/4" x 41-3/4"
Table travel:	5"
Belt size:	6" x 80"
Belt speed:	1,800 FPM
Footprint:	48"W x 22"D
Platen size:	6-3/4" x 29-3/4", graphite coated
Drum Diameter:	35/16"

Description	Model	Shpg. Wt.	\$ Each
6" x 80" Edge Sander	FH01200	260.0	735.00

15" WIDE BELT SANDER

This Wide-Belt Sander with open end will sand flat panels up to 30" wide in half the footprint of other wide-belt sanders with the same capacity. Features include independent motor controls, pneumatic belt tensioning, tracking and oscillation, amp/load meter, safety shut off bar, pull out support bar, built-in regulator/filter, 5" dust port and emergency disc brake.

OTHER SIZES AVAILABLE

16" X 48" ALUMINUM OXIDE BELTS

Grit	Model	Shpg. Wt.	\$ Each
60	FH01212	1.0	25.00
80	FH01213	1.0	24.00
100	FH01214	1.0	24.00
120	FH01215	1.0	19.00
150	FH01216	1.0	24.00



Specifications

Sanding motor:	5 HP, 220V, 32 Amp, Single-phase
Sanding motor speed:	1,725 RPM
Feed motor:	1/4 HP
Belt speed:	2,050 FPM
Feed rates:	13 and 16 FPM
Maximum sanding width:	15" x 2
Maximum stock thickness:	5-1/2"
Minimum stock length:	12"
Minimum stock thickness:	1/8"
Belt size:	16" x 48"
Required air pressure:	75 PSI @ 2 CFM for belt tracking
Dust port:	5"
Footprint:	29" wide x 27-1/4" deep
Height with dust port:	62"

Description	Model	Shpg. Wt.	\$ Each
15" Wide Belt Sander	FH01211		4,265.00

*Larger width sanders also available

H-SERIES PANEL SAWS

The H-Series offers full-sized vertical panel saw productivity in economical machines. H-Series saws cut within 1/32" on a wide variety of panel materials up to 1 3/4" thick, and are available in three standard crosscutting widths, 50", 64" and 73". H-Series saws are used in all kinds of panel processing applications.

Standard Equipment

- 3 Hp, 15 amp industrial duty saw motor.
- Zinc plated 1 3/4" steel guide tubes.
- 4 Nylatron roller bearing systems.
- Adjustable vertical and horizontal rulers.
- Thin material pressure guard.
- Spring loaded counter balance system.
- Injection-molded plastic material rollers.
- Quick change from vertical to horizontal cutting.
- 1 year parts warranty.
- Lifetime frame warranty.

Specifications

Max. Crosscut:	(H4) 50"/1270mm, (H5) 64"/1625mm, (H6) 73"/1850mm
Max. Rip Cut:	Unlimited
Max. Cut Thickness:	1 3/4"/45mm
Cut Accuracy, Straight and Square:	1/32"/0,8mm
Saw Blade Diameter:	8"/200mm
Motor:	120V, 15amp (220V available)
Frame Length:	120"/3050mm



Crosscut Width (in.)	Model	Shpg. Wt.	\$ Each
50	FH01500	244.0	2,199.00
54	FH01501	298.0	2,399.00
73	FH01502	395.0	2,699.00

6400 PANEL SAW

This vertical panel saw utilizes heavy-duty worm gear driven saw motors for production applications. The additional steel supports in the frame, worm driven motor, double guide tube bearings and machined aluminum material rollers result in a heavier duty machine with a guaranteed cutting accuracy of 1/64" straight and square. Cuts panels up to 64" wide.

Standard Equipment

- 3 Hp worm driven heavy duty saw motor.
- 10 ft. Welded steel frame.
- Chrome plated 1 3/4" guide tubes.
- 8 Nylatron roller bearing systems.
- Adjustable vertical and horizontal rulers.
- Thin material pressure guard.
- Enclosed counterweight system.
- Solid aluminum material rollers.
- Quick change from vertical to horizontal cutting.
- 1 year parts warranty.
- Lifetime frame warranty.

Specifications

Max. Crosscut:	64"/1625mm
Max. Rip Cut:	Unlimited
Max. Cut Thickness:	1 3/4"/45mm
Cut Accuracy, Straight & Square:	1/64"/0,4mm
Saw Blade Diameter:	8"/200mm
Motor:	120V, 13amp (220V available)
Frame Length:	120"/3050mm
Shipping Weight	598 lbs./ 271 kg

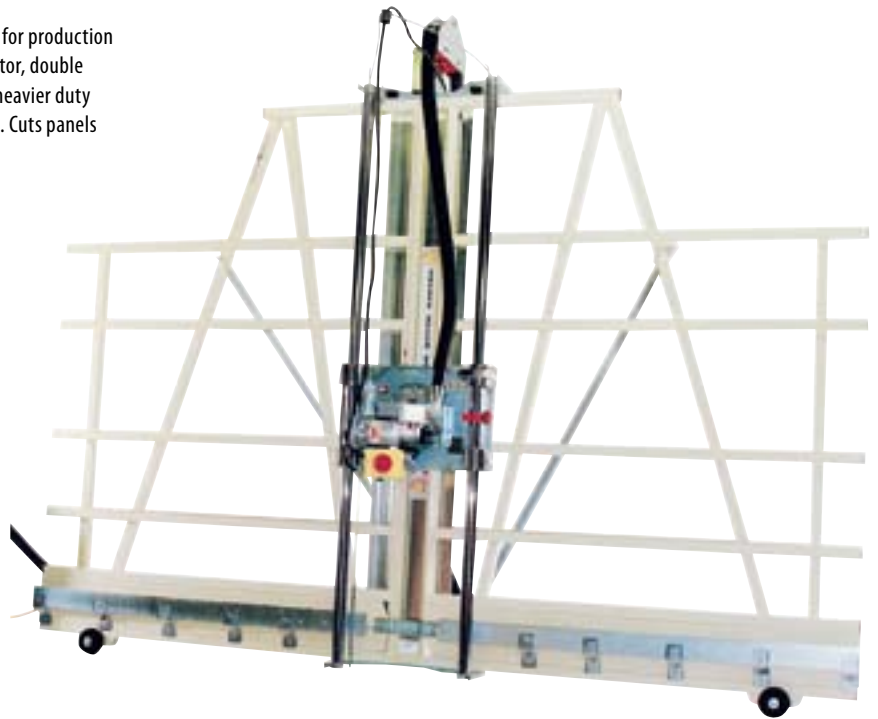

Crosscut Width (in.)	Model	Shpg. Wt.	\$ Each
64	FH01503	598.0	3,699.00

LOCK INSTALLATION KIT, CYLINDRICAL LOCK BORING JIG

The quick, easy way to install cylindrical locks. Drills all holes in one set-up. Adjustable jig locates for 2 3/8 or 2 3/4" backset in seconds. Includes strike locator for accurate placement of jamb mortise. Standard Equipment: Lock boring jig, 1" boring bit, full-up strike mortiser, latch mortiser, maximum security mortiser, strike locator, quick-change drill adapter and storage case.



Door Thickness (in.)	Model	Shpg. Wt.	\$ Each
1 5/16 to 2 1/8	FHPC511	6.7	235.00

DOOR LOCK INSTALLATION KIT

Lock guide features unique clamping system that does not require top or screws. 1 and 2 1/8" hole saws (included) are for wood and metal doors from 1 3/8 to 1 3/4" thick. Guides are built for over 100 installations and work with 2 3/8 and 2 3/4" back sets. Kit includes mandrel, adapter, washer, pilot drill, and guide all in a convenient plastic case.



Description	Max Cutting Depth (in.)	Arbor Hole (in.)	Thread Size (in.)	Model	Shpg. Wt.	\$ Each
7-Piece Hole Saw Kit	1 1/2	3/8	1/2-20 & 5/8-18	FHD1804	1.6	29.30

HEAVY DUTY LOCK MORTISER

Accurate cutting of mortises for box locks. Cuts mortises up to 7" long, 1 1/4" wide, 4 3/4" deep. Automatically centers cutter on door edge. Adjustable height rod for repetitive mortise cuts. Mounts to door in seconds. 10 Amps, AC only.



Amps	HP	RPM	Includes	Model	Shpg. Wt.	\$ Each
10	1 1/2	23,000	Mortising Machine, Height Rod Assembly, Wrench, Allen Wrench.	FHPC513	35.0	1,195.00

HEAVY-DUTY LOCK MORTISER TEMPLAT

Used to quickly rout lock faces on door after the mortise for the box lock itself has been completed. Automatically self-centering and self-beveling. Standard Equipment: Templet, Templet Guide and operating manual.



Desc.	Includes	Model	Shpg. Wt.	\$ Each
Lock Face Templet	Templet, Templet Guide and operating manual.	FHPC517	3.0	265.00

HINGE BUTT TEMPLAT KIT

Includes hinge butt templet, mortising bit, templet guide, lock nut, carrying case & operating manual. Will work with 6'6", 6'8" and 7' Jamb & Doors and 3" to 6" hinges.



Desc.	Model	Shpg. Wt.	\$ Each
Kit	FH59381	24.0	275.00

DOOR HINGE TEMPLAT

For mortising 3", 3 1/2", 4" square. 5/8" radius and 4 1/2" square hinges on doors and jambs. Includes FH43671 mortising bit.



Desc.	Model	Shpg. Wt.	\$ Each
Door Hinge Templet	FH59370	3.0	34.00

STRIKE & LATCH TEMPLAT

Strike & latch plate templet for lock mortising. Strike Plates: 1 1/8" x 2 3/4", 1 1/2" x 2 1/4", 1 1/2" x 2 3/4" Latch Plates: 1" x 2 1/4", 1 1/8" x 2 1/4", 1 1/8" x 2 3/4" Includes FH43671 mortising bit.



Desc.	Model	Shpg. Wt.	\$ Each
Strike & Latch Templet	FH59375	1.0	40.00

FLUSHBOLT TEMPLAT

Create flushbolts accurately and quickly. No longer will you have damaged doors from improper routing. This portable fixture is ideal for shop and job site. For Interior and Exterior doors. For use on standard 3/4" x 6" hardware only and with most standard T-Astragals. Door Sizes (in.): 1 3/8 - 1 3/4 Hardware Size (in.): 3/4 x 6 Includes: Template, Router bit and Template Guide



Desc.	Model	Shpg. Wt.	\$ Each
Flushbolt Templet	FHFB100	10.0	439.00

DELUXE BORE MASTER KIT



Professional quality and most complete lock installation kit for cylindrical locksets.

This kit is supplied with our best Templaco basic door fixture that will adjust from 2-3/8" to 2-3/4" backset positions and for doors from as thin as 1" to 2-1/2" thick.

Kit includes: HSS or carbide spur bits for boring both edge-bore and cross-bore, sizes are 1", 1-1/2" and 2-1/8". Also included are two complete lock and strike router template kits, Stock Number FH02505 & FH02506 which will provide for the mortising of most all of the popular lockset latches and strikes using your router. To complete the kit we include a 3/8" hex drive quick-release drill adapter to chuck the bits into your drill motor, a 1-1/2" reducer ring to use with the 1-1/2" spur bit, aluminum center marker with a steel point and a spring loaded corner chisel for squaring out the corners on both locksets and hinges. This complete kit is enclosed in a rugged red plastic case with strong latches.



BITS FOR BORE MASTER

Description	Model	Shpg. Wt.	\$ Each
QUICK-RELEASE ADAPTER FOR HEX SHANKS			
3/8" Shank	FH02006	1.0	22.00
HSS SPUR BITS			
1"	FH02007	1.0	38.00
2 1/8"	FH02008	1.0	38.00
7/8"	FH02009	1.0	38.00
CARBIDE-TIPPED SPUR BITS			
1"	FH02012	1.0	74.00
1 1/2"	FH02013	1.0	74.00
2 1/8"	FH02014	1.0	74.00
CENTER POINT FOR SPUR BITS			
1" and smaller	FH02011	1.0	4.50
1" and larger	FH02023	1.0	4.50
SPADE BITS			
1"	FH02010	1.0	38.00
REPLACEMENT BIT TIP			
1"	FH02015	1.0	8.00



COMMON REPLACEMENT PARTS FOR BORE MASTER

Description	Model	Shpg. Wt.	\$ Each
Latch	FH02016	1.0	13.00
Strike, No Lip	FH02017	1.0	14.00
1/2" Bore Bushing, Bronze	FH02018	1.0	5.00

Description	Model	Shpg. Wt.	\$ Each
Deluxe Bore Master Kit w/Steel Spur Bits	FH02000	13.0	375.00
Deluxe Bore Master Kit w/2 Carbide Spur Bits	FH02001	13.0	447.00
Deluxe Bore Master Kit w/3 Carbide Spur Bits	FH02002	13.0	483.00

BORE MASTER JR. KIT



Kit includes: standard Templaco basic door fixture that will adjust from 2-3/8" to 2-3/4" backset positions and for doors from as thin as 1" to 2-1/2" thick, (for thicker doors up to 3 inches please contact us). Kit includes HSS or carbide spur bits for boring both edge-bore and cross-bore, sizes are 1", 1-1/2" and 2-1/8". Also included are two mortis markers to mark the outline of the latch plate on the door and the strike plate on the jamb for mortising with your chisel. To complete the kit we include a 3/8" hex drive quick-release drill adapter to chuck the bits into your drill motor, a 1-1/2" reducer ring to use with the 1-1/2" spur bit and an aluminum center marker with a steel point. This complete kit is enclosed in a rugged black plastic case.

Description	Model	Shpg. Wt.	\$ Each
Bore Master Jr. Kit w/Steel Spur Bits	FH02003	9.0	302.00
Bore Master Jr. Kit w/2 Carbide Spur Bits	FH02004	9.0	376.00
Bore Master Jr. Kit w/3 Carbide Spur Bits	FH02005	9.0	412.00

Call Full House for Bore Master replacement parts and accessories...

CLICK'S KWIK DRILL

- ◆ Portable gang drill used for drilling out pilot holes for door hinges.
- ◆ No more misaligned hinges.
- ◆ Produces perfectly positioned pilot holes.
- ◆ Can be used with any 3/8" drill motor.
- ◆ Custom designed for 3-1/2", 4", or 4-1/2" hinges. They can also be custom built for any application.



Description	Hinge Size (in)	Corner Type	Model	Shpg. Wt.	\$ Each
3 Screw Kwik Drill	3 1/2	5/8" Radius	FH02100	3.0	285.00
4 Screw Kwik Drill	4	Square	FH02101	3.0	285.00
4 Screw Kwik Drill	4 1/2	Square	FH02102	3.0	275.00

BASIC BORE MASTER

This is the workhorse of all Templaco Bore Master Kits.

Each fixture is made from solid aluminum stock and heat treated aluminum castings, then machined by computer guided machines to maintain accuracy. User replaceable 1-1/2" long by 1/2" inside diameter bronze bushings at both edge bore and cross bore positions maintain a perfect alignment for the boring bits. The perfected design is unique to the industry, as this clamp on boring fixture has the largest surface area contacting the door and the greatest holding power preventing the slightest movement on the door while in use.

- ◆ For use with Carbide Tipped Spur Bits
- ◆ **Fixture only**, boring bits are not included



Description	For Door Thickness (in)	Lock Back Spacing (in)	Made from	Model	Shpg. Wt.	\$ Each
Basic Bore Master	1- 2 1/2	2 3/8 - 2 3/4	Solid Aluminum Castings	FH02019	6.0	199.00

DOUBLE BORE MASTER

Dual Bore Master Jib with Magnetic Spur Bit Retention.

Four user replaceable bronze bushings guide the four spur bits and produce exact bores at 90° to each other on 5-1/2" centers. The double bore master has a fixed centerline of 5-1/2" (optional centers available) and will bore two latch bore and two cross bore holes with the same set up. Bore for deadbolts at the same time you bore for the lockset. Installed are two high power magnets at the 2-1/8" bore boss positions to retain the spur bits in the retracted position.

- ◆ For use with Carbide Tipped Spur Bits
- ◆ **Fixture only**, boring bits are not included

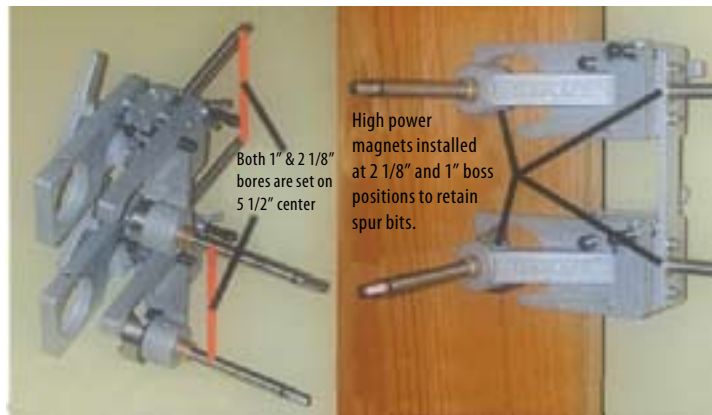

Both 1" & 2 1/8" bores are set on 5 1/2" center

High power magnets installed at 2 1/8" and 1" boss positions to retain spur bits.

Description	For Door Thickness (in)	Lock Back Spacing (in)	Made from	Model	Shpg. Wt.	\$ Each
Double Bore Master	1- 2 1/2	2 3/8 - 2 3/4	Solid Aluminum Castings	FH02020	9.0	515.00

REPLACEMENT PARTS FOR KWIK DRILL

Description	Model	Shpg. Wt.	\$ Each
1/8" Replacement Bits for CST35	FH02103	3.0	4.75
Base Plate/square corners for CST45	FH02104	3.0	33.00
11/64" Replacement Bits	FH02105	3.0	4.75

DOOR LOCK DRILL SET

Make your own wood doors and place the knobs wherever you want them with this handy two-piece high quality carbon tool steel set. This kit includes the bits necessary for knob and lock installation: a 7/8" screw point auger bit and a 2-1/8" saw-toothed forstner bit.



Desc.	Model	Shpg. Wt.	\$ Each
Door Lock Drill Set	FH02106	1.0	22.00

LATCH, STRIKE PLATE & HINGE TEMPLATES

These templates create perfect mortises on wood doors & jambs. Templates nail into door edge or jamb. All templates are designed to be used with a 1/2" mortising bit (FH43437) and a 5/8" outside diameter router template guide (FH02022).



FH02308

STRIKE PLATE MORTISING TEMPLATES

Strike Plate Size	Model	\$ Each
1" x 3"	FH02300	34.50
1" x 4-1/2"	FH02301	34.50
1" x 2 1/4" Full Lip	FH02309	30.00
1" x 2 1/4" deadbolt	FH02302	30.00
ball catch 2 1/8" x Full Lip	FH02303	34.50
1 1/8" x 2 3/4" (T)	FH02310	30.00
Emtek strike, oversize (2 1/4" + .028")	FH02304	42.00
1 1/4" x 3 5/8"	FH02311	30.00
1 1/4" x 4 7/8" ASA (T)	FH02312	30.00
1 1/16" x 5" (T-T)	FH02305	39.50
1" x 3 5/8" (T)	FH02313	34.50
1" x 4" (T)	FH02306	34.50
Dust box, latch bolt strike 7/8" x 1"	FH02307	34.50
Multi-strike template, 4 pockets	FH02308	49.00

Shpg. Wt. 1.0



FH02202

HINGE MORTISING TEMPLATES

Plate Size	Model	\$ Each
3" Hinge	FH02200	20.70
3 1/2" Hinge, 1/4" Radius	FH02201	20.70
4" Hinge, 1/4" Radius	FH02203	20.70
4 1/2" Hinge, 1/4" Radius	FH02205	20.70
5" Hinge, w/ABS, 1/4" Radius	FH02206	25.70
KF 3 1/2" Hinge, 5/8" Radius	FH02202	20.70
KF 4" Hinge, 5/8" Radius	FH02204	20.70
Soss Hinge, models 208 thru 220	FH02207	31.00

Shpg. Wt. 1.0



FULL LENGTH HINGE TEMPLATES

Full Length Templates	Model	\$ Each
3 1/2" hinge, 3 hinges 6'8" door	FH02600	50.66
4" hinge, 3 hinges, 6'8" door	FH02601	50.66
4 1/2" hinge, 3 hinges, 6'8" door	FH02602	50.66
KF 3 1/2" hinge, 3 hinges 6'8" door, 5/8" R.	FH02603	50.66
KF 4" hinge, 3 hinges, 6'8" door, 5/8" R.	FH02604	50.66
3 1/2" hinge, 4 hinges, 6'8" door	FH02605	53.07
4" hinge, 4 hinges, 6'8" door	FH02606	53.07
4 1/2" hinge, 4 hinges, 6'8" door	FH02607	53.07
3 1/2" hinge, 3 hinges, 7'0" door	FH02608	51.92
4" hinge, 3 hinges, 7'0" door	FH02609	51.92
4 1/2" hinge, 3 hinges, 7'0" door	FH02610	51.92
3 1/2" hinge, 4 hinges, 7'0" door	FH02611	54.34
4" hinge, 4 hinges, 7'0" door	FH02612	54.34
8' 0" Templates hinge sizes 3" - 4 1/2", up to 5 hinges	FH02613	59.54
8' 0" Templates hinge size 5", w/ ABS, up to 5 hinges	FH02614	84.54
3 hinge over 8' 0" these are two piece templates	FH02615	69.25
4 hinge over 8' 0" these are two piece templates	FH02616	77.65
5 hinge over 8' 0" these are two piece templates	FH02617	88.15
Soss Hinge, 3 pocket, up to 8'0" doors, 96" template	FH02618	79.00
Soss Hinge, 4 pocket, up to 8'0" doors, 96" template	FH02619	89.00

REPLACEMENT PARTS

Description	Model	Shpg. Wt.	\$ Each
Replacement Nail Assembly	FH02021	1.0	9.90
Brass Router Template Guide & Nut-5/8" outside dia.	FH02022	1.0	7.50



LATCH FACE MORTISING TEMPLATES

Latch Face Size	Model	\$ Each
1" x 2 1/4"	FH02505	20.90
1 1/8" x 2 1/4"	FH02506	20.90
1 1/16" x 2 1/4"	FH02507	20.90
1" x 3 3/8" (16" LOA)	FH02500	23.10
1 1/8" x 4 1/4"	FH02508	20.90
1" x 5 3/4"	FH02509	20.90
1" x 6"	FH02501	30.00
1 1/4" x 8"	FH02510	20.90
1 1/16" x 4 1/2"	FH02502	22.00
1" x 8"	FH02511	22.00
1" x 2-1/8" (16" LOA)	FH02503	39.00
Multi-latch template, 3 pockets	FH02504	42.00

Shpg. Wt. 1.0

FLUSHBOLT STRIKE MORTISING TEMPLATES

Finished Rout Size	Model	\$ Each
3/4" x 6", Flat End	FH02400	24.00
1" x 6 3/4"	FH02407	24.00
3/4" x 6", Round End	FH02401	24.00
1 1/4" x 6 3/4"	FH02408	24.00
1" x 6 3/8"	FH02402	39.00
Automatic, 1" x 10" (36" LOA)	FH02403	41.50
Strike, 7/8" x 1 3/4"	FH02405	32.00
Strike, 15/16" x 2 1/4"	FH02406	32.00
Guide Plate, 1" x 2" (LOA 18")	FH02404	32.00

Shpg. Wt. 1.0

LOCK BITS

All bits have a 1/2" Shank unless noted • 6" OAL



REPLACEMENT PARTS

Part	Model	Shpg. Wt.	\$ Each
Center Drill	FHDK560	1.0	15.00
Set Screw	FHDK565	1.0	2.00



CARBIDE-TIPPED LOCK BORING BITS

Size (in.)	Model	WITH FLAT		WITHOUT FLAT		
		Shpg. Wt.	\$ Each	Model	Shpg. Wt.	\$ Each
1 5/8	FHLOC158	1.0	145.00			
2 1/8	FHLOC600	1.0	123.00	FHLOC610	1.0	120.00
2 1/8 w/3 Flats	FHLOC605	1.0	140.00			

CARBIDE-TIPPED ECONOMY DOOR BIT

Size (in.)	Model	WITH FLAT		WITHOUT FLAT		
		Shpg. Wt.	\$ Each	Model	Shpg. Wt.	\$ Each
2 1/8	FH6100F	1.0	89.00	FH6100	1.0	86.00

CARBIDE-TIPPED 3 WING DRILLS

Bore plastic Formica™ and tempered Masonite™ as well as abrasive materials for hard wood.

CAUTION: To be used in a drill press, milling machine or boring machine only.

Size (in.)	Model	WITH FLAT		WITHOUT FLAT		
		Shpg. Wt.	\$ Each	Model	Shpg. Wt.	\$ Each
812-CT 2 1/8	FHDR410F	1.0	165.00	FHDR410	1.0	160.00
812-CT 1 5/8	FHDR370F	1.0	137.00	FHDR370	1.0	132.00
812-CT 1 1/2	FHDR360F	1.0	140.00	FHDR360	1.0	135.00
812-CT 1	FHDR320F	1.0	112.00	FHDR320	1.0	107.00

CARBIDE-TIPPED DOOR KNOB 3 WING DRILL

This bit features carbide at a 30° angle—the result is clean cuts, while shavings peel away. • 5 3/4" OAL

CAUTION: To be used in a drill press, milling machine or boring machine only.

Size (in.)	Model	WITH FLAT		WITHOUT FLAT		
		Shpg. Wt.	\$ Each	Model	Shpg. Wt.	\$ Each
2 1/8 Plug-less	FHDK510	3.0	129.00	FHDK500	3.0	124.00

MULTI SPUR BITS

Multiple spurs bore clean holes without chipping or splintering the surface of the wood. Perfect for boring through veneers. Cutting edge is precision ground at an angle for fast boring. Lifts chips clearly up and out of the hole.

Size (in.)	Model	WITH FLAT		WITHOUT FLAT		
		Shpg. Wt.	\$ Each	Model	Shpg. Wt.	\$ Each
CARBIDE TIPPED						
149-CT 2 1/8"	FHMS411F	1.0	163.00	FHMS411	1.0	153.00
149-CT 2 1/8"	FHMS410F	1.0	125.00	FHMS410	1.0	115.00
149-CT 1 5/8"	FHMS370F	1.0	148.00	FHMS370	1.0	138.00
149-CT 1 1/2"	FHMS360F	1.0	143.00	FHMS360	1.0	133.00
149-CT 1"	FHMS321F	1.0	114.00	FHMS321	1.0	104.00
149-CT 15/16"	FHMS315F	1.0	117.00	FHMS315	1.0	107.00
HIGH SPEED STEEL						
149 2 1/8"	FHMSHS411F	1.0	73.00	FHMSHS411	1.0	63.00
149 1 5/8"	FHMSHS370F	1.0	58.00	FHMSHS370	1.0	48.00
149 1 1/2"	FHMSHS360F	1.0	51.00	FHMSHS360	1.0	41.00
149 1"	FHMSHS321F	1.0	43.00	FHMSHS321	1.0	33.00

LATCH BITS



CARBIDE-TIPPED LATCH BITS

Ideal for materials that can be tough on bits. Can be used in drilling hard woods, fiberglass, plastics, laminates, or chip core.

Size (in.)	Length (in.)	Model	Shpg. Wt.	\$ Each
7/8	6 1/4	FHLAT670	1.0	101.00
7/8 - 1 FLAT	6 1/4	FHLAT680	1.0	103.00
7/8 **	5 7/8	FHLAT690	1.0	115.00
15/16	6 1/4	FHLAT720	1.0	101.00
15/16 - 1 FLAT	6 1/4	FHLAT730	1.0	103.00
15/16 **	5 7/8	FHLAT740	1.0	115.00
1	6 1/4	FHLAT770	1.0	103.00
1 - 1 FLAT	6 1/4	FHLAT780	1.0	115.00
1**	5 7/8	FHLAT790	1.0	115.00
1 - 3 FLATS	6 1/4	FHLAT780-3	1.0	120.00
1 1/16 **	5 7/8	FHLAT820	1.0	123.00

**Threaded Shank



CARBIDE-TIPPED BRAD POINT TWIST BIT

No. 200-CT • For Latch Bore. Recommended for drive-in bolts.

Drill Dia. (in.)	Twist Length (in.)	Shank (in.)	OAL (in.)	Desc.	Model	Shpg. Wt.	\$ Each
1	4	1/2	6	No Flat	FHBPT1	1.0	140.00
1	4	7/16-14	5 13/16	Threaded	FHBPT1T	1.0	147.00
1	4	1/2	6	One Flat	FHBPT1F	1.0	143.00
1	4	1/2	6	Three Flats	FHBPT3F	1.0	156.00
15/16	3	1/2	5	One Flat	FH1920914	1.0	84.95
1	3	1/2	5	One Flat	FH19210	1.0	79.95

DOOR LITE BITS



STAGGER TOOTH BIT FOR WOOD

Stagger tooth has shear up and shear down profile to prevent tearing of the door skin. Carbide tipped

OAL (in.)	Cutting Edge (in.)	Dia. (in.)	Model	Shpg. Wt.	\$ Each
5 1/2	2 1/2	1/2	FH1203	1.0	20.00

FOR WOOD & FIBERGLASS DOORS

2-Flute / Straight / Carbide Tipped

For precision cut outs on wood and fiberglass doors and is equally suitable for use with a hand held router.

OAL (in.)	Cutting Edge (in.)	WITH FLAT			WITHOUT FLAT		
		Model	Shpg. Wt.	\$ Each	Model	Shpg. Wt.	\$ Each
5 1/2	2 1/2	FHDL1/2F	1.0	32.00	FHDL1/2	1.0	22.00

FOR METAL DOORS

Single Flute / Down-spiral

These sowncut bits were specially designed for making superior cuts and openings in metal-clad doors. Designed for use on special-purpose door lite machines. Recommended speed for optimum performance: 2000 - 25000 rpm.

5 1/2" OAL, 2 1/2" Cutting Edge, 1/2" Shank

Type	Model	WITH FLAT		WITHOUT FLAT		
		Shpg. Wt.	\$ Each	Model	Shpg. Wt.	\$ Each
HSS	FHDOOR-57	1.0	30.00	FHDOOR-53	1.0	27.00
Ti-Coated	FHDOOR-60T*	1.0	34.00	FHDOOR-53T	1.0	30.00
HSS	FHDOOR60*	1.0	30.00			

* Full Twist

CARBIDE-TIPPED ROUTER BITS



STRAIGHT MORTISE BITS 1/4 Shank Bits

Cutting Dia. (in.)	Cutting Length (in.)	OAL (in.)	Model	Shpg. Wt.	\$ Each
1/2	5/8	2	FH1300	1.0	12.00
5/8	3/4	2	FH1301	1.0	14.00
3/4	3/4	2	FH1302	1.0	15.00
1 1/4	3/4	2	FH1303	1.0	20.00

DOUBLE FLUTE SCREW ON

All Cutters fit 1/4"-28 threaded shank.

Cutting Dia. (in.)	Cutting Length (in.)	Shank Dia. (in.)	Thread Size	Model	Shpg. Wt.	\$ Each
1/2	9/16	1/4**	(one piece)	FH43437	1.0	15.50
5/8	9/16	1/4**	(one piece)	FH43440	1.0	17.50
5/8	17/32	*	1/4 - 28	FH43698	1.0	29.00
3/4	17/32	*	1/4 - 28	FH43703	1.0	30.50
13/16	17/32	*	1/4 - 28	FH43700	1.0	32.00
7/8	17/32	*	1/4 - 28	FH43701	1.0	30.50
1	17/32	*	1/4 - 28	FH43704	1.0	30.50
1-1/8	17/32	*	1/4 - 28	FH43699	1.0	32.50
1-1/4	17/32	*	1/4 - 28	FH43745	1.0	26.00

*Requires shank purchased separately (see below). **2-3/8" OAL

SHANKS FOR PORTER-CABLE SCREW ON MORTISE BITS

Size (in.)	OAL (in.)	Thread	Model	Shpg. Wt.	\$ Each
1/4	1 1/2	1/4 - 28	FH43736	1.0	9.00
1/2	2 1/16	1/4 - 28	FH43737	1.0	11.00
1/2	3 1/4	1/4 - 28	FHHA50A	1.0	12.00

SCREW ON MORTISE BITS

Cutting Dia. (in.)	Cutting Dia. (Decimal)	Cutting Length (in.)	OAL (in.)	Model	Shpg. Wt.	\$ Each
1/4 - 28 Thread						
1/2	.500	5/8	7/8	FH13500	1.0	15.00
5/8	.625	5/8	7/8	FH13625	1.0	15.00
3/4	.750	5/8	7/8	FH13750	1.0	15.50
13/16	.812	5/8	7/8	FH13812	1.0	15.50
7/8	.875	5/8	7/8	FH13875	1.0	15.50
1	1.000	1/2	1/2	FH131000	1.0	16.00
1 1/8	1.125	1/2	1/2	FH131125	1.0	16.00
1 1/4	1.250	1/2	1/2	FH131250	1.0	16.00
5/16 - 24 Thread						
1 1/4	1.250	5/8	5/8	FH131250-516	1.0	16.00

SHANKS FOR SCREW ON MORTISE BITS

Size (in.)	OAL (in.)	Thread	Model	Shpg. Wt.	\$ Each
1/4	1 3/4	1/4 - 28	FHMA-14	1.0	4.50
1/2	1 3/4	1/4 - 28	FHMA-12	1.0	4.50
1/4	1 3/4	5/16-24	FHMA-14-516	1.0	5.50
1/2	1 3/4	5/16-24	FHMA-12-516	1.0	5.50



CARBIDE-TIPPED ROUTER BITS

Manufacturing process provides extremely accurate, consistent and concentric bits.

CNC-centerless ground with 0.0005" tolerance. Automotive-type, semi-transparent, powder-coat finish. Pozi-Stop® shank automatically locates bit at correct height. Monster Carbide® withstands resharpening - 40% thicker than standard bits.

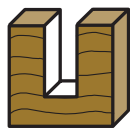

STRAIGHT

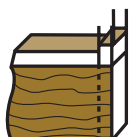

FLUSH TRIMMING

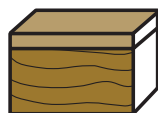

COMBINATION PANEL PILOT

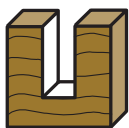

SOLID CARBIDE

CARBIDE-TIPPED ROUTER BIT SETS

Laminate Trim- 23° Bevel Trimmer with Bearings, Flush Trimmer with Bearing, 1/4" Straight Bit

Pattern/Trim- 1/2" Pattern with Top Mounted Bearing, 1/2" Laminate Flush Trim 2 Flute, 23° 3 Flute Bevel Trim, 1/4" Combination Panel Pilot Bit

All Purpose- 1/4" Double Flute Straight, 3/8" Double Flute Straight, 1/2" Double Flute Straight, 3/4" Double Flute Straight, and 5/8" Double Flute Straight Bit

Decorative- 3/8" Cove, 3/8" Roundover, 1/4" Roman Ogee, 45° Chamfer, 3/8" Rabbeting Bit, Replacement Bearings

Master Wood- 1/4" 2 Flute Straight, 3/8" 2 Flute Straight, 1/2" 2 Flute Straight, 3/8" V Groove, 1/2" Core Box, 45° Chamfer, 1/4" Roman Ogee, 3/8" Rabbeting, 3/8" Cove, 3/8" Corner Rounding Bit



Type	No. of Pieces	Model	Shpg. Wt.	\$ Each
Laminate Trim	3	FHRBS03	1.1	53.00
Pattern/Trim	4	FHRBSC4	1.3	63.00
All Purpose	5	FHRBS05	1.3	83.00
Decorative	6	FHRBS06	2.8	150.00
Master Wood	10	FHRBS10	3.0	215.00

Cutting Dia. (in.)	Flute Length (in.)	No. of Flutes	Cutting Length (in.)	Shank Dia. (in.)	Overall Length (in.)	Model	Shpg. Wt.	\$ Each
Straight Bits								
3/16	1/2	2	1/2	1/4	2	FH43051	0.1	21.00
1/4	3/4	2	3/4	1/4	2 1/8	FH43802	0.1	17.00
1/4	1	2	1	1/2	2 31/32	FH43207	0.1	19.00
1/4	1	2	1	1/4	2 1/2	FH43718	0.1	16.50
5/16	1	2	1	1/4	2 3/8	FH43300	0.1	16.50
3/8	1	2	1	1/4	2 1/2	FH43312	0.1	16.50
3/8	1	2	1	1/2	2 9/16	FH43719	0.1	19.00
1/2	1	2	1	1/4	2 1/2	FH43318	0.1	17.50
1/2	1 1/4	2	1 1/4	1/2	2 61/64	FH43058	0.2	18.50
1/2	2	2	2	1/2	4 13/64	FH43721	0.2	22.50
1/2	2 1/2	2	2 1/2	1/2	4 1/2	FH43118	0.3	34.50
1/2	1 1/2	2	1 1/2	1/2	2 7/8	FH43720	0.2	22.50
1/2	1	2	1	1/2	2 11/16	FH43057	0.2	19.00
5/8	1	2	1	1/4	2 1/4	FH43333	0.1	17.50
3/4	1	2	1	1/4	2 1/4	FH43052	0.1	19.50
3/4	1 1/4	2	1 1/4	1/2	3	FH43722	0.2	22.50
1	1 1/4	2	1 1/4	1/2	2 3/4	FH43063	0.3	26.50
Flush Trimming								
1/4	1	2	1	1/4	2 15/32	FH43286	0.1	27.00
3/8	1	2	1	1/4	2 7/8	FH43289	0.1	17.50
3/8	1/2	2	1/2	1/4	2 7/32	FH43276	0.1	18.50
1/2	1	2	1	1/4	3 31/64	FH43731	0.1	20.50
1/2	1/2	2	1/2	1/4	2 19/64	FH43252	0.1	18.50
1/2	1/2	2	1/2	1/4	2 19/64	FH43290	0.1	24.50
1/2	1	2	1	1/2	3 11/64	FH43730	0.2	20.50
1/4	1/4	2	1/4	1/4	1 1/2	FH43711	0.1	23.00
Combination Panel Pilot Bits								
1/4	3/4	1	3/4	1/4	2 3/4	FH43708	0.1	16.00
1/2	1 1/4	1	1 1/4	1/2	3 11/16	FH43064	1.0	18.50
3/8	1	2	1	1/4	3	FH43214	0.1	17.50
1/2	2	2	2	1/2	4 5/8	FH43215	0.2	28.50
Solid Carbide Bits								
1/8	1/2	2	1/2	1/4	1 1/2	FH43109	0.1	17.50
1/8	1/2	2	1/2	1/4	2	FH43820	0.1	23.00
1/4	1	2	1	1/4	2 1/2	FH43824	0.1	26.50
1/4	1/4	2	1/4	1/4	1 1/2	FH43711	0.1	23.00
1/4	3/8	1	3/8	1/4	2	FH43216	0.1	14.00
1/4	1/4	1	1/4	1/4	1 1/2	FH43512	0.1	11.50
1/8	1/4	1	1/4	1/4	1 1/2	FH43210	0.1	22.00
Key Hole Bit								
3/8	3/8	2	3/8	1/4	1 5/8	FH43319	0.1	38.50



GROOVING



ROUNDROVER

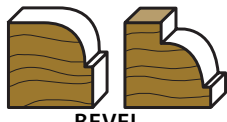

BEVEL

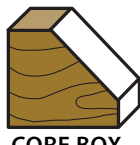

CORE BOX

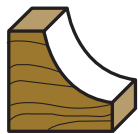

COVE

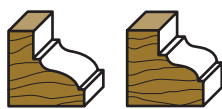

ROMAN OGEE

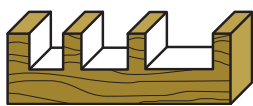

MORTISING

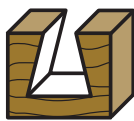

DOVETAIL

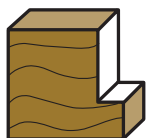

RABBET



TEMPLER CUT

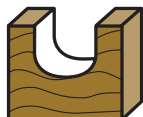

REEDING

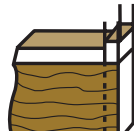

LAMINATE TRIM

TEMPLER GUIDES



ID	OD	Distance Past Base	Model	\$ Each
1 1/32"	1 1/4"	7/16"	FH42021	8.00
21/32"	3/4"	9/16"	FH42024	6.50
11/32"	7/16"	5/32"	FH42027	6.50
25/32"	1"	3/8"	FH42030	8.25
13/32"	1/2"	5/16"	FH42033	6.50
9/32"	3/8"	5/16"	FH42036	6.50
3/4"	59/64"	9/16"	FH42039	9.55
5/8"	54/64"	9/16"	FH42042	6.50
17/32"	5/8"	9/16"	FH42045	6.50
17/32"	5/8"	7/32"	FH42046	6.50
1 3/8"	1 35/64"	17/32"	FH42048	10.75
Lock Nut for all templet guides			FH42237	2.75

CARBIDE-TIPPED ROUTER BITS CONTINUED...

Cutting Dia. (in.)	Flute Length (in.)	No. of Flutes	Cutting Length (in.)	Shank Dia. (in.)	Overall Length (in.)	Model	Shpg. Wt.	\$ Each
Roundover Bits								
1 1/4	2 1/32	2	2 1/32	1/4	2 23/64	FH43405	0.2	33.50
1 1/2	3/4	2	3/4	1/4	2 7/16	FH43408	0.2	36.50
1	1/2	2	1/2	1/4	2 13/64	FH43402	0.2	32.00
3/4	23/64	2	23/64	1/4	2 1/64	FH43421	0.1	31.00
2 3/4	1 1/4	2	1 1/4	1/2	3 1/16	FH43428	0.7	117.00
1	1/2	2	1/2	1/2	2 13/64	FH43425	0.2	32.50
1 1/2	1/2	2	1/2	1/2	2 7/16	FH43091	0.3	39.50
1 1/4	21/32	2	21/32	1/2	2 23/64	FH43427	0.2	35.50
2	1	2	1	1/2	2 45/64	FH43092	0.4	58.00
Grooving Bits								
3/4	17/32	2	17/32	1/2	2 1/8	FH43077	0.2	31.50
3/8	5/16	2	5/16	1/4	1 3/4	FH43213	0.1	23.50
1/2	23/64	2	23/64	1/4	2	FH43725	0.1	25.50
Chamfer or Bevel Bits								
1 1/2	49/64	2	49/64	1/2	2 31/64	FH43190	0.3	33.00
1 1/2	49/64	2	49/64	1/4	2 31/64	FH43072	0.3	32.00
Core Box Bits								
1 1/4	21/32	2	21/32	1/4	29/32	FH43413	0.2	34.00
1	1/2	2	1/2	1/4	29/64	FH43410	0.2	31.00
1	1/4	2	1/4	1/4	2 29/64	FH43367	0.2	36.50
1 1/2	11/16	2	11/16	1/2	2 25/64	FH43174	0.3	54.50
Roman Ogee Bits								
1 1/2	3/4	2	3/4	1/2	2 15/32	FH43133	0.3	45.00
1 1/2	3/4	2	3/4	1/4	2 15/32	FH43127	0.3	40.00
Cove Bit								
1 1/4	5/8	2	5/8	1/4	2 29/64	FH43103	0.3	34.50
Hinge Mortising Bits								
1/2	9/16	2	9/16	1/4	2 5/16	FH43437	0.1	16.50
1 1/4	9/16	2	9/16	1/4	2 3/8	FH43442	0.2	27.00
Mortising Bit								
1/2	3/8	2	3/8	1/4	2 25/64	FH43671	0.1	36.50
Dovetail Bit								
1/2	33/64	2	33/64	1/4	2 17/32	FH43705	0.1	20.50
Templet Cut Bit								
1/2	1	2	1	1/4	2 63/64	FH43325	0.1	26.00
Rabbet Bit								
1 1/4	1/2	3	1/2	1/4	2 1/8	FH43082	0.2	32.00
Laminate Trim Bit								
15/16	15/32	2	15/32	1/4	2 15/64	FH43252	0.1	25.50
Reeding Bits								
1/2	3/8	2	3/8	1/4	1 5/8	FH43145	0.1	23.00
3/4	7/16	2	7/16	1/4	1 15/16	FH43147	0.1	27.00

CARBIDE-TIPPED ROUTER BITS



DOUBLE FLUTE STRAIGHT BITS

Number of Flutes	Cutting Dia. (in.)	Cutting Length (in.)	OAL	Model	Shpg. Wt.	\$ Each
1/4" Shank						
2	1/4	3/4	2 1/8	FH1013	1.0	11.00
2	1/4	1	2 1/2	FH1014	1.0	12.50
2	3/8	1	2 1/2	FH1022	1.0	12.50
2	1/2	1/4	2 1/4	FH1025A	1.0	17.00
2	1/2	1/2	2 1/4	FH1025B	1.0	19.00
2	1/2	2/4	2 1/4	FH1025C	1.0	15.00
2	1/2	1	2 3/4	FH1026	1.0	14.00
2	3/4	3/4	2 1/8	FH1030	1.0	18.00
1/2" Shank						
2	1/4	3/4	2 3/8	FH1058	1.0	15.00
2	3/8	1	2 5/8	FH1062	1.0	14.00
2	3/8	1 1/4	2 7/8	FH1063	1.0	15.00
2	7/16	1 1/4	2 7/8	FH1065L	1.0	16.00
2	1/2	1 1/4	2 7/8	FH1067	1.0	16.00
2	1/2	1 1/2	3 1/8	FH1069	1.0	17.50
2	5/8	1 1/4	3	FH1077	1.0	16.50
2	3/4	1 1/4	2 7/8	FH1085	1.0	17.00
2	1	1 1/2	3	FH1094	1.0	24.00
2	1/2	2	4 1/8	FH1072	1.0	23.00
2	1/2	2 1/2	4 3/8	FH1073	1.0	26.50

HOLE CUTTER

Engineered to Quickly Cut Holes through a Variety of Materials Including Stainless Steel, Steel Up to 10 Gauge, Copper, Brass, Aluminum, PVC, Fiberglass and Laminates



Hole Size	Shank Size	Model	Shpg. Wt.	\$ Each
2 1/8"	1/2"	FH03017	0.5	22.78

BIMETAL HOLE SAWS

Cuts through a 2 x 4-ft. in a single pass to 1 1/2" depth; no deep cutting hole saw needed. Bimetal construction with shock-resistant teeth that stay sharp longer. Positive rake for more aggressive action and chip clearance. Variable pitch tooth design and M3 cutting edge reduces vibrations and allows for smoother cuts. Cuts holes in wood, plastic, or any machinable metal including nail-embedded wood, plywood, pipe, and stainless steel.

Without Built-In Arbor



Saw Dia. (in.)	Model	Shpg. Wt.	\$ Each
5/8	FH03000	0.1	7.00
3/4	FH03001	0.1	7.00
7/8	FH03002	0/1	7.00
1	FH03003	0.2	7.00
1 1/4	FH03004	0.2	7.25
1 1/2	FH03005	0.2	7.65
1 5/8	FH03006	0.2	7.65
1 3/4	FH03007	0.1	9.75
2	FH03008	0.3	9.75
2 1/8	FH03009	0.3	11.95
2 1/4	FH03010	0.4	11.95
2 1/2	FH03011	0.4	11.95
3 1/8	FH03012	0.5	13.25

ARBOR WITH PILOT DRILL

For Use with Bimetal Hole Saws

FH03013 FH03014 FH03015 FH03016



Chuck Size (in.)	Shank Size (in.)	Fits Hole Saw Dia. (in.)	Thread Size (in.)	Brand	Model	Shpg. Wt.	\$ Each
1/4	1/4 Round	9/16 - 1 3/16	1/2 - 20	MORSE	FH03013	0.15	5.85
3/8	3/8 HEX	9/16 - 1 3/16	1/2 - 20	MORSE	FH03014	0.1	10.75
1/2	7/16 HEX	9/16 - 1 3/16	1/2 - 20	MORSE	FH03015	0.2	8.25
1/2	7/16 HEX	1 1/4 - 6	5/8 - 18	MORSE	FH03016	0.5	15.00

JOBBERS LENGTH DRILL SETS

15-PIECE SETS

Fractional sizes: 1/16 to 1/2 by 32nds.



29-PIECE SETS

Fractional sizes: 1/16 to 1/2 by 64ths.



# of Pieces	Type	Description	Model	Shpg. Wt.	\$ Each
15	High Speed Steel	General Purpose Grade, 118°—Black	FH03200	2.0	24.00
15	Cobalt	General Purpose, 135° Split Point—Bronze	FH03201	2.0	65.50
29	High Speed Steel	General Purpose Grade, 118°—Black	FH03202	3.1	44.75
29	Cobalt	General Purpose, 135° Split Point—Bronze	FH03203	3.5	108.20

JOBBERS LENGTH DRILLS - 118°

For use on general purpose, production, and maintenance drilling jobs. Split point models self-center and penetrate quickly, eliminating “walking.”



Size	Decimal Equivalent	Flute Length (in.)	Overall Length (in.)	Pkg. Qty.	Model	Shpg. Wt.	\$ Each
3/32	0.0938	1/4	2 1/4	12	FH03204	0.05	.62
7/64	0.1094	1 1/2	2 5/8	12	FH03205	0.05	.62
* 1/8	0.1250	1 5/8	2 3/4	12	FH03206	0.05	.68
9/64	0.1406	1 3/4	2 7/8	12	FH03207	0.05	.74
11/64	0.1719	2 1/8	3 1/4	12	FH03208	0.05	.85
3/16	0.1875	2 5/16	3 1/2	12	FH03209	0.05	.98

* Used on Marquise Pre-drill Units

SPADE BITS

Standard Length Flat

Fastest Speedbor with tri-flute design for faster drilling and chip ejection. Patented cutting spur leaves a smooth, clean hole. 1/4" hex shanks. Shanks grip firmly, won't slip. Patented micro-groove edge stays sharper longer. Cutting spurs for clean holes with minimal “break out.” Full screw tip for ease of use and pull through. Tapered flue for less binding and ease of use. Full length heat treat for more durability. Overall Length 6 in.



Bit Dia. (in.)	Model	Shpg. Wt.	\$ Each
1/4	FH03300	0.1	2.20
5/16	FH03301	0.1	2.20
3/8	FH03302	0.1	3.05
7/16	FH03303	0.1	2.65
1/2	FH03304	0.1	3.05
9/16	FH03305	0.1	2.85
5/8	FH03306	0.1	3.05
11/16	FH03307	0.1	2.85
3/4	FH03308	0.1	3.05
13/16	FH03309	0.2	3.05
7/8	FH03310	0.2	3.05
15/16	FH03311	0.1	3.05
1	FH03312	0.1	3.35
1 1/8	FH03313	0.1	4.05
1 1/4	FH03314	0.1	4.05
1 3/8	FH03315	0.2	4.75
1 1/2	FH03316	0.2	4.05

TAPER SHELL COUNTERSINK, STYLE 4

Designed for countersinking holes for flat-head screws. Center drill is held in place with set screws. Carbon steel. Please note that center drills are not included in the sale of countersinks.



Cent. Drill Dia. (in.)	OAL Length (in.)	Model	Shpg. Wt.	\$ Each
3/8	3/16	1 1/4 FH10401	0.01	11.20
1/2	1/8	1 1/4 FH10402	0.01	11.20
1/2	5/32	1 1/4 FH10404	0.01	12.25
1/2	3/16	1 1/4 FH10406	0.01	11.20
1/2	7/32	1 1/4 FH10408	0.01	11.20

COUNTERSINK HEX DRILL BIT SET

Includes Three Countersinks: #6, #8, & #10, Bright finish.



Shank Size (in.)	Pkg. Qty.	Model	Shpg. Wt.	\$ Each
1/4	3	FHDW2535	0.2	28.40

AUGER BITS

Hollow center flute quickly clears wood chips out of the hole. Spur-free cutting edge can be used near small nails. Forged construction provides long-lasting durability. 17" auger length; 12" twist length.



Bit Dia. (in.)	Shank Dia. (in.)	Model	Shpg. Wt.	\$ Each
3/8	5/16	FH03317	0.4	18.85
7/16	Hex 5/16	FH03318	0.5	18.90
1/2	5/16	FH03319	0.6	19.40
9/16	7/16	FH03320	0.8	20.35
5/8	7/16	FH03321	0.7	20.75
11/16	Hex 7/16	FH03322	1.0	22.15
3/4	7/16	FH03323	0.9	23.20
13/16	7/16	FH03324	1.1	24.35
7/8	7/16	FH03325	1.3	25.95
15/16	Hex 7/16	FH03326	1.4	26.20
1	7/16	FH03327	1.5	27.75
1 1/16	Hex 7/16	FH03328	1.7	32.35
1 1/8	7/16	FH03329	1.8	33.95
1 1/4	7/16	FH03330	2.1	39.10
1 3/8	Hex 7/16	FH03331	2.4	44.75
1 1/2	7/16	FH03332	2.8	47.50



BIT TIPS & DRIVERS

EXTRA HARD PHILLIPS® INSERT BITS

1/4 Hex Shank

Pkg. Qty. 1



Point Size	Body		Pkg. Qty.	Model	\$ Each
	Dia. (in.)	OAL (in.)			
1	1/4	1	2	FH03400	.70
2	1/4	1	5	FH03401	1.55
3	1/4	1	2	FH03402	.65

EXTRA HARD PHILLIPS® POWER BITS

1/4 Hex Shank



Size	Body			Pkg. Qty.	Model	\$ Each
	OAL (in.)	Pt. Size	Dia. (in.)			
1P	1	1	1 3/16	1	FH03403	1.20
2P	1	2	2 1/4	5	FH03404	4.90
3P	1	3	3 1/4	1	FH03405	.78
1P	3 1/2	1	1 3/16	1	FH03409	1.74
2P	3 1/2	2	2 1/4	1	FH03410	1.25
3P	3 1/2	3	3 1/4	2	FH03411	2.50

EXTRA HARD PHILLIPS® POWER BITS

1/4 Full Hex Body



Size	Body			Model	\$ Each
	OAL (in.)	Point Size	Dia. (in.)		
1P	6	1	1/4	FH03412	4.50
2P	6	2	1/4	FH03413	4.25
3P	6	3	1/4	FH03414	4.50

EXTRA HARD SLOTTED INSERT BITS

1/4 Hex Shank

Pkg. Qty. 1



OAL (in.)	Point Size	Pkg. Qty.	Model	\$ Each
1	4-5	1	FH03415	.58
1	6-8	2	FH03416	1.05
1	8-10	2	FH03417	1.05
1	10-12	2	FH03418	1.05

EXTRA HARD SLOTTED POWER BITS

1/4 Hex Shank



OAL (in.)	Point Size	Pkg. Qty.	Model	\$ Each
1 15/16	1-2	1	FH03419	2.50
1 15/16	2-3	1	FH03420	2.70
1 15/16	3-4	1	FH03421	2.70
1 15/16	4-5	1	FH03422	1.95
1 15/16	5-6	1	FH03423	1.00
1 15/16	6-7	1	FH03424	.80
1 15/16	8-10	1	FH03425	1.00
1 15/16	10-12	1	FH03426	.70
1 15/16	12-14	1	FH03427	3.20

EXTRA HARD SQUARE RECESS INSERT BITS

1/4 Hex Shank



OAL (in.)	Point Size	Nom. Size (in.)	Model	\$ Each
1	0	1/16	FH03428	1.15
1	1	3/32	FH03429	.93
1	2	1/8	FH03430	.95
1	3	9/64	FH03431	.95

MAGNA EXTRA HARD SQUARE RECESS POWER BITS

1/4 Hex Shank

Pkg. Qty. 1



OAL (in.)	Point Size	Nom. Size (in.)	Model	\$ Each
1 15/16	1	3/32	FH03432	.30
1 15/16	2	1/8	FH03433	1.20
1 15/16	3	9/64	FH03434	1.40
2 3/4	1	3/32	FH03435	1.95
2 3/4	2	1/8	FH03436	1.61
2 3/4	3	9/64	FH03437	1.80
3	1	3/32	FH03438	2.50
3	2	1/8	FH03439	2.21
3	3	9/64	FH03440	2.35
3 1/2	2	1/8	FH03441	3.15
4	1	3/32	FH03442	1.75
4	2	1/8	FH03443	3.35
4	3	9/64	FH03444	3.65
6	1	3/32	FH03445	4.20
6	2	1/8	FH03446	4.02
6	3	9/64	FH03447	4.20

TORX® INSERT BIT 1/4 Hex Shank

This style provides positive torque control with no cam outs, and allows maximum drive surface and longer drive life.

Point Size	OAL (in.)	Pkg. Qty.	Model	\$ Each
T6	1	1	FH03448	1.25
T7	1	1	FH03449	1.25
T8	1	1	FH03450	1.25
T9	1	1	FH03451	1.25
T15	1	1	FH03452	1.30
T20	1	1	FH03453	1.00
T25	1	1	FH03454	1.00
T27	1	1	FH03455	1.15
T30	1	1	FH03456	1.20
T40	1	1	FH03457	1.20

TORX® POWER BIT 1/4 Hex Shank



Point Size	OAL (in.)	Pkg. Qty.	Model	\$ Each
T15	2	1	FH03458	1.85
T20	2	1	FH03459	1.85
T25	2	1	FH03460	1.85
T30	2	1	FH03461	2.25
T40	2	1	FH03462	2.00
T15	2 3/4	1	FH03463	2.80
T20	2 3/4	1	FH03464	2.85
T25	2 3/4	1	FH03465	2.30
T15	3 1/2	1	FH03466	2.30
T20	3 1/2	1	FH03467	3.15
T25	3 1/2	1	FH03468	2.65
T10	6	1	FH03469	3.80
T15	6	1	FH03470	3.70
T20	6	1	FH03471	3.80
T25	6	1	FH03472	3.80

SOCKET HEX HEAD INSERT BIT 1/4 Hex Shank

Point Size	OAL (in.)	Pkg. Qty.	Model	\$ Each
5/64	1	1	FH03473	1.25
3/32	1	1	FH03474	1.25
7/64	1	1	FH03475	1.25
1/8	1	1	FH03476	1.25
9/64	1	1	FH03477	1.25
5/32	1	1	FH03478	1.30
3/16	1	1	FH03479	1.30
7/32	1	1	FH03480	1.30
1/4	1	1	FH03481	1.30

STANDARD REVERSIBLE INSERT KNIVES

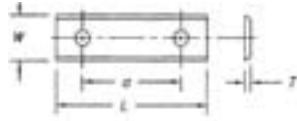

2 SIDED 2 HOLES

Description	L x W x T (in.)	Model	Shpg. Wt.	\$ Each
2 Sided 2 Holes	50 x 12 x 1.5 26 CTC	FH501215	0.1	32.00
2 Sided 2 Holes	60 x 12 x 1.5 26 CTC	FH601215	0.1	46.00

SELF CENTERING DRILL GUIDES (VIX BITS)

Designed to drill centered screw holes for cabinet and builders hardware.



Drill Dia. (in.)	Screw Size	Shank Dia. (in.)	OAL Length (in.)	Model	Shpg. Wt.	\$ Each
5/64	3 & 4	1/4	3	FH56401	0.2	11.00
7/64	5 & 6	1/4	3 1/4	FH76401	0.2	9.85
9/64	8, 9 & 10	1/4	3 1/2	FH96401	0.2	10.35
11/64	12	3/8	5	FH116401	0.2	39.95
13/64	14	3/8	4 1/2	FH136401	0.2	39.95

SQUARE DRIVE SOCKET ADAPTERS

Allow the user to adapt a power drill into a socket driver. Made of alloy tool steel. Use with power drills and 1/4" hex drive hand tools.



Drive Size (in.)	Length (in.)	Model	Shpg. Wt.	\$ Each
1/4	1 3/8	FH03500	0.1	1.75
1/4	2	FH03501	0.2	2.55
3/8	2	FH03502	0.2	3.55
1/2	2	FH03503	0.1	3.75

NASCO SCREWFEEEDER BITS



FH03517



FH03519

Desc.	Model	Shpg. Wt.	\$ Each
1L Feeder Bit w/threaded Shank	FH03517	0.5	5.50
Six Shooter Bit w/Spring	FH03519	0.5	8.50

1/4" HEX DRIVE REVERSIBLE SCREWDRIVER HANDLE

Drives all 1/4" hex shank insert bits or adapters, and doubles as 1/4" hex head screw- and nut driver. Magnet holds insert bits securely in place and direction-reversing switch located for easy one-hand operation. Integrated storage compartment holds extra bits.



Length (in.)	Model	Shpg. Wt.	\$ Each
7	FH03504	0.5	10.25

1/4" HEX DRIVE INSERT BIT HOLDERS

Unsurpassed magnetic power holds insert bits in place. Models with C-ring design add internal clip in the retaining ring notch to hold bit more securely. Can be used with socket wrench or socket adapter.

FH03505



FH03509



FH03507



LOCATOR/ DRIVER

FH03510



Shank Size (in.)	Length (in.)	Pkg. Qty.	Model	Shpg. Wt.	\$ Each
1/4 Square	3	3	FH03505	0.5	15.20
1/4 Square	2 1/4	3	FH03506	0.4	14.30
1/4 Hex (Locator/Driver)	4 11/16	2	FH03507	0.1	7.95
1/4 Square Drive	1	—	FH03508	0.1	3.60
3/8 Square drive	1 1/4	—	FH03509	0.2	4.60

FLUSH CUTTING TRIM SAW ASSEMBLY

Flush-cutting trim saw features a solid carbide blade permanently mounted on a shank 1 1/4" OAL. Ideal for Kerfing.

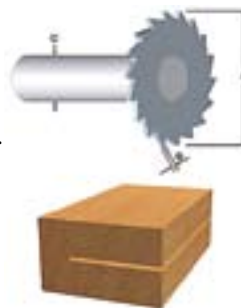

A. Cutter Dia. (in.)	B. Kerf (in.)	C. Shank Dia. (in.)	Model	Shpg. Wt.	\$ Each
1 5/8	3/64	1/4	FH03519	1.0	54.00

1/4 HEX SHANK NUTSETTER POWER/MAGNETIC

Size (in.)	OAL (in.)	Hex Open	Model	Pkg. Qty.	\$ Each
MSH 1/4	1 5/8	1/4"	FH03510	3	4.55
MSH 5/16	1 5/8	5/16"	FH03511	3	5.60
MSH 3/8	1 1/8	3/8"	FH03512	3	6.45
MSHL 1/4	2 9/16	1/4"	FH03514	3	6.30
MSHL 5/16	2 9/16	5/16"	FH03515	3	6.95
MSHL 3/8	2 9/16	3/8"	FH03516	3	9.20
MSHL 7/16	2 9/16	7/16"	FH03517	3	9.60

CARBIDE-TIPPED THREE FLUTE SLOTTING CUTTERS

Carbide tipped 3-wing slotting cutters are micrograin bits for making slots for T-molding and weather stripping. 1/2" Depth of Cut.



A. Cutter Dia. (in.)	B. Kerf (in.)	C. Arbor Hole (in.)	Model	Shpg. Wt.	\$ Each
1 7/8	1/16	5/16	FH03520	1.0	14.95
1 7/8	5/64	5/16	FH03521	1.0	15.70
1 7/8	3/32	5/16	FH03522	1.0	15.70
1 7/8	1/8	5/16	FH03523	1.0	16.50
1/4" Shack & Bearing			FH03524	1.0	5.50

TABLE SAWS

DELTA 10" TABLE SAW

Features a 3 HP, 230V, 60 Hz, 3450 rpm single-phase motor with push-button station magnetic starter. Has TEFC motor enclosure, equipment mounting hooks, see-through blade guard, miter gage, and table insert. Comes with a dust port for 4" collection hose, The FH36-953B comes with a Biesemeyer® 30" commercial fence with extension legs, and laminated extension table.

JOBSITE

Innovative, telescoping rack and pinion fence. Coated cast aluminum top. Includes stand, 24-tooth carbide blade, and miter gauge.

FH36-953B



FH36-953



FHDW744 JOBSITE



Desc.	Blade Size (in.)	Rip Capacity (in.) L	Rip Capacity (in.) R	Depth of Cut (In.) 45°	Depth of Cut (In.) 90°	Table Dimensions (in.) H x W x D	No-Load RPM	Amps @ 230V	Arbor Hole (in.)	Brand	Model	Shpg. Wt.	\$ Each
Table Saw/ Fence	10"	12	30¼	2⅞	3	36¾ x 64 x 27	3450	20.0	5/8	Delta	FH36-953B	469.0	1819.00
Table Saw	10"	12	15½	2⅞	3⅞	27 x 36 x 27	3450	20.0	5/8	Delta	FH36-953	372.0	1580.00
Jobsite Saw	10"	15½	24½	2⅞	3⅞	29 x 21½	3650	—	5/8	DeWalt	FHDW744	91.0	554.00

TABLE SAW ACCESSORIES

Description	Brand	Model	Shpg. Wt.	\$ Each
Dado Throat Plate for Jobsite Saw (allows for use of stack dado cutters)	DeWalt	FHDW7444	1.7	49.95
Table Saw Stand for Jobsite Saw	DeWalt	FHDW7440	28.0	104.95
Saw Out-feed Support for Jobsite Saw	DeWalt	FHDW7441	12.4	107.50
8" Dado Saw Blade Set	Delta	FH35-7670	9.0	173.50

RADIAL ARM SAWS

Bevel capacities: 0°, 45°, and 90°. 5/8" arbor hole. Saws include: blade, blade wrenches, and instruction manual.

10" PROFESSIONAL RS830

Miter scale has large 0° to 45° markings left and right for easy selection of miter setting. Depth-of-cut control handle locking levers are positioned above the table for easy access. Easy-to-read inboard and outboard rip scale.

- ♦ Automatic blade brake stops blade in seconds
- ♦ Cast-iron track, column, and column support assure rigidity and accuracy
- ♦ Steel stand for sturdy support
- ♦ Extra-large 27D x 44"W table for wide panels or large workpieces.

12" INDUSTRIAL 33-890

Turret arm action permits saw blade to rotate 360° above work table; provides full table capacity for left and right hand miters. Precision indexing with positive stops for 90° and 45° miter cuts. Truck rods feature smooth hardened surfaces to minimize rolling friction. May be rotated 180° for new bearing surface. Includes blade guard with antikickback attachment and retractable leaf guard.

- ♦ Built-in mechanical brake stops blade in seconds
- ♦ Rigid channel, cast-iron frame, and heavy column assure alignment
- ♦ Steel stand for sturdy support
- ♦ On/Off key lock switch and set of legs
- ♦ Overload protection
- ♦ 25 1/2D x 30"W table



FHR830



FH33-890

Blade Dia. (in.)	Motor HP	Phase	Voltage	Crosscut Width @ 90°	Crosscut Depth @ 90°	No-Load RPM	Miter Capacity (Deg.)	Rip Capacity (in.)	Brand	Model	Shpg. Wt.	\$ Each
10	1½	1	120/240	16	2¾	3450	0, 45 R/L	16	Delta	FHR830	182.0	1395.00
12	2	1	230	14¾	3¾	3450	45, 90 R/L	24¼	Delta	FH33-890	293.0	2095.00

4 1/2" SANDERS/GRINDERS

Multi-position side handle offers greater control and comfort. Has metal gear case, spindle lock, and ball and roller bearings. Includes type 27 wheel, wrench, guard, backing flange, and clamp nut for 7/8" non-threaded wheels. Includes: Type 27 Wheel, Wrench, Multi Position Side Handle, Guard, Backing Flange and Clamp Nut for 7/8" Non Threaded Wheels



Amps @ 120V	No Load RPM	Spindle Thread Size (in.)	Tool Weight (lbs)	Model	Shpg. Wt.	\$ Each
10.0	11,000	5/8 - 11	4.6	FHD28402	7.0	89.00

TYPE 27 GRINDING WHEELS

Aluminum Oxide General Purpose Grinding and cutting Wheels- Metal Grinding Long Life.

Arbor Dia. (in.)	Hole (in.)	Max RPM	Model	Shpg. Wt.	\$ Each
4½	7/8	13,300	FHDW4514	0.4	1.95
4½	5/8-11	13,300	FHDW4523	0.5	3.05
5	7/8	12,200	FHDW4619	0.4	2.70
5	5/8-11	13,300	FHDW4623	0.6	3.65
7	7/8	8700	FHDW4719	0.9	3.95
7	5/8-11	6600	FHDW4999	1.1	5.30

JIG SAWS



Strokes per Min.	Amps @ 120V	Battery Voltage	Length of Stroke	Speed Type	Blade Type	Includes	Brand	Model	Shpg. Wt.	\$ Each
0-3,100	5.5	—	1"	Variable	Universal & T-Shank	Jig Saw, Blade Kit Box	DeWalt	FHDW317K	9.8	108.95
500-3,100	6	—	1"	Variable	Universal & T-Shank	Saw, Blade, non-marring base insert for delicate surfaces, anti-splinter base insert, heavy-duty case	P/C	FHPC9543	10.0	195.95
500-3,100	5	—	1"	Variable	Universal & T-Shank	Saw, 9 Blades, Footplate adjustment hex key, 2 Footplate Insert Kits, Anti-Splintering Insert & Carrying Case	Bosch	FH1587AVSK	15.0	139.95
0-3,000	—	18.0	1"	Variable	Universal & T-Shank	Saw, XRP Battery, Charger, 3 Jigsaw Blades, Kit Box, & Dust Blower	DeWalt	FHDC330K	12.6	276.95
0-2,700	—	36.0	1"	Variable	Universal & T-Shank	Keyless Blade Change And Dust Blower, 1 Hr. 120V Charger, 1 Battery, Blade, and Carrying Case	DeWalt	FHDC308K	15.4	432.95

UNIVERSAL JIG SAW BLADES



Recommended Use	Tooth P/in.	Tooth Type	Length (in.)	Blade Width (in.)	Blade Material	Qty.	Model	Shpg. Wt.	\$ Each
Special Purpose Cutting									
Deluxe blade for fast scroll and pocket	6	-	4 1/8	-	Bi-metal	5	FH12527	0.1	13.49
Smoother scroll and circular cutting	10	-	4 1/8	-	Bi-metal	5	FH12528	0.1	11.58
Deluxe blade for straight and smooth cutting	10	-	4	-	Bi-metal	5	FH12529	0.1	15.74
Scroll and super smooth cutting	20	Taper	2 3/4	3/16	HS	5	FH12520	0.1	7.50
Fast, rough and circular cutting	6	Set	4	5/16	HC	5	FH12521	0.1	6.24
Smoother scroll and circular cutting	8	Set	4	5/16	HC	5	FH12522	0.1	6.24
Smooth, fast scroll and pocket cutting	6	Taper	4	1/4	HC	5	FH12523	0.1	8.73
Fine, straight and scroll cutting	10	Taper	4	1/4	HC	5	FH12524	0.1	11.58
Deluxe blade makes fast, smooth, deeper cuts	10	Taper	3 5/8	1/4	HS	5	FH12508	0.1	13.12
Deluxe blade for straight, deep, smooth cutting	6	Taper	3 5/8	3/8	HS	5	FH12509	0.1	13.12
Veneer, non-chip, down cutting action	10	Taper	4	1/4	HC	5	FH12525	0.1	12.83
Cutting rail-embedded wood and abrasives	12	Set	3 5/8	5/16	HS	5	FH12515	0.1	12.20
Metal Cutting									
Variable tooth medium gauge metal cutting	10/14	-	3 5/8	-	Bi-metal	5	FH12530	0.1	12.20
Fiberglass and heavy gauge metal cutting	13	Set	2 3/4	5/16	HS	5	FH12516	0.1	7.50
Cutting Pipe, tubing and medium gauge metal	17	Set	2 3/4	5/16	HS	5	FH12517	0.1	7.50
Ferrous metals, medium gauge	21	Set	2 3/4	5/16	HS	5	FH12518	0.1	7.50

T-Shank also available call FHS for inquiries.

COMPOUND MITER SAWS

12" MITER SAWS

Removable saw fence expands cutting capacity up to 2 x 16" at 90° and 2 x 12" at 45°.

15-amp motor offers left and right hand 50° miter capacity. Adjustable detent platen with override capability and detent plate accommodate out of square corners. Cam action miter lock and laser compatible. FHDW716 and FHDW718 have double bevel and belt-drive design; FHDW715 has bevel crown stop. Built-in carrying handle, dust bag extension kit, and wrench included.



FHDW715



FHDW716



FHDW718



FHDW703

10" HEAVY-DUTY MITER SAW DW703

Stainless steel detent plate has 11 positive stops for accuracy and durability.

0-50° miter capacity and 0-48° bevel capacity. Tall sliding fence supports up to 4 1/2" crown molding. Includes 40-tooth carbide blade, dust bag, and blade wrench



FH5412L

12" DUAL-BEVEL SLIDE MITER SAW 5412L

- Upfront Controls & Laser Tracking
- The first and only 12" dual-bevel slide miter saw with upfront bevel controls
- New Arbor Laser Tracking for precision cutting



FH4212L

12" DUAL-BEVEL COMPOUND MITER SAW 4212L

- Upfront Controls & Laser Tracking
- Multi-position main handle & 2 sliding fences with scales
- New Arbor Laser Tracking for precision cutting



FH4410L

10" DUAL-BEVEL SLIDE MITER SAW 4410L

- Upfront Controls & Laser Tracking
- New Arbor Laser Tracking for precision cutting
- Microfine miter adjustment knob

Blade Dia, (in)	Arbor Hole (in.)	Bevel	Slide	No Load RPM	Amps @ 120V	Tool Weight	Miter Capacity	Bevel Capacity	Features	Brand	Model	Shpg. Wt.	\$ Each
12	5/8 & 1	Yes	No	4,000	15	42.0	50°	48°	32 Tooth Blade, Dust Bag Extension Kit And Wrench	DeWalt	FHDW715	52.0	348.95
10	5/8	Yes	No	5,000	15	33.0	50°	48°	40 Tooth Carbide Blade, Dust Bag and Blade Wrench	DeWalt	FHDW703	40.4	238.95
12	5/8 & 1	Yes	No	3,600	15	44.0	50°	48°	60 Tooth Blade, Dust Bag Extension Kit And Wrench	DeWalt	FHDW716	53.0	418.95
12	5/8 & 1	Yes	Yes	3,600	15	53.0	51°L/60°R	48°	60 Tooth Blade, Dust Bag Extension Kit And Wrench	DeWalt	FHDW718	67.0	698.95
12	1	Yes	Yes	3,800	15	59.0	52°L/60°R	47°	60-Tooth Carbide Blade, Wrench Set, Tool-Free Vertical Work Clamp & Dust Bag	Bosch	FH5412L	80.0	698.95
12	1	Yes	Yes	3,800	15	55.0			40-Tooth Carbide Blade, Dust bag, Elbow wrench set & Flip-over Crown Stops	Bosch	FH4212L	80.0	395.98
10	5.8	Yes	Yes	4,800	15	55.0	52°L/60°R	47°L/46°R	60-Tooth Carbide Blade, Wrench Set, Tool-Free Vertical Work Clamp & Dust Bag	Bosch	FH4410L	80.0	549.95

CIRCULAR SAWS



CORDLESS CIRCULAR SAWS

Blade Dia. (in)	No Load RPM	Amps @ 120V	Battery Volts	Tool Weight	Depth of Cut 90°	Depth of Cut 45°	Bevel Capacity	Includes	Brand	Model	Shpg. Wt.	\$ Each
7 1/4	5,800	15	-	9.5	2 3/8	1 3/4	56°	Carbide Tipped Blade, Blade Wrench	DeWalt	FHDW368K	12.9	133.95
7 1/4	5,800	15	-	9.6	2 5/16	1 13/16	50°	18 Teeth Carbide Tipped Blade, Blade Wrench & Carrying Case	P/C	FH324MAG	17.1	144.95
7 1/4	5,600	15	-	10.2	2 7/16	1 7/8	56°	24 Tooth Carbide Blade, Carrying Bag	Bosch	FHCS10	19.2	136.95
5 3/8	3,000	-	14.4	6.5	1 5/8	1 1/8	45°	16 Tooth Blade, Charger, Carry Case, Battery	DeWalt	FHDW935K	13.2	202.95
6 1/2	3,700	-	18	8.8	1 9/16	1	45°	16 Tooth Blade, 1 Hour 120 Volt Charger, 1 Battery, Blade Wrench, Carrying Case	DeWalt	FHDC390K	16.4	210.95
7 1/4	4,000	-	36	9.9	2 7/16	1 5/8	50°	24 Tooth Blade, 1 Battery, 1 Hr. 120V Charger, Wrench, Rip Fence, and Carrying Case	DeWalt	FHDC300K	19.4	412.95

CARBIDE-TIPPED CIRCULAR SAW BLADES

Blade Dia. (in.)	No. of Teeth	Kerf	Tooth Grind (†)	Hook Angle	Arbor Hole (in.)	Plate Thickness (in.)	Model	Shpg. Wt.	\$ Each
Construction Saw Blades – General Purpose									
10	32	0.095	ATB	+5°	5/8	0.069	FHDW3103	1.8	33.95
12	32	0.095	ATB	-5°	1	0.069	FHDW3123	2.6	58.05
Construction Saw Blades – Ripping									
10	24	0.095	ATB	+1.5°	5/8	0.069	FHDW3112	1.8	33.05
Construction Saw Blades – Fast Cut Framing									
7 1/4	18	0.071	ATB	+1.5°	5/8	0.045	FHDW3191	0.5	14.05
Construction Saw Blades – Combination Framing									
10	40	0.095	ATB	+5°	5/8	0.071	FHDW3114	1.8	26.55
Construction Saw Blades – Carbide Treated for Pressure Treated/Wet Lumber									
7 1/4	20	0.071	ATB	+25°	5/8	0.045	FHDW3174	0.6	15.87
Construction Saw Blades – Finishing									
7 1/4	36	0.076	ATB	+15°	5/8	0.045	FHDW3176	0.7	18.07
7 1/4	24	0.076	ATB	18°	5/8	0.045	FHDW3178	0.5	12.93
10	60	0.095	ATB	+5°	5/8	0.071	FHDW3106	1.8	32.35
12	80	0.095	ATB	+5°	1	0.071	FHDW3128	2.6	53.70
Thin Kerf, Antistick Saw Blade, Ripping									
7 1/4	20	0.071	ATB	25°	5/8	0.045	FHDW3574	0.5	12.57
Steel Saw Blades for Fast, Semi-Smooth Rips, Crosscuts & Miter, General Purpose									
7 1/4	40	—	—	—	5/8	—	FHDW3325	0.5	7.79

CONSTRUCTION SAW BLADES

Computer-balanced plate reduces vibration for improved accuracy and better finish. Thin Kerf design for fast, smooth cutting. Fully hardened, heat-treated steel body retains its extreme flatness for a more accurate cutting line.

STEEL SAW BLADES

Fully hardened thick steel body is designed for heavy-duty application. Precision-sharpened teeth cut faster. Coated to reduce friction and prevent rust.



RECIPROCATING SAWS

CORDLESS RECIPROCATING SAWS



FHDW937K



FHDC385K



FHDC305K

Volts	Blade Stroke (in.)	Speed	Cutting Action	Weight (lbs.)	Tool Length (in.)	Includes	Brand	Model	Shpg. Wt.	\$ Each
14.4	7/8	0-2,700	Straight	6.0	17 1/2	Charger, XR Battery, Carry Case	DeWalt	FHDW937K	12.35	212.95
18	1 1/8	0-3,000	Straight	6.5	17 1/2	1 Hour 120 Volt Charger, XR Battery, 1 Blade, Carry Case	DeWalt	FHDC385K	12.0	210.95
36	1 1/8	0-3,000	Straight	8.4	17	1 Battery, 1 Hr. 120V Charger, Blade and Carrying Case	DeWalt	FHDC305K	16.1	412.95

ELECTRIC RECIPROCATING SAWS



FHDW310K



FHDW311K



FHR510

Amps	Blade Stroke (in.)	Speed	Keyless Blade Clamp	Adj. Shoe	Weight (lbs.)	Tool Length (in.)	Includes	Brand	Model	Shpg. Wt.	\$ Each
12.0	1 1/8	0-2,700	Yes	Yes	6.9	17	Adjustable Shoe, and Blade	DeWalt	FHDW310K	13.75	146.95
11.5	1 1/8	0-2,600	Yes	Yes	9.0	10	Soft Grip Handle, Variable Speed Dial Control, Orbital Adjustable Shoe, and Blade	DeWalt	FHDW311K	14.0	182.95
13.0	1 1/4	0-1,900 0-2,800	Yes	Yes	8.4	18	All Purpose Blade, Carrying Case, Wood with Nails Blade	Bosch	FHR510	13.5	139.95

RECIPROCATING TIGER SAW BLADES



Recommended Use	Length (in.)	Teeth P/in.	Blade Width (in.)	Qty.*	Model	Shpg. Wt.	\$ Each
Progressive Tooth (Cordless)							
Fast, splinter-free cuts in wood material	8	Progressive	3/4	3	FH14088-3	0.1	13.99
Fast cutting in thick and thin metal and plastic	6	Progressive	3/4	3	FH14051-3	0.1	13.70
Fast and durable for general purpose cutting	6	Progressive	3/4	3	FH14043-3	0.1	15.43
Progressive Tooth (Corded)							
Fast, splinter-free cuts in wood material	8	Progressive	3/4	5	FH14087-5	0.1	20.50
Fast cutting in thick and thin metal and plastic	6	Progressive	3/4	5	FH14068-5	0.1	20.10
Fast and durable for general purpose cutting	8	Progressive	3/4	5	FH14085-5	0.1	26.92
Wood (High Carbon)							
General roughing-in wood	6	6	3/4	5	FH12400-5	0.1	9.70
General roughing-in wood	6	6	3/4	5	FH12402-5	0.1	17.24
General roughing-in wood	3	3	3/4	5	FH12478-5	0.1	26.92
Wood (Bi-Metal)							
General roughing-in wood and nail-embedded wood	6	5/8	3/4	5	FH14050-5	0.1	19.08
General roughing-in wood and nail-embedded wood	6	5/8	3/4	5	FH14045-5	0.1	17.70
General roughing-in wood and nail-embedded wood	6	6	3/4	5	FH14060-5	0.1	15.43
General roughing-in wood and nail-embedded wood	9	5/8	3/4	5	FH12470-5	0.1	21.65
General roughing-in wood and nail-embedded wood	12	5/8	3/4	5	FH14080-5	0.1	27.50

*Larger quantities available

Two new saws every Door Shop should have...

EVOLUTION RAGE MULTIPURPOSE SAWS

Ever want to cut down a residential metal door?
 Ever want to cut down a commercial hollow metal door?
 Ever want to cut down metal frames?
 Now you can just like wood doors and jambs.
And better yet. You only need to buy one saw to do both.

Cuts steel, aluminum, wood and fiberglass all with the same blade. Perfect for cutting both metal and wood studs. No need to worry about nails or staples.

How does it work? A combination of Hi-torque motor and low speed gearbox, heavy duty construction and an ultra high grade TCT blade enables this saw to cut materials which simply weren't possible before.



EVOLUTION RAGE - FH10001
RAGE 7 1/4" TCT Multipurpose Circular S.A.W.



EVOLUTION RAGE 3 - FH10003
10" TCT Multipurpose Sliding Miter S.A.W.
 Perfect for cutting all types of sills in your exterior door shop

Description	Blade Size	Motor (Watt)	Speed RPM	Max Duty Cycle	Tool Weight	Depth of Cut 90°	Depth of Cut 45°	Width of Cut 90° Mitre	Width of Cut 45° Mitre	Bevel Capacity	Model	Shpg. Wt.	\$ Each
RAGE Multipurpose Circular S.A.W.	7 1/4"	1050	3500	30 mins.	14.3 lbs.	2 1/8"	1 3/8"	—	—	90°-45°	FH10001	19.0	149.99
RAGE 3 Multipurpose Cut Off S.A.W.	10"	2000	2500	30 mins.	39.3 lbs.	2 1/2"	1 9/16"	11 ¹³ / ₁₆ "	8 1/4"	—	FH10003	45.0	275.00

BLADES FOR THE EVOLUTION RAGE

Blade life isn't sacrificed when cutting tough materials. A blade can cut up to 164 ft. or 1/4" mild steel before a replacement is required.

Blade Dia. (in.)	Max Speed	Bore	Kerf	Teeth	Model	Shpg. Wt.	\$ Each
7 1/4	3500 RPM	20mm	2mm	20	FH10004	0.3	24.99
10	2500 RPM	25.4mm	2mm	28	FH10005	0.3	63.00

18V CORDLESS FINISH NAILERS

No hose required, giving the operator unlimited mobility.

Nailer works as fast as the user can. A numbered dial lets you set depth. Engaging contact trip lock-off prevents accidental discharge. Has sequential mode for precision placement and bump mode for production speed. Includes 1-hr. 120V charger, battery, reversible belt hook, replaceable no-mar tip, safety glasses, and carrying case.



FHDC616KA



FHDC618KA



FINISHING FASTENERS

16 Gauge Galvanized Shank • 2,000 per box

Length (in.)	Model	Shpg. Wt.	\$ Each
Finish Fasteners for use with FHDC616KA			
1 1/4	FH11000	2.2	8.15
1 1/2	FH11001	5.2	9.05
1 3/4	FH11002	3.1	9.80
2	FH11003	4.4	10.00
2 1/4	FH11004	5.0	10.60
2 1/2	FH11005	5.6	13.45
Angle Finish Fasteners for FHDC618KA			
1 1/4	FH11006	2.2	11.75
1 1/2	FH11007	2.6	12.75
1 3/4	FH11008	3.0	15.30
2	FH11009	3.5	16.35
2 1/2	FH11010	4.3	17.35

Volts	Fastener Range (in.)	Fastener Type	Magazine	Mag. Capacity	Tool Weight (lbs.)	Tool Length (in.)	Includes	Brand	Model	Shpg. Wt.	\$ Each
18	1 1/4 - 2 1/2	16 Gauge	Straight	120	8.5	12.5	Charger, 1 Battery, Reversible Belt Hook, 1 No Mar Tip, Safety Glasses, Carrying Case	DeWalt	FHDC616KA	15.6	337.95
18	1 1/4 - 2 1/2	16 Gauge	20° Angle	120	8.5	12.5	Charger, 1 Battery, Reversible Belt Hook, 1 No Mar Tip, Safety Glasses, Carrying Case	DeWalt	FHDC618KA	16.0	343.95

ROUTERS

ROUTER ACCESSORIES



FHP C100



FHP C690



FHDW616



FHP C691



FHBOS1617



FHDW618



FHP C7519



FHP C7518

Desc.	For Use With	Model	Shpg. Wt.	\$ Each
Router Edge Guide	DeWalt Routers	FHDW6913	3.6	52.95
Plunge Base	FHDW616 & FHDW618	FHDW6182	5.4	152.95
D-Handle Base	FHDW616 & FHDW618	FHDW6183	4.1	123.95
Fixed Base	FHDW616 & FHDW618	FHDW6184	2.3	75.95

HP	Amps @ 120V	No Load RPM	Tool Length (in.)	Tool Weight (lbs.)	Switch	Includes	Brand	Model	Shpg. Wt.	\$ Each
7/8	6.5	22,000	7	7	Toggle	Compact, Die-cast Alum, 1/4" Collet, 2 Wrenches	P/C	FHP C100	8.4	192.95
1 3/4	10	27,500	8	8	Rocker	Compact, Die-cast Alum, 1/4 & 1/2" Collets, 2 Wrenches	P/C	FHP C690	9.4	194.95
1 3/4	11	24,500	10 1/8	7.1	Toggle	1/4 & 1/2" Collets, Concentricity Gauge & 2 Wrenches, Micro Fine Depth Adjustment	DeWalt	FHDW616	10.0	194.95
1 3/4	11	27,500	8	9.25	Trigger	D Handle Power Router, Compact, Die-cast Alum, 1/4 & 1/2" Collets, 2 Wrenches	P/C	FHP C691	10.6	208.95
2	11	25,000		7.5	R or L	Coarse and micro-fine bit depth adj, 1/4 & 1/2" Collets, 2 Wrenches, Tool-Free Templet Guide Adp. and Chip Shield	Bosch	FHBOS1617	11.2	164.95
2 1/4	12	8,000 - 24,000	10 1/8	7.2	Toggle	Micro Fine Adj., 1/4 & 1/2" Collets, Variable Speed, Soft Start, Concentricity Gauge, Wrench & Large Hole Sub-base	DeWalt	FHDW618	9.9	222.95
3 1/4	15	21,000	11			Router, 1/2" collet and collet wrenches	P/C	FHP C7519	18.0	349.95
3 1/4	15	5- speed 10,000 - 21,000	11			5-Speed Router, 1/2" collet and collet wrenches	P/C	FHP C7518	18.0	369.95

SHAPER TABLE AND TEMPLATE GUIDES

ROUTER TEMPLATE GUIDE KIT

Kit includes seven template guides, 2 locknuts, and a plastic case.

FHP C42000



HEAVY-DUTY SHAPER TABLE

Aluminum table top has 3 5/8" hole. Dust collection hood for 2 1/2" hose. Use with Porter Cable models 514, 518, 520, 630, 690, 691, 7529, 7537, 7538, 7539, 7518, and 7519. Has a 3/4" miter gauge slot. Split fence with micro base.



FHP C698

Description	Model	Shpg. Wt.	\$ Each
Shaper Table	FHP C698	34.0	201.00
Router Template Guide Kit	FHP C42000	1.0	39.40

PLUNGE ROUTERS



HP	Amps @ 120V	No Load RPM	Tool Weight (lbs.)	Switch	Includes	Brand	Model	Shpg. Wt.	\$ Each
3¼	15	21,000	17.2	Trigger	Plunge, Adj. Depth Rod, Soft Start, Self-Releasing 1/2" Collet	P/C	FHPC7538	20.6	386.95
3¼	15	5- speed 10,000-21,000	17.2	Trigger	Plunge, Adj. Depth Rod, Soft Start, Self-Releasing 1/2" Collet, 5-Speed, Precision Machined Posts	P/C	FHPC7539	20.0	416.95
1¾	11	27,500			Micrometer depth-of-cut adjustment, Router, 1/4" & 1/2" collet, collet wrenches, carrying case and plunge base	P/C	FHPC693PK	20.75	209.95
2	10/9	8,000-24,000	9.0	Trigger	Plunge, Variable Speed Control, On/Off built into handle, Soft Start, Spindle Lock, 1/4 & 1/2" Collets, Template Guide, Bushing & Vacuum Adapter, Wrench	DeWalt	FHDW621	12.6	253.95
3	15	8,000-22,000	11.3	Slide	Plunge, Variable Speed Control, Soft Start, Spindle Lock, 1/4 & 1/2" Collets, Template Guide, Bushing Adapter, Wrench	DeWalt	FHDW625	16.9	314.95
2	12	25,000	19.5	R or L	Plunge Router, 3 Wrenches, Tool-free Templet Guide Adapter, 2 Chip Shields, Carrying Case, Fixed Base, 1/4" & 1/2" Collet Chucks	Bosch	FH1617PK	20.0	212.95

CUT-OUT TOOLS

Make fast and accurate cut-outs in drywall, cement board, ceramic wall tile, plaster, paneling, and acoustical tile.

Keyless tool-free bit change. Features spindle lock, soft-grip body, plastic adjustable foot, radial fan, 1/4 and 1/8" bit capacity, two position On/Off switch, adjustable air diverter, and dust-sealed switch.



Volt	Amps @ 120V	No Load RPM	Tool Length (in.)	Tool Weight (lbs.)	Includes	Model	Shpg. Wt.	\$ Each
18	—	26,000	10.25	7.2	Charger, 2 batteries, 2 bits 1/4 and 1/8" collet and kit box	FHDC550KA	11.3	233.95
—	5	30,000	10	3.2	2 bits 1/4 and 1/8" collet and kit box	FHDW660	3.6	69.95

ZIP BITS®

Cuts	Made from	Bit Dia. (in.)	Pack Qty.	Model	Shpg. Wt.	\$ Each
Window and Door Cutouts	High Speed Steel	1/4	1	FH11050	0.1	6.45
Wood, Fiberglass	High Speed Steel	1/8	5	FH11052	0.5	7.45
Up to 18-Gauge Steel	Carbide	5/32	1	FH11054	0.1	19.00
Ceramic Tile, Cement Board, Stucco, Plaster	Carbide	1/8	1	FH11055	0.1	7.10



LAMINATE TRIMMERS



FHPC7319

ADJUSTABLE LAMINATE TRIMMER

Compact, lightweight design with 360° access to unit for greater control, safety, and durability during operation. Precision-machined aluminum base tilts 45° left and 30° right. Double-insulated sealed 100% ball bearing construction. AC/DC power source.



FHD26670

LAMINATE TRIMMER

The DEWALT FHD26670 Heavy-Duty Laminate Trimmer has precise height-adjustment screws and 24-tpi rods. Combined with a 1-3/8" collet depth, the 670 is ideal for making small to medium-sized cuts in a variety of woods.

USE FOR FACE PLATE MORTISING ON YOUR D3001M



FHDW670

FIXED BASE LAMINATE TRIMMER

Unique micro-set depth adjustment for pinpoint accuracy in seconds. Die-cast, precision-machined, fixed aluminum base. Double sealed 100% ball bearing construction. AC/DC power source.



FHPC7310

COLT™ SINGLE-SPEED PALM ROUTER

- 1.0 HP - Highest rating among small routers
- Great for rounding-over deck planks and railings, hinge mortising, decorative edge forming, slot cutting, dovetailing, window cutouts, decorative inlays, laminate trimming and more.
- Power and precision in the palm of your hand.



FHPR10E

Amps @ 120V	No Load RPM	Switch	Tool Weight (lbs.)	Collet Cap. (in.)	Bearings	Base Material	Includes	Brand	Model	Shpg. Wt.	\$ Each
5.6	30,000	Slide	4.0	1/4	100% Sealed Ball	Aluminum	R & L Tilt, Compact, Lightweight, Design with 360° Access to Unit, Spindle Lock for Fast Bit Changes, AC/DC Power Source	P/C	FHPC7319	5.0	161.95
5.6	30,000	Slide	3.7	1/4	Ball	Lexan	Tool Free Base Change And Height Adjustment, 5" Diameter Round Base, Ball Bearing Guide, Wrench	DeWalt	FHD26670	5.5	120.95
5.6	30,000	Slide	3.65	1/4	Ball	Lexan	Tool-free Base Change and Height Adjustment, Precision-machined 360° Trim Base	DeWalt	FHDW670	5.4	150.00
5.6	30,000	Slide	3.75	1/4	100% Sealed Ball	Die-cast Aluminum	Unique Micro-set Depth Adjustment for Pinpoint Accuracy in Seconds, Spindle Lock for Fast Bit Changes, AC/DC Power Source	P/C	FHPC7310	4.9	120.95
5.7	35,000	Flip	3.2	1/4		Aluminum	1.0 HP, Fast & Precise Depth Adjustment, Finger Support Pockets, Spindle Lock, Constant Response™	Bosch	FHPR10E	5.0	94.95

LAMINATE TRIMMER ACCESSORIES

Description	Application	Model	Shpg. Wt.	\$ Each
1/2" Drop-in Style Collet	For use with all current	FH42950	0.1	13.67
Corner Chisel	P/C models	FH42234	0.4	22.17
1/4" Drop-in Style Collet	For use with FHPC7319 & FHPC7310	FH43002	0.1	12.81
Seaming Base	Laminate Seaming Base	FHDW6708	0.5	38.98



PLANERS



FHDW680K

3 1/4" PLANER

Shoe is precision machined on sides and bottom to deliver perfectly flat cuts and square rabbets. Quickly removes surface stock from wood to assure a level surface. Calibrated, rubber-coated height adjustment knob is easy to grasp and comfortable to use.

- ◆ Poly V-belt
- ◆ Kick stand for safety
- ◆ Accepts both carbide and steel blades



FH1594K

3 1/4" PLANER WITH CARRYING CASE

- ◆ Features versatile 2-blade system equipped with Bosch Woodrazor™ micrograin carbide blades
- ◆ Can be converted for use with large high-speed steel blades (optional accessories required).

REPLACEMENT BLADES



Description	Model	Shpg. Wt.	\$ Each
Carbide Replacement Blades, 1 Pair for FHDW680K	FHDW6654	0.1	16.23
High Speed Steel Replacement Blades, 5 Pack for FHDW680K	FHDW6655	0.1	24.37

Call FHS for FH1594K replacement blades.

No Load RPM	Amps @ 120V	Tool Weight	Depth of Cut	Width	Tool Length (in.)	Includes	Brand	Model	Shpg. Wt.	\$ Each
15,000	7	9.5	3/32	3 1/4	12 1/2	Poly V-belt, Kick Stand for Safety, Accepts Both Carbide and Steel Blades	DeWalt	FHDW680K	16.8	171.95
16,500	6.5	6	3/32	3 1/4	11 1/8	2 Woodrazor™ Blades, Chip Bag, Bevel Guide Fence, Blade Wrench & Carrying Case	Bosch	FH1594K	14.0	149.95



FHPC557

DELUXE PLATE JOINER KIT

Fence tilts from 0 Degree to 135 Degree with positive adjustable stop at 90 Degree.

Features special knob for precise micro height adjustments. Bale handle is attached to fence, not motor, for greater stability and added control during cuts. Seven-position rotating depth stop for FF, #0, #10, #20, Simplex, Duplex, and Max (#6) biscuits.

- ◆ Lock-on trigger
- ◆ Height scale is accurate at any angle
- ◆ Spindle lock for easy blade changes
- ◆ 1" O.D. dust port accepts standard bag or connects to a vacuum



FHDW682

HEAVY-DUTY PLATE JOINER KIT

- ◆ Dual rack and pinion fence ensures blade and fence are always parallel for accurate joints every time
- ◆ Integral one-piece fence is adjustable and tilts 0-90°
- ◆ Flush cuts can be made at 0° without removing fence
- ◆ 45° locating notch in fence allows indexing off the outside surface of a mitered joint
- ◆ Non-marring, heavy-duty aluminum shoe allows joiner to be clamped for stationary work
- ◆ Retractable, anti-slip pins help hold work in place
- ◆ Preset depth stops for all common biscuit sizes

PLATE JOINING BISCUITS



Made from compressed beech wood, these plate joining biscuits swell when they absorb water-based glues, further strengthening a wood joint. At 5/32-inch thick, they will fit slots cut by all standard plate joiners. **Box of 1,000**

Type	Size (mm)	Model	Shpg. Wt.	\$ Each
0	16 x 47	FHPOR5551	5.0	39.90
10	20 x 52	FHPOR5552	5.0	39.90
20	24 x 58	FHPOR5553	5.0	39.90
Assorted		FHPOR5554	5.0	39.90

* Smaller Quantities Available

No Load RPM	Amps @ 120V	Tool Weight	Depth of Cut	Tilting Angle	Tool Length (in.)	Includes	Brand	Model	Shpg. Wt.	\$ Each
10,000	7.5	7.5	3/4	0°-135°	14	Dustbag, Deflector, 2 & 4" Blade, Vacuum Adapter, Wrench, & Carry Case	P/C	FHPC557	12.25	254.95
10,000	6.5	6.6	20 mm	0°-90°	11 1/8	Carbide blade, Dust bag, Vacuum Adapter, Torx/E key, Wrench, Heavy-duty kit box	DeWalt	FHDW682	14.3	198.95

DRILLS

ELECTRIC DRILLS



FHD21002



FHD21009



FHDW140

No Load RPM	Amps @ 120V	Tool Weight (lbs.)	Gear Train	Chuck Size (in.)	Tool Length (in.)	Includes	Brand	Model	Shpg. Wt.	\$ Each
0-2,500	5.5	5.5	Single	3/8	9.6	Drill, Chuck Key	DeWalt	FHD21002	4.1	78.95
0-2,500	6.5	5.5	Single	3/8	9.6	Metal Keyless Chuck	DeWalt	FHD21009	4.1	78.95
600	7.0	7	Triple	1/2	15 1/4	Drill, AC/DC Switch, D-Handle and 3-Position Side Handle	DeWalt	FHDW140	8.35	191.95

ANGLE DRILLS



FHDW965K-2



FHDW966K-2



FHDW960K-2

Volt	Chuck Size (in.)	Drill Speed (RPM)	Tool Length (in.)	Tool Weight (lbs.)	Handle Type	Includes	Brand	Model	Shpg. Wt.	\$ Each
12	3/8	0-400, 0-1,200	12.4	4.1	Straight R.A.	2 Battery Packs, Charger, Carry Case	DeWalt	FHDW965K-2	8.6	218.95
14.4	3/8	0-400, 1,250	12.4	4.4	Straight R.A.	2 Battery Packs, Charger, Carry Case	DeWalt	FHDW966K-2	8.2	228.95
18	3/8	0-500, 1,500	12.4	4.5	Straight R.A.	2 Batteries, Charger, Carry Case	DeWalt	FHDW960K-2	11.65	238.95

10.8V CORDLESS DRIVERS



FHPS40-2
IMPACT DRIVER



FHPS10-2



FHPS20-2

Volt	Chuck Size (in.)	Drill Speed (RPM)	Tool Length (in.)	Tool Weight (lbs.)	Handle Type	Includes	Brand	Model	Shpg. Wt.	\$ Each
10.8	1/4	0-1,800	12.0	4.4	T- Grip	Trigger Switch and LED Light, 1 Lithion 10.8 VDC Battery; (2) Drive Bits, Carrying Case, 30 Minute Charger	Bosch	FHPS40-2	5.4	220.95
10.8	1/4	0-600	10.0	2.4	Straight	90 ° Articulating Head, (2) 1 1/2" Power Drive Bits, 30 Min. Charger, 2 Batteries, and Carry Case	Bosch	FHPS10-2	5.4	157.95
10.8	1/4	0-400	6 1/2	1.8	Straight	(2) 1 1/2" Power Drive Bits, 30 Min. Charger, 2 Batteries, and Carry Case	Bosch	FHPS20-2	4.7	135.95

CORDLESS DRILLS



FHDC940KA



FHDC930KA



FH33614-2G



FHDC920KA



FH33618-2G

Volts	Chuck Size (in.)	Drill Speed (RPM)	Max Torque (in./lbs.)	Clutch Style	Weight (lbs.)	Tool Length (in.)	Includes	Brand	Model	Shpg. Wt.	\$ Each
12	1/2	1-1,800	290	Adj.	5.0	9 1/4	1 Hour 120V Charger, 2 Battery Packs, and Carrying Case	DeWalt	FHDC940KA	11.75	188.95
14.4	1/2	0-1,800	335	Adj.	5.5	9 1/4	1 Hour 120V Charger, 2 Battery Packs, and Carrying Case	DeWalt	FHDC930KA	12.65	208.95
14.4	1/2	0-1,500	500	Adj.	5.3	10 1/2	2 Batteries, Charger, Belt Hook, and Carry Case	Bosch	FH33614-2G	14.1	191.95
18	1/2	0-2,000	510	Adj.	6.0	9 1/4	1 Hour 120V Charger, 2 Battery Packs, and Carrying Case	DeWalt	FHDC920KA	13.9	278.95
18	1/2	0-1,500	550	Adj.	5.7	10 1/2	2 Batteries, Charger, Belt Hook, and Carry Case	Bosch	FH33618-2G	16.1	251.95

HAMMER DRILLS



FHDC935KA



FHDC936KA



FH13618-2G



FHDC900KL

Volts	Chuck Size (in.)	Drill Speed (RPM)	Blows per Minute	Handle Type	Weight (lbs.)	Includes	Brand	Model	Shpg. Wt.	\$ Each
14.4	1/2	0-450/1450/1800	0-7650/24,560/30,000	T	6.0	2 Batteries, 1 Hour Charger, and Carry Case	DeWalt	FHDC935KA	12.8	253.95
14.4	1/2	0-450/1450/1800	0-7650/24,560/30,000	Pistol	6.0	2 Batteries, 1 Hour Charger, and Carry Case	DeWalt	FHDC936KA	13.3	253.95
18	1/2	0-450/1500/2000	0-7650/25,500/34,000	T	6.0	2 Batteries, 1 Hour Charger, and Carry Case	DeWalt	FHDC925KA	14.1	298.95
18	1/2	0-450/1500/2000	0-7650/25,500/34,000	Pistol	6.0	2 Batteries, 1 Hour Charger, and Carry Case	DeWalt	FHDC926KA	14.2	298.95
18	1/2	0-450/0-1500	0-18,000	T	6.7	2 Batteries, Charger, Belt Hook, Side Handle, and Carry Case	BOSCH	FH13618-2G	16.6	273.95
36	1/2	0-450/1200/1600	0-7650/20,400/27,200	T	6.9	1 Battery, 1Hr. Charger, Side Handle, and Carrying Case	DeWalt	FHDC900KL	17.6	458.95

SANDERS

ORBITAL SANDERS



FHPC7335



FHD26451K

REPLACEMENT PADS FOR ORBITAL SANDERS



For Use With	Desc.	Model	Shpg. Wt.	\$ Each
FHPC7335	Adhesive	FHPOR13700	0.1	28.71
FHD26451K	Adhesive	FHDW4385	0.1	28.80
FHD26451K	Hook & Loop	FHDW4388	0.1	20.91

Amps @ 120V	Orbits per Min.	Pad Size	Type of Sandpaper	Cord	Tool Weight (lbs.)	Tool Length (in.)	Features	Brand	Model	Shpg. Wt.	\$ Each
3.7	2500-6000	5	PSA	10-Ft. 2-Cond.	5.5	11.0	Side Handle, 5" Backing Pad, Assorted Discs, Wrench, Dust-sealed Switch and Ball and Roller Bearings	P/C	FHPC7335	6.5	159.95
3.0	12,000	5	Hook & Loop, 8-Hole	8-Ft. 2-Cond.	3.4	11.0	3/32" Orbit, Pad Control Prevents Pad Spin Up, 1 1/2" Shop Vacuum Adapter, Dust Bag and Carrying Case	DeWalt	FHD26451K	6.8	73.95

SANDING DISCS FOR ORBITAL SANDERS

- ◆ Resin coated to resist heat and humidity for longer life
- ◆ Made with aluminum oxide grain

Application: Wood, metal, fiberglass, plastic & painted surfaces
Fits: DA, random orbit and other back-up pads

5" FIVE-HOLE, HOOK & LOOP

Grit	Pack Qty.	Model	Shpg. Wt.	\$ Each
40	12	FH20001	0.1	9.91
60	15	FH20002	0.1	9.91
80	15	FH20003	0.1	9.91
100	15	FH20004	0.1	9.91
120	15	FH20005	0.1	9.91
150	15	FH20006	0.1	9.91
220	15	FH20007	0.1	9.91



FH20008



FH20022



FH20001



FH20036

5" AND 6" NO-HOLE, ADHESIVE-BACKED

Grit	Pack Qty.	Model	Shpg. Wt.	\$ Each
5" No-Hole, Adhesive-Backed Sanding Discs				
40	12	FH20008	0.1	8.32
60	15	FH20009	0.1	8.32
80	15	FH20010	0.1	8.32
100	15	FH20011	0.1	8.32
120	15	FH20012	0.1	8.32
150	15	FH20013	0.1	8.32
220	15	FH20014	0.1	8.32
6" No-Hole, Adhesive-Backed Sanding Discs				
40	12	FH20015	0.1	11.21
60	15	FH20016	0.1	11.21
80	15	FH20017	0.1	11.21
100	15	FH20018	0.1	11.21
120	15	FH20019	0.1	11.21
150	15	FH20020	0.1	11.21
220	15	FH20021	0.1	11.21

5" FIVE-HOLE AND 6" SIX-HOLE, ADHESIVE-BACKED

Grit	Pack Qty.	Model	Shpg. Wt.	\$ Each
5" Five-Hole, Adhesive-Backed Sanding Discs				
40	12	FH20022	0.1	8.32
60	15	FH20023	0.1	8.32
80	15	FH20024	0.1	8.32
100	15	FH20025	0.1	8.32
120	15	FH20026	0.1	8.32
150	15	FH20027	0.1	8.32
220	15	FH20028	0.1	8.32
6" Six-Hole, Adhesive-Backed Sanding Discs				
40	12	FH20029	0.1	11.21
60	15	FH20030	0.1	11.21
80	15	FH20031	0.1	11.21
100	15	FH20032	0.1	11.21
120	15	FH20033	0.1	11.21
150	15	FH20034	0.1	11.21
220	15	FH20035	0.1	11.21

5" EIGHT-HOLE AND 6" SIX-HOLE, HOOK AND LOOP

Grit	Pack Qty.	Model	Shpg. Wt.	\$ Each
5" - Eight-Hole				
40	12	FH20036	0.1	9.91
60	15	FH20037	0.1	9.91
80	15	FH20038	0.1	9.91
100	15	FH20039	0.1	9.91
120	15	FH20040	0.1	9.91
150	15	FH20041	0.1	9.91
220	15	FH20042	0.1	9.91
6" - Six-Hole				
40	12	FH20043	0.1	13.23
60	15	FH20044	0.1	13.23
80	15	FH20045	0.1	13.23
100	15	FH20046	0.1	13.23
120	15	FH20047	0.1	13.23
150	15	FH20048	0.1	13.23
220	15	FH20049	0.1	13.23

FINISHING SANDERS



FH1297DK



FHPC330

Amps @ 120V	Orbits per Min.	Pad Size (in.)	Type of Sandpaper	Cord	Tool Weight (lbs.)	Tool Length (in.)	Features	Brand	Model	Shpg. Wt.	\$ Each
2	12,000	4-1/2 x 4	1/4 Sheet	8-Ft.	4.0	10.0	Punchplate, 1 Sandpaper Sheet, Versatile carrying bag, Microfilter Dust Canister	Bosch	FH1297DK	5.0	59.95
1.2	14,000	4 1/8 x 4 1/2	1/4 Sheet	7-Ft. 2-Cond.	4.0	4.5	Palm Grip, Double Insulated, Dust-sealed Switch and Ball and Roller Bearings	P/C	FHPC330	4.4	99.95

REPLACEMENT PADS FOR FINISHING SANDERS



For Use With	Desc.	Model	Shpg. Wt.	\$ Each
FHPC330	Adhesive	FH13597	0.1	7.01
FHPC330	Hook & Loop	FH13596	0.1	22.41

CLAMP-ON SANDING SHEETS FOR FINISH SANDERS

- ◆ Resin coated to resist heat and humidity for longer life
- ◆ Made with aluminum oxide grain

Application: Wood, metal, fiberglass, plastic and painted surfaces

Fits: Finish sanders, palm sanding blocks



Grit	Pack Qty.	Model	Shpg. Wt.	\$ Each
9" x 11" Cut to Fit Sanding Sheets				
60	8	FH20300	0.5	6.12
100	10	FH20301	0.5	6.12
150	10	FH20302	0.5	6.12
220	10	FH20303	0.5	6.12
Asrt.	10	FH20304	0.5	6.12

MULTI-PURPOSE SANDING BELTS

- ◆ Bi-directional flush joint runs smoothly in both directions
- ◆ Made with heavy-duty, X-weight cloth
- ◆ Double resin system resists heat and humidity
- ◆ Made with aluminum oxide grain



Grit	Pack Qty.	Model	Shpg. Wt.	\$ Each
3" x 18" Multi-Purpose Sanding Belts				
40	4	FH20400	0.1	10.77
50	5	FH20401	0.1	10.77
80	5	FH20402	0.1	10.77
120	5	FH20403	0.1	10.77
3" x 21" Multi-Purpose Sanding Belts				
40	4	FH20404	0.1	11.27
50	5	FH20405	0.1	11.27
80	5	FH20406	0.1	11.27
120	5	FH20407	0.1	11.27
3" x 24" Multi-Purpose Sanding Belts				
40	4	FH20408	0.1	12.85
50	5	FH20409	0.1	12.85
80	5	FH20410	0.1	12.85
120	5	FH20411	0.1	12.85
4" x 24" Multi-Purpose Sanding Belts				
40	4	FH20412	0.1	17.14
50	5	FH20413	0.1	17.14
80	5	FH20414	0.1	17.14
120	5	FH20415	0.1	17.14

BELT SANDERS



FH1274DVS



FH352VS



FHDW432



FHPC361



FHPC360



FH1276DVS

Amps @ 120V	No Load SFPM	Belt Size (in.)	Tool Weight (lbs.)	Tool Length (in.)	Features	Brand	Model	Shpg. Wt.	\$ Each
6.6	550-1100	3 x 21	7.1	13.8	Variable Speed Dial, Lever Belt release, Belt Tracking Adjustment Knob, Compact Design	Bosch	FH1274DVS	9.0	198.95
8	850-1350	3 x 21	10.8	11.8	Variable Speed Dial, Sanding Belt, Gear and Belt Drive and Flush Sand Capability	P/C	FH352VS	12.5	188.95
8	1400	3 x 21	12	14	Gear, Belt Drive, Flush Sand Capability, Convenient Lever Belt Release	DeWalt	FHDW432	14.0	188.95
12	1500	3 x 24	13.7	14.0	Finger Tip Tracking, Quick Release Sanding Belt, Gear & Belt Drive, Flush Sand Capability	P/C	FHPC361	16.4	278.95
12	1500	3 x 24	14.5	14.0	Finger Tip Tracking, Quick Release Sanding Belt, Gear & Belt Drive, Flush Sand Capability	P/C	FHPC360	15.6	294.95
12.5	1150-1550	4 x 24	13.5	13.8	Rugged Design, Variable Speed Dial, Lever Belt release, Belt Tracking Adjustment Knob	Bosch	FH1276DVS	15.0	298.95

CORDLESS AND CORDED VACUUM CLEANERS

CORDLESS/CORDED VACUUM CLEANER

Allows you to operate using a 12.0 - 18V DeWalt battery or 120VAC.

Compact, portable design for easy carrying. With on-board storage for 2 accessories. Drain port for standard garden hose and hose storage. Durable vacuum has heavy-duty rubber hose, heavy-duty latches, an industrial grade switch, and a positive-lock, expandable rubber hose.

Battery and charger not included. Order separately. Uses: Has the suction power to pick up job site debris such as screws, staples, nails, sawdust, water, drywall dust, concrete dust, etc.



Tank Size (Gal)	Tank Orifice (in.)	Static Pressure (in.)	Amps @ 120V	Length (in.)	Power Cord (ft.)	Model	Shpg. Wt.	\$ Each
2	1 1/4	60	1.6	16	6	FHDC500	12.3	108.95

18V CORDLESS WET/DRY VACUUM CLEANER

Powerful, portable vacuum with 5-ft. long, 1 1/4" dia. rubber hose features industrial grade latches and switch with positive lock canister lid.

Includes 1-hour, 120V charger; 1 battery and HEPA filter.



Tank Size (Gal)	Tank Orifice (in.)	Model	Shpg. Wt.	\$ Each
1/2	1 1/4	FHDC515K	7.9	144.95

HEPA FILTERS

Trap 99.97% of dust as small as 0.3 microns. Washable and reusable.

Desc.	Model	Shpg. Wt.	\$ Each
Filters for Use with FHDC500			
Wet/Dry	FHDC5001	0.7	28.15
HEPA	FHDC5001H	0.8	37.10
Filters for Use with FHDC515K			
HEPA	FHDC5151	0.2	25.20



FHDC5001



FHDC5151

FLASHLIGHTS AND FLOODLIGHTS FOR CORDLESS TOOLS

Does Not include Battery or Charger



FLASHLIGHT
12,14.4, 18V



FLUORESCENT
12,14.4, 18V



FLOODLIGHT
14.4, 18, 36V



REPLACEMENT BULBS

2 Bulbs per package.

Description	Volts	Brand	Model	Shpg. Wt.	\$ Each
Flashlight	12	DeWalt	FHDW904	0.7	29.25
Fluorescent Light	12/14	DeWalt	FHDC528	1.7	54.50
Flashlight	14.4	DeWalt	FHDW906	0.7	29.05
Floodlight	14.4	DeWalt	FHDW918	1.3	43.40
Flashlight	18	DeWalt	FHDW908	0.8	31.60
Floodlight	18	DeWalt	FHDW919	1.3	47.75
Fluorescent Light	18	DeWalt	FHDC527	3.0	52.50
Floodlight	36	DeWalt	FHDC509	1.5	66.35

Volt	Model	Shpg. Wt.	\$ Each
For Use with FHDW904			
12	FHDW9043	0.1	6.55
For Use with FHDW906			
14.4	FHDW9063	0.1	7.52
For Use with FHDW919			
18	FHDW9083	0.1	8.74
For Use with FHDC528 & FHDC27			
12/14.4/18	FHDC5273	0.1	8.43

BATTERY PACKS



FHBAT411



FHDC9071



FHDC9091



FHBAT140



FHDC9096



FHBAT181



FHDC9360

Volts	For Use With	Battery Capacity (AH)	Brand	Model	Shpg. Wt.	\$ Each
10.8	Bosch Litheon® Pocket Drivers	1.3	Bosch	FHBAT411	0.5	46.40
12	All DeWalt 12.0 V Tools and Accessories	2.4	DeWalt	FHDC9071	1.6	67.35
14.4	All DeWalt 14.4 V Tools and Accessories	2.4	DeWalt	FHDC9091	2.1	75.00
14.4	Bosch 14.4 VDC Tools and Accessories	2.0	BOSCH	FHBAT140	2.05	76.25
18	All DeWalt 18.0 V Tools and Accessories	2.4	DeWalt	FHDC9096	2.5	89.95
18	Bosch 18.0 VDC Tools and Accessories	2.4	BOSCH	FHBAT181	2.6	94.85
36	All DeWalt 36V Lithium Ion Tools & Accessories		DeWalt	FHDC9360	2.6	176.75

UNIVERSAL PRO BATTERY CHARGER

Universal charger uses patented adapters to charge "ALL" major power tool brands. The all-new Pro Charger from 10C is capable of recharging power tools far more quickly and efficiently than any battery charger available on the market today. Users can charge most major brand batteries in 15 minutes or less (Ni-CD), 40 minutes or less (Ni-MH) and 1 hour or less (Li-Ion) and enjoy a significant increase in total battery life. **FH10007** is a REMOTE charger—no AC needed; rechargeable lead-acid battery inside the charger.

FH10006



FH10007



Desc.	Model	Shpg. Wt.	\$ Each
Universal Pro Charger	FH10006	6.0	179.99
REMOTE Universal Pro Charger	FH10007	8.0	279.99
Charger Adapters—sold separately			
Bosch 12V-18V	FH10008	0.1	24.99
DeWalt 12V-18V	FH10009	0.1	24.99
Makita 12V-18V	FH10010	0.1	24.99
Milwaukee 12V-18V	FH10011	0.1	24.99

CHARGERS

FHBC430



FHDW9116



FHDC9000



FHDW9109



FHDW9117



FHDW9216



FHBC130



FHDC011



FHPB10-CD



Volts	Description	Brand	Model	Shpg. Wt.	\$ Each
10.8	30-min. Charge Time, for Bosch Litheon® Pocket Drivers	Bosch	FHBC430	1.3	60.80
7.2-18.0	1-Hour Charger for DeWalt Batteries	DeWalt	FHDW9116	1.12	57.35
36.0	Charges DeWalt 36 V Lithium Ion Batteries	DeWalt	FHDC9000	2.3	101.00
7.2-18.0	Vehicle Charger, 1-Hour	DeWalt	FHDW9109	1.5	89.85
7.2-18.0	15 Minute Quick Charger 120 AC	DeWalt	FHDW9117	2.0	138.65
7.2-18.0	2-Port Charger	DeWalt	FHDW9216	2.2	100.95
9.6-24.0	30-min. Charge Time, Charge indicator w/ 2 LED's	Bosch	FHBC130	2.0	76.25
7.2-18.0	Charger/Radio 120AC	DeWalt	FHDC011	16.4	144.00
12.0-24.0	Job Site Battery Charger/Radio, CD Player 1-hr. Charge Time, 12VDC Outlet	Bosch	FHPB10-CD	24.3	200.00

ROTARY SCREW AIR COMPRESSORS

Sound enclosure allows for extremely quiet operation with noise levels as low as 65 dBA.

Space-saving, prewired, tank-mounted design allows work in smaller areas or close to walls. Panel access to internal components for quick, easy service. Automatic belt tensioning system and air end bearings protect against over tension, under tension, and slippage for longer life. Ultra Plus 9000 Hour synthetic lubricant and 2-stage separator system reduce wear and provide superior cooling characteristics at a fully loaded, 100% continuous-duty cycle. Oil carryover is less than 3 ppm. Suitable for use in ambient temperatures to 104°F.



ROTARY SCREW MAINTENANCE KITS



For Use With	Model	Shpg. Wt.	\$ Each
5-7.5 or 10-15 HP	FH30112	23.0	269.75
20-30 HP	FH30113	23.0	339.00

HP	Delivery (CFM)	Voltage	Phase	Amps AC	Receiver	(F)NPT Outlet	dBA @ 3 FT	Length (in.)	Depth (in.)	Height (in.)	Model	Shpg. Wt.	\$ Each
15	55	200	3	43.2	120 Gal	3/4	69	75	29	61	FH30101	650.0	6,749.00
15	55	230	3	37.6	120 Gal	3/4	68	75	29	61	FH30102	650.0	6,749.00
15	55	460	3	18.8	120 Gal	3/4	69	75	29	61	FH30103	650.0	6,749.00
20	83	230/460	3	56.4/28.2	120 Gal	1	68	77.5	36	71	FH30104	1510.0	9,459.00
25	102	200	3	76.6	120 Gal	1	69	77.5	36	71	FH30105	1510.0	9,869.00
25	102	230/460	3	66.6/33.3	120 Gal	1	69	77.5	36	71	FH30106	1510.0	9,869.00
30	125	200	3	91.3	120 Gal	1	69	77.5	36	71	FH30107	1510.0	10,679.00
30	125	230/460	3	79.3/39.7	120 Gal	1	69	77.5	36	71	FH30108	1510.0	10,679.00

Rotary Screw Compressor with Dryer and Filtration Package

15	50	200	3	13.0	120 Gal	3/4	69	75	29	61	FH30109	1035.0	8,839.00
15	50	230	3	43.2	120 Gal	3/4	69	75	29	61	FH30110	1035.0	8,839.00
15	50	460	3	37.6	120 Gal	3/4	69	75	29	61	FH30111	1035.0	8,839.00

TYPE-30 TWO-STAGE AIR COMPRESSORS

100% cast-iron compressors are durable and reliable performers. They feature totally enclosed belt guard and reliable splash lubrication. 5-7.5 HP models have automatic Start/Stop control. 10-HP vertical models have automatic Start/Stop control and oil sight glass. Tough, baked-on powder coat beige enamel finish.

- ◆ Compressors have Ingersoll Rand 2-year limited pump warranty.
- ◆ Expected pump life of 15,000 hours
- ◆ 100% continuous duty
- ◆ NEMA 1 starter on most units
- ◆ ASME tank with manual drain and discharge isolation valve
- ◆ Comply with State of California Code 462(L)(2)



AIR COMPRESSOR START-UP KITS

Include All Season Select® lubricant, two inlet air filters, and product data sheet.



For Use On	Model	Shpg. Wt.	\$ Each
5-7.5 HP	FH30209	10.2	89.60
10-15 HP	FH30210	10.2	92.50

HP	Free Air CFM @175 PSI	Volts	Phase	Full Load Amps	Oil Capacity (Oz.)	Tank (Gal)	(F)NPT Outlet	Length (in.)	Width (in.)	Height (in.)	Model	Shpg. Wt.	\$ Each
5	15	230	1	28	32	80V	1/2	32	24	67	FH30200	475.0	1,399.00
5	15	230/460	3	15.3	32	80V	1/2	32	24	67	FH30201	475.0	1,399.00
5	15	200	3	15.2/7.6	32	80V	1/2	32	24	67	FH30202	475.0	1,399.00
7.5	24	230	1	40	43	80V	3/4	37	28	70	FH30203	600.0	1,909.00
7.5	24	200	3	25.3	43	80V	3/4	37	28	70	FH30204	561.0	1,909.00
7.5	24	230/460	3	22/11	43	80V	3/4	37	28	70	FH30205	550.0	1,909.00
10	35	200	3	31	74	120V	3/4	44	32	82	FH30206	1200.0	2,459.00
10	35	230	3	27	74	120V	3/4	44	32	82	FH30207	1200.0	2,459.00
10	35	460	3	13.3	74	120V	3/4	44	32	82	FH30208	935.0	2,459.00

REFRIGERATED COMPRESSED AIR DRYERS

Cool compressed air and remove harmful moisture. Water vapor condenses and is removed from air stream by a moisture separator. Unique design improves efficiency which saves energy and minimizes downtime.



Max HP	Capacity Pressure 35°F	(SCFM) @ Dew Point 50°F	Volts	Amp Draw	Inlet/Outlet Conn. (in.)	Height (in.)	Width (in.)	Depth (in.)	Refrigerant	Model	Shpg. Wt.	\$ Each
5	15	19	115	3.2	3/8	18	8	18	R134A	FH30250	49.9	729.00
7.5	25	31	115	4.2	1/2	21	12	24	R134A	FH30251	77.5	1,009.00
10	35	44	115	5.6	1/2	21	12	24	R134A	FH30252	75.0	1,289.00
15	50	62	115	7.4	3/4	24	14	28	R134A	FH30253	110.0	1,639.00
20	75	93	115	9.6	3/4	24	14	28	R134A	FH30254	125.0	2,139.00
25	100	125	115	10.1	1½	31	22	24	R407C	FH30255	148.0	2,439.00
30	150	187	208/230	8.5	1½	31	22	24	R407C	FH30256	151.0	3,129.00

PORTABLE AIR COMPRESSORS

PORTER CABLE

Regulated air pressure gauge with a high-flow air regulator and push-to-connect coupler. The 4-pole, 1725 RPM induction motor operates at only 80 dB - up to 50% quieter than most 2-pole models. Fold down cushioned handle.

DEWALT

Feature high-output, oil-lubricated, direct-drive pumps with cast-iron cylinders for reliability. Dual soft start valves that assist in cold weather startup. Ball valve drain.



Oil Lub.	Tank Type	Max Pressure (PSI)	Free Air CFM @ 90 PSI	Volts	Tank (Gal)	Length (in.)	Width (in.)	Height (in.)	Brand	Model	Shpg. Wt.	\$ Each
	Pancake	1.2	3.3	120	4	19 1/8	18 3/8	26 1/2	P/C	FHPC2150	65.4	289.00
X	Single	1.2	4.6	115	4	21 3/4	16	12 1/2	DEWALT	FHD55155	67.0	369.00
X	Twin-Stack	1.2	4.6	115	4	18	15	16	DEWALT	FHD55153	65.3	329.00
	Cart-Mounted Single	1.6	6.0	120	4.5	29 1/2	24	16 1/2	P/C	FHPC3151	92.0	339.00

PORTABLE WHEELBARROW AIR COMPRESSORS

DEWALT ELECTRIC COMPRESSOR

Electric motor is ideal for an enclosed area where gas fumes are unacceptable. Features include regulator cluster, 2 pole induction thermal overload-protected motor, ball valve drain, On/Off constant run design for reduced breaker tripping, and a semipneumatic tire.

INGERSOLL RAND GAS COMPRESSOR

Ideal for applications where electricity is not available. 100% continuous duty cast-iron pump provides maximum operating pressures. Includes air regulator, gauge, and 2 quick disconnects to power multiple air tools.



Type	HP	Max Pressure (PSI)	Free Air CFM @ 90 PSI	Volts, 60 Hz	Amp Draw	Tank (Gal)	(F)NPT Outlet	Length (in.)	Width (in.)	Height (in.)	Brand	Model	Shpg. Wt.	\$ Each
Electric	1.5	125	6.7	115	15.2	8	3/8	43	18 1/4	23 1/2	DEWALT	FHD55170	221.0	659.00
Gas	5.5	135	11.8	—	—	8	3/8	44	18	26	IR	FHSS3J5	198.0	929.00

PORTABLE BARREL AIR COMPRESSORS

DEWALT ELECTRIC COMPRESSOR

High-pressure unit provides 500 hours of pump life from its oil-free pump. Operating noise level stays at a low 82 dBA. Features recessed control panel, roll-cage protection, ball drain valve, and air hose storage.

DEWALT GAS-POWERED COMPRESSOR

Recessed control panel, roll cage, ball valve drain, and low-oil pressure switch. Durable composite molded belt guard. Dual 12" tires. 3.6" ground clearance.



Type	HP	Max Pressure (PSI)	Free Air CFM @ 90 PSI	Volts, 60 Hz	Amp Draw	Tank (Gal)	(F)NPT Outlet	Length (in.)	Width (in.)	Height (in.)	Brand	Model	Shpg. Wt.	\$ Each
Electric	1.9	200	5.4	120	16.0	15	1/4	21 1/8	18 7/8	41 5/8	DEWALT	FHD55168	97.0	429.00
Gas, 1 Stage	5.5	150	10.3	—	—	10.5	3/8	46 1/2	25 1/2	31 3/4	DEWALT	FHD55273	247.0	1,109.00

BRAD NAILER KITS

18-GAUGE BRAD NAILER KIT

Ergonomic lightweight design has oil-free, no jam magazine, rear exhaust, depth control and no mar tip. Narrow nose for hard to reach areas. Kit includes carrying case, 1000 fasteners and 1/4" air fitting. Max PSI 100.



Fastener Range (in.)	CFM Per Shot	Tool Wt. (lbs.)	Brand	Model	Shpg. Wt.	\$ Each
5/8-2	0.016	2.6	Bostitch	FHB200K-1	5.8	105.95
Slight Head 5/8 - 1, Medium Head 1 - 1 5/8		2.3	Senco	FHSLP20	5.0	174.00

18 GAUGE BRAD NAILER

The FHSLP20 Brad Nailer drives both slight-headed and medium-headed brads in a wide range of lengths. As the result of extensive customer research, the FHSLP20 design ensures unmatched ease of use as well as superior precision and driving power, which makes the tool suitable for fastening a variety of material types and thicknesses.



18-GAUGE BRADS

3,000 per package.



Shank	Length (in.)	Model	Shpg. Wt.	\$ Each
Bright Brown Heads	5/8	FH31000	0.9	7.74
Bright Brown Heads	3/4	FH31001	1.3	8.50
Bright Brown Heads	1	FH31002	1.5	9.05
Bright Brown Heads	1 3/8	FH31003	2.1	10.08
Galvanized Brown Heads	1 3/4	FH31004	1.8	13.10
Galvanized Brown Heads	2	FH31005	2.0	14.38

*SENCO® Fasteners Available Contact FHS Representative

STAPLERS

1/2" CROWN STAPLER

Adjustable depth control; easy, clear front nose; and directional exhaust deflector. Molded comfort grip. Powerful, yet lightweight and easy to handle in high-volume applications.



NARROW CROWN STAPLER KIT

Quick-load, high-capacity magazine, and quick cycling simplified valve system. Rear exhaust; narrow nose for tight areas. Compact, lightweight and oil free. Includes a carrying case and 1000 1" staples.



MEDIUM WIRE STAPLER

The ergonomically designed FHLS20 increases quality and productivity in a wide variety of applications. The FHLS20XP stapler from SENCO® is not only lightweight, it's powerful. This popular stapler weighs just 2.5 lb. New 5-Year Warranty. Capacity 168.



HEAVY-WIRE STAPLER

The lightweight FHSNS45XP Stapler is built to last. With 30% fewer parts and 15% more power than comparable tools, it's one stapler you won't want to put down. Weighing just 5.1 pounds, it has the best power-to-weight ratio in its class. Plus, it drives staples at a rate of 15 cycles per second. New 5-Year Warranty.



MEDIUM WIRE STAPLER

The ergonomically designed FHLS25XP stapler from SENCO® is powerful and versatile. This new-generation stapler weighs just 2.7 lbs, yet has the power to drive 1-1/2" staples into hard woods. Two models drive 1/4" and 3/8" crown staples in lengths from 3/8" — 1-1/2". New 5-Year Warranty.



Contact Full House for more Senco Items.



STAPLES

Gauge Dia.	Length (in.)	Box Qty.	Model	Shpg. Wt.	\$ Each
1/2" Galvanized Crown Staples					
16	1 1/2	14,250	FH31006	38.8	76.05
16	1 3/4	11,400	FH31007	36.0	66.35
16	2	11,400	FH31008	39.3	70.15
7/32" Galvanized Narrow Crown Staples					
0.05 x 0.035	1/2	5,000	FH31009	2.4	17.29
0.05 x 0.035	3/4	5,000	FH31010	3.6	18.31
0.05 x 0.035	1	5,000	FH31011	4.6	19.33
0.05 x 0.035	1 1/4	3,000	FH31012	3.5	15.25
0.05 x 0.035	1 3/8	3,000	FH31013	2.0	17.29

*SENCO® Fasteners Available Contact FHS Representative

Fasteners Range (in.)	Crown (in.)	Max PSI	Tool Wt. (lbs.)	Brand	Model	Shpg. Wt.	\$ Each
1/2" Crown Stapler							
1-2	1/2	100	5.3	Bostitch	FH650S4-1	6.7	426.95
1-2	7/16	120	5.1	Senco	FHSNS45XP	6.5	318.00
Narrow Crown Stapler Kit							
1/2-1 1/2	7/32	100	2.5	Bostitch	FHSX150K-1	5.9	120.95
3/8-1 1/2	3/16, 1/4 & 3/8	120	2.5	Senco	FHLS20XP	6.0	255.95
3/8-1 1/2	1/4 & 3/8	120	2.7	Senco	FHLS25XP	6.2	225.00

AIR NAILERS

FINISH NAILER

Zero nail lockout prevents damage from empty cycling. Oil-free engine. Adjustable depth of drive. Rear exhaust directs air away from user. Magnesium housing features a convenient side-load magazine and nonmarring tip.

FRAMING NAILERS

Angle magazine allows nailing in tight spaces such as toenailing and corners. Features Smart Trigger, tool-free adjustable exhaust, and push-button depth of drive.

ANGLE FINISH NAILER KIT

Jams clear easily with tool-free removable magazine. Adjustable depth control. Simple, one-step loading utilizing bypass nail pusher. Molded rubber grip. Tool-free, adjustable exhaust deflector. Kit includes no-mar tip, 1000 fasteners, and carrying case.

****Note:** Best performance achieved with manufacturer's fasteners.

Fastener Range (in.)	Gauge/Dia.	CFM Per Shot	Max PSI	Tool Wt. (lbs.)	Magazine Capacity	Model	Shpg. Wt.	\$ Each
Finish Nailer								
1-2 1/2	16	0.038	120	3.3	105	FH16250K-2	8.5	192.95
Angle Finish Nailer Kit								
1-2 1/2	15	0.04	70-120	3.8	129	FH62FNK-2	9.7	212.95
Framing Nailer								
2-3 1/2	0.113 - 0.131	0.075	120	7.7	100	FH28WW	9.8	304.95

FASTENERS

Shank	Gauge/Dia.	Length (in.)	Pkg. Qty.	Brand	Model	Shpg. Wt.	\$ Each
Straight Finishing Fasteners							
Galvanized	16	3/4	2,000	Paslode	FH31017	3.6	6.85
Galvanized	16	1 1/4	2,000	Paslode	FH31018	2.2	8.15
Galvanized	16	1 1/2	2,000	Paslode	FH31019	5.2	9.07
Galvanized	16	1 3/4	2,000	Paslode	FH31020	3.1	9.79
Galvanized	16	2	2,000	Paslode	FH31021	4.4	10.00
Galvanized	16	2 1/4	2,000	Paslode	FH31022	5.0	13.12
Galvanized	16	2 1/2	2,000	Paslode	FH31023	5.6	13.44
Angled Finishing Fasteners							
Plain Steel Coated	15	1 1/2	3,655	Bostitch	FH31024	6.8	26.85
Plain Steel Coated	15	2	3,655	Bostitch	FH31025	8.9	27.90
Plain Steel Coated	15	2 1/2	3,655	Bostitch	FH31026	11.0	30.05
Galvanized	16	1 1/4	2,000	Paslode	FH31027	2.2	11.72
Galvanized	16	1 1/2	2,000	Paslode	FH31028	2.6	12.74
Galvanized	16	1 3/4	2,000	Paslode	FH31029	3.0	15.29
Galvanized	16	2	2,000	Paslode	FH31030	3.5	16.31
Galvanized	16	2 1/2	2,000	Paslode	FH31031	4.3	17.33
Framing Fasteners							
Smooth	0.113	2	5,000	Bostitch	FH31032	30.1	60.20
Smooth Galvanized	0.113	2 3/8	5,000	Bostitch	FH31033	39.5	80.60
Ring Shank Galvanized	0.113	2 3/8	5,000	Bostitch	FH31034	38.5	80.60
Smooth	0.113	2 3/8	5,000	Bostitch	FH31035	36.7	60.20
Ring Shank	0.113	2 3/8	5,000	Bostitch	FH31036	35.1	70.40
Smooth	0.120	3	3,000	Bostitch	FH31037	30.3	50.00
Smooth	0.131	3	3,000	Bostitch	FH31038	34.2	50.00
Smooth	0.131	3 1/4	2,500	Bostitch	FH31039	31.2	45.95
Smooth Galvanized	0.131	3 1/4	2,500	Bostitch	FH31040	32.5	60.20
Smooth	0.131	3 1/2	2,500	Bostitch	FH31041	34.1	58.20



FH16250K-2



FH62FNK-2



FH28WW



FH31017

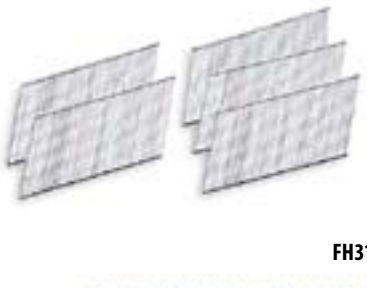

FH31024



FH31032

1/4" STRAIGHT HANDLE SCREWDRIVERS



FH7763S



FH7761



FHC782



FHC783

RPM	Hex Drive (in.)	Length (in.)	Air Inlet (in.)	Max Air Pressure	Features	Brand	Model	Shpg. Wt.	\$ Each
800	1/4	11	1/4 NPT	90 PSI	Reversible, Bail Hanger, Internally adjustable clutch, Rear Exhaust, Lightweight and easy to use, 45-145 in./lbs. Torque	Taylor	FH7763S	2.7	146.95
1600	1/4	8 7/8	1/4 NPT	90 PSI	Reversible, Accurate Torque, Internally adjustable clutch, Rear Exhaust, Max. Torque Soft Pull 30 in. lbs. , Max. Torque Hard Slam 70 in. lbs.	Taylor	FH7761	1.3	105.95
1800	1/4	9 5/8	1/4 NPT	90 PSI	External clutch adjustment, Cushion clutch, Built-in quick change chuck, Rear exhaust, Convenient forward/reverse valve 31-44 in./lbs. Torque	Chicago Pneumatic	FHC782	2.5	317.95
2000	1/4	8 7/8	1/4 NPT	90 PSI	Internal clutch adjustment, Cushion clutch, Compact design, Magnetic bit holder	Chicago Pneumatic	FHC783	1.4	311.95

1/4" CLUTCH SCREWDRIVERS



FHC781



FH7764EX



FHC780



FH7763EX



FH7763



FH7766

RPM	Hex Drive (in.)	Length	Air Inlet (in.)	Features	Brand	Model	Shpg. Wt.	\$ Each
800	1/4	8 7/8	1/4 NPT	External clutch adjustment, Cushion clutch, Built-in quick change chuck, Handle exhaust directs air away from the work piece and operator, Convenient forward/reverse valve	Chicago Pneumatic	FHC781	3.0	333.95
800	1/4	9	1/4 NPT	Reversible, Ergonomic Handle, Externally adjustable clutch, Rear exhaust, 45-145 in./lbs. Torque	Taylor	FH7764EX	3.5	280.95
1800	1/4	9 3/4	1/4 NPT	External clutch adjustment, Cushion clutch, Built-in quick change chuck, Handle exhaust directs air away from the work piece and operator, Convenient forward/reverse valve 25-44 in./lbs. Torque	Chicago Pneumatic	FHC780	3.1	323.95
1800	1/4	9	1/4 NPT	Reversible, Ergonomic Handle, Externally adjustable clutch, Rear exhaust 45-115 in./lbs. Torque	Taylor	FH7763EX	3	280.95
1800	1/4	7	1/4 NPT	Internally adjustable clutch , Reversible, Ergonomic Handle, Rear Exhaust, 45-115 in./lbs. Torque	Taylor	FH7763	2.5	138.95
1800	1/4	7	1/4 NPT	Positive clutch, Precision bearings and gears, Rear exhaust, Reversible, Lightweight, 115 in./lbs. Torque	Taylor	FH7766	2.25	128.95

3/8" STRAIGHT DRILLS



FH7701D



FHC887

RPM	Drill Chuck (in.)	Hose Size (in.)	Length (in.)	Air Inlet (in.)	Max Air Pressure	Features	Brand	Model	Shpg. Wt.	\$ Each
2500	3/8	3/8 ID	7 3/4	1/4 NPT	90 PSI	Lightweight, Easy to maneuver, Built-in regulator, Powerful motor and planetary gear system	Taylor	FH7701D	2.8	76.95
2700	3/8	3/8	8	1/4 NPT	90 PSI	Built-in regulator, Lock off throttle to prevent accidental start up, Perfect for drilling in hard to reach areas.	Chicago Pneumatic	FHC887	2.3	109.95

3/8" CLUTCH DRILLS



FHC785



FH7788



FH7788R



FHC789R-26

RPM	Drill Chuck (in.)	Length (in.)	Air Inlet (in.)	Max Air Pressure	Features	Brand	Model	Shpg. Wt.	\$ Each
2400	3/8	7	1/4 NPT	90 PSI	Power and versatile general purpose air drill, Reduced noise from handle vented exhaust, Teasing throttle provides precise control	Chicago Pneumatic	FHC785	2.3	120.95
2500	3/8	7	1/4 NPT	90 PSI	Quality hardened gears, Rear Exhaust, Variable Speed, Lightweight aluminum handle	Taylor	FH7788	2.0	59.95
2500	3/8	7	1/4 NPT	90 PSI	Reversible Drill, Quality hardened gears, Rear Exhaust, Variable Speed, Lightweight aluminum handle	Taylor	FH7788R	2.0	69.95
2600	3/8	7	1/4 NPT	90 PSI	Reversible Drill, Teasing throttle for precise control, Handle exhaust reduces noise and directs air away from operator and workplace, Needle bearing gearing for improved durability, Oil free operation	Chicago Pneumatic	FHC789R-26	3.0	229.95

DRILL CHUCKS & ACCESSORIES

3/8" DRILL CHUCK



Model	\$ Each
FH7788-A	21.00

NEW STYLE

3/8" DRILL CHUCK KEY



Model	\$ Each
FH7788S2-B	13.00

ADJUSTABLE TOOL BALANCER

Balancer includes adjustable cable stop and lower safety hook. Hand-windable spring tension adjustment knob is flush with housing. Push-button tension release simplifies decrease of spring tension. Oversized cable opening with direct in-line pull reduces cable wear.

- ◆ Cable is 270-lb. test, 0.047" diameter 7 x 7 strand galvanized steel aircraft cable.
- ◆ For Tool Weighing 3.0 to 5.0 lbs.
- ◆ Reel Weight 1.1 lbs.



Desc.	Model	Shpg. Wt.	\$ Each
Tool Balancer	FH35000	1.15	37.85

HOLSTER WITH AIR DISCONNECT

Keep your air tools within a hands reach. Easily attaches to Full House machinery. Convenient air disconnect included.



Desc.	Model	Shpg. Wt.	\$ Each
Holster	FH036500	5.0	22.45

ORBITAL PALM SANDERS

5" AND 6" PALM GRIP DA SANDERS

- ♦ Adjustable exhaust
- ♦ Heavy duty ball bearing construction
- ♦ Paddle Lever
- ♦ Light and Powerful
- ♦ Smooth cutting action
- ♦ Built in regulator



Free Speed RPM	Pad Size (in.)	Orbit Dia. (in.)	Air Inlet (in.)	Spindle Size (in.)	Max Air Pressure	Model	Shpg. Wt.	\$ Each
10,000	5	3/16	1/4 NPT	5/16 - 24	90 PSI	FH7555	2.4	119.95
10,000	6	3/16	1/4 NPT	5/16 - 24	90 PSI	FH7556	2.4	119.95

5" RANDOM ORBITAL SANDER

Lightweight 1.7 lbs for minimal operator fatigue. Lock-off lever reduces the risk of accidental start-up. 2 interchangeable "grip" sizes for easier control and added comfort. 0.3 HP highly reliable motor.



Free Speed RPM	Pad Size (in.)	Air Flow at Max Output	HP	Air Inlet (in.)	Max Air Pressure	Model	Shpg. Wt.	\$ Each
12,000	5	16.6 CFM	.3	1/4 NPT	90 PSI	FHSXRB50	2.0	225.00

6" RANDOM ORBITAL SANDER

Lightweight 1.7 lbs. for minimal operator fatigue. Lock-off lever reduces the risk of accidental start-up. 2 interchangeable "grip" sizes for easier control and added comfort. 0.3 HP highly reliable motor.



Free Speed RPM	Pad Size (in.)	Air Flow at Max Output	HP	Air Inlet (in.)	Max Air Pressure	Model	Shpg. Wt.	\$ Each
12,000	6	16.6 CFM	.3	1/4 NPT	90 PSI	FHSXRB60	2.0	225.00

JITTERBUG SANDERS

Used for wet or dry sanding. Great for fiberglass, plastic, steel, aluminum, or wood. A must for every body shop and woodworking shop.



RPM	Pad Size (in.)	Length (in.)	Air Inlet (in.)	Max Air Pressure	Features	Brand	Model	Shpg. Wt.	\$ Each
8,000	3 ² / ₃ x 9	6 ⁵ / ₈	1/4 NPT	90 PSI	Positive lock clips hold paper in place, Rubber grip absorbs shock, One hand operation	Taylor	FH7765	4.75	61.95
8,000	3 ² / ₃ x 9	8 ³ / ₄	1/4 NPT	90 PSI	Comfortable rubber grip, Pre-set regulator valve controls air pressure to assure optimum tool life, Heavy-duty ball bearing construction for durable operation	Chicago Pneumatic	FHC766	5.2	152.95

SANDER ACCESSORIES

5" DA PAD

FH7415



6" DA PAD

FH7416



Pad Size (in.)	Spindle Size (in.)	For Use W/model	Model	\$ Each
5	5/16 - 24	FH7555	FH7415	14.50
6	5/16 - 24	FH7556	FH7416	15.50

ZOOM SPOUT OILER

Flexible 7" telescoping spout makes it easy to reach difficult areas. Premium-grade, all-purpose, turbine-grade lubricating oil is for general applications.



Desc.	Model	Shpg. Wt.	\$ Each
Multi Purpose Oil	FH35010	0.3	2.35

RECIPROCATING MINI SAW

- ◆ Lightweight
- ◆ Adjustable guard for depth of cut
- ◆ Built-in regulator
- ◆ Hose Size 3/8" ID



FH7702

Small and easy to use, the T-7702 cuts straight and curved shapes. Cuts aluminum, mild steel, plastic and fiberglass with ease. Comes with two blades (24 & 32 TPI). Order extra blades in packs of 10pcs, part# T-770218(18TPI), T-770224(24TPI) or T-770232(32TPI).

Strokes per min.	Stroke (in.)	Hose Size (in.)	Length (in.)	Air Inlet (in.)	Max Air Pressure	Model	Shpg. Wt.	\$ Each
10,000	1/4	3/8 ID	7 1/8	1/4 NPT	90 PSI	FH7702	2.0	89.95

MINI SAW BLADES



Desc.	Model	\$ Each
24 TPI 6 PK	FH770224	20.35
32 TPI 6 PK	FH770232	20.35

RECIPROCATING AIR SAW

- ◆ Lock off throttle for protection against accidental start ups
- ◆ Adjustable guide offers flexibility in setting depth of cut
- ◆ Rear exhaust directs air away from the work area
- ◆ Ergonomic design for comfort and easy handling
- ◆ Low vibration to reduce operator fatigue and ensure accurate cutting



FHC881

This premium cutting tool offers exceptional value while providing increased comfort, performance and durability.

Strokes per min.	Air Inlet (in.)	Max Air Pressure	Model	Shpg. Wt.	\$ Each
10,000	1/4 NPT	90 PSI	FHC881	2.0	225.00

PALM GRIP AIR NAIL DRIVER

- ◆ Operates in any position
 - ◆ Tool stops when nail is set
 - ◆ Drives up to 60 penny nails
- Slight downward pressure activates the driving cycle.

FH7780



Nail Type	Blows per min.	Length (in.)	Air Inlet (in.)	Max Air Pressure	Model	Shpg. Wt.	\$ Each
60 penny	1,000	4 7/8	1/4 NPT	90 PSI	FH7780	2.4	140.95

PALM GRIP AIR HAMMER

Replaces mallets and hammers in close quarter situations. Installs dowel pins, screen splines and is excellent for autobody panel bumping.

T-7781



Blows per min.	Length (in.)	Air Inlet (in.)	Max Air Pressure	Model	Shpg. Wt.	\$ Each
1,000	4 1/2	1/4 NPT	90 PSI	FH7781	2.0	158.95

1/4" 90° ANGLED DIE GRINDER

Features and Benefits:

- ◆ Compact, lightweight design for easy maneuverability
 - ◆ 90° angle head allows flexibility in confined areas
 - ◆ Complete with 1/4" and 6mm collet
 - ◆ Excellent for high speed blending, smoothing, porting and deburring in confined areas
 - ◆ Lock-off throttle to prevent accidental start up
- Free speed: 22,500 rpm; average air consumption: 5.5 CFM; air inlet thread: 1/4" NPTF; minimum hose size: 3/8"; sound dBA: 101; length: 4.88"; weight: 1 lb.



Desc.	Model	Shpg. Wt.	\$ Each
Angled Die Grinder	FHC875	1.5	122.95

4" HEAVY DUTY ANGLE GRINDER

Features and Benefits:

- ◆ Powerful .6 HP high performance motor for fast, efficient grinding in tight quarters
 - ◆ Aluminum alloy housing is rugged yet lightweight for maximum operator comfort
 - ◆ Spiral bevel gearing in angle head provides extended life and smooth low vibration
 - ◆ Removable handle allows access to tight quarter work
 - ◆ Applications: weld preparation and smoothing; rust removal; deburring & blending of steel & aluminum
- Spindle size: 3/8"-24; 4" wheel size; free speed: 12,000 RPM; average air consumption: 6 CFM; air inlet thread: 1/4" NPTF; minimum hose size: 3/8"; sound dBA: 85; length: 9"; weight: 3.75 lbs.



Desc.	Model	Shpg. Wt.	\$ Each
Angle Grinder	FHC854	4.1	324.95

MULTIPURPOSE REINFORCED AIR HOSE

20% less weight per foot than comparable rubber hoses. Resists checking, cracking, and fading. If coupling, use crimped-on fittings only. Reusable fittings not recommended.

300 PSI COUPLED ASSEMBLIES

Brass couplings resist corrosion. PVC cover is reinforced with polyester yarn. PVC tube.

FH35100



FH35101



Hose Inside Dia. (in.)	Hose Length (ft.)	Fitting Size (in.)	Hose Outside Dia. (in.)	Color	Temp. Range (°F)	Safety Factor	Meets	Model	Shpg. Wt.	\$ Each
3/8	50	3/8 MNPT	0.60	Yellow	-10 to 158	4:1	RMA Class B	FH35100	5.1	24.70
3/8	25	1/4 MNPT	0.60	Black	-10 to 158	4:1	RMA Class B	FH35101	2.8	16.45
3/8	50	1/4 MNPT	0.60	Black	-10 to 158	4:1	RMA Class B	FH35102	5.3	24.70

POLYURETHANE COILED AIR HOSE

Transparent blue polyurethane hose provides excellent flexibility for automated assembly, robotics, and packaging machinery applications. Superior abrasion resistance. Will not mar or scratch surfaces. Resists kinking, oil, grease, and moisture absorption.

- ♦ Temperature range: -4° to 158°F
- ♦ Working pressure 125 psi*
- ♦ 3:1 safety factor at 75°F
- ♦ Male rigid x male swivel connections



FH35103

Hose Inside Dia. (in.)	Usable Length (ft.)	Hose Length (ft.)	NPT Size (in.)	Model	Shpg. Wt.	\$ Each
1/4	25	30	1/4	FH35103	1.0	40.00

* Based on 3:1 safety factor at 75°F. If hose is used in temperatures above 75°F it should be first tested for safety purposes in that environment. Hose burst pressure decreases significantly at higher temperatures.

NYLON COILED AIR HOSE

Nylon recoil hose has high resistance to oil, grease, and moisture absorption. Smooth, high-gloss inner and outer surface. Safety yellow color.

- ♦ Temperature range: -4° to 158°F
- ♦ Working pressure 185 psi*
- ♦ Coil spring guards on both ends
- ♦ Male rigid x male swivel connections



FH35104

Hose Inside Dia. (in.)	Usable Length (ft.)	Hose Length (ft.)	NPT Size (in.)	Model	Shpg. Wt.	\$ Each
1/4	9	12	1/4	FH35104	0.4	13.70
1/4	18	25	1/4	FH35105	0.5	16.50
3/8	8	12	3/8	FH35106	0.6	23.85
3/8	18	25	3/8	FH35107	0.7	34.00

NONMAR AIR TOOL SWIVEL FITTINGS

Lightweight, plastic-encapsulated steel body. Male end fits directly into air inlet of tool and female end connects to quick coupler or hose fitting. Maximum working pressure is 150 psi.

Note: Not for use with percussion tools.



FH35108

Inlet Thread (F)NPT (in.)	Outlet Thread (M)NPT (in.)	Model	Shpg. Wt.	\$ Each
3/8	1/4	FH35108	0.7	34.50
3/8	3/8	FH35109	0.5	34.50
1/2	1/2	FH35110	0.6	43.65

AIR TOOL SWIVEL FITTINGS

Fitting may be threaded directly into air inlet of tool or into standard quick disconnect coupler.

Uses:

For drills, screwdrivers, grinders, polishers, sanders, spray guns, and all other air operated tools



FH35111

Inlet Thread (F)NPT (in.)	Outlet Thread (M)NPT (in.)	Model	Shpg. Wt.	\$ Each
1/4	1/4	FH35111	0.2	30.50
3/8	3/8	FH35112	0.4	40.80

LIGHT INDUSTRIAL REELS

Steel reels have corrosion-resistant powder coating. Wide, L-shaped base has groove reinforcement to ensure stable support. Four-direction, non-sag rollers reduce hose wear abrasion. Spring is fully enclosed and lubricated. Multipurpose ratchet lock, easy tension adjustment, and full-flow swivel prevent leakage. Guide arm adjusts easily to permit wall, ceiling, and floor mounts.

Hose guide arm can be positioned for ceiling, wall, floor or truck mounting.



Hose Inside Dia. (in.)	Hose Length (ft.)	Hose Outlet (in.)	(F)NPT Reel Inlet (in.)	Dimensions	Model	Shpg. Wt.	\$ Each
3/8	25	1/4	3/8	12 3/4 x 4 7/8 x 12 1/2	FH35113	18.1	112.95
3/8	50	1/4	3/8	16 1/2 x 5 1/4 x 17 1/4	FH35113	31.9	158.95

Max Air Pressure - 300 psi. Max Temp. 150 °F

AIR AND BLOW GUNS

Economy –Lever-type blow gun.

Positive lever-control for full-range air delivery. Hanging hook is integral part of gun. Meets OSHA requirements.



NPT Outlet (in.)	Overall Length (in.)	Nozzle Type	Outlet Size (FNPT)	Body Material	Model	Shpg. Wt.	\$ Each
1/4	3 3/4	Standard Non Safety	1/8	Chrome Plated Zinc	FH35115	1.0	5.40

5-PIECE QUICK CHANGE COUPLER KIT

Patented quick change feature allows use to switch nozzles quickly and easily. Includes heavy-duty blow gun, high flow safety nozzle, 6" extension safety nozzle, rubber tip nozzle, rubber tip nozzle, needle tip nozzle, and air screen safety nozzle. Clear vinyl storage pouch included.



Desc.	Model	Shpg. Wt.	\$ Each
Heavy Duty Air Gun Kit	FH35116	0.65	33.70

3-WAY HOSE MANIFOLDS

Allows three work stations to use the same air supply. Each manifold accepts three quick couplers or outlet hoses.



Inlet (in.)	Outlet (in.)	Material	Model	Shpg. Wt.	\$ Each
FNPT 1/4	FNPT 1/4	Aluminum	FH35117	0.1	8.35
FNPT 3/8	FNPT 1/4	Aluminum	FH35118	0.1	9.79
FNPT 3/8	FNPT 3/8	Aluminum	FH35119	0.1	9.79

INDUSTRIAL INTERCHANGE COUPLERS

Quick-disconnect couplers and plugs allow for quick, positive air line connections. Buna N' Seals.



Connection Size (in.)	Body Size (in.)	Model	\$ Each
Female NPT Couplers			
1/4	1/4	FH35120	4.69
3/8	3/8	FH35121	9.95
Male NPT Plug			
1/4	1/4	FH35122	1.38

Max Air Pressure - 300 psi. Steel Material. Shpg. Wt. 0.1

LUBRICANTS, CLEANERS & LOCTITE

LUBRICANT SPRAY

Forms a clear, thin film that lubricates, prevents corrosion, displaces moisture, penetrates, and cleans. Leaves no sticky residue. NSF H2 Registered.

DRY LUBE

PTFE-based lubricant bonds to most surfaces and resists dirt, dust, and oil buildup. Contains no ozone depleting chemicals. Wide temperature range. NSF H2 Registered.

WHITE LITHIUM GREASE

NLGI 2 grease for any weather or temperature. White color makes it easy to visually inspect film coverage.

HYDROFORCE® SUPER CITRUS™ CLEANER

Effective in dissolving grease, oil, ink, grime, and adhesives, the d-Limonene based cleaner/degreaser is water-dilutable and completely biodegradable. Nonflammable.

THREADLOCKERS

Blue 24221- Medium Strength 10 mL
Red 26221- High Strength 10mL



Desc.	Model	Shpg. Wt.	\$ Each
11 oz. Lubricant Spray	FH39500	0.95	4.15
16 oz. Dry Lube	FH39501	0.9	7.25
10 oz. White Grease	FH39502	0.9	6.95
20 oz. Super Citrus	FH39503	1.2	9.50
242 Med. Threadlocker	FH39600	0.05	13.25
262 High Threadlocker	FH39601	0.05	12.65

MASTER SETS

SAE & Metric Master Sets



FH40100

Toolbox not included.



FH40101



FH40104



FH40102



FH40105



FH40103



FH40106

Description	Drive Size	Sockets/ Accs.	Wrenches	Pliers	Screwdrivers	Striking Tools	Misc. Tools	Brand	Model	Shpg. Wt.	\$ Each
1050 Piece	1/4, 3/8, 1/2, 3/4	602	115	33	27	29	244	Blackhawk	FH40100	470.0	5106.00
835 Piece	1/4, 3/8, 1/2	450	50	27	27	23	259	Blackhawk	FH40101	174.0	2508.00
624 Piece	1/4, 3/8, 1/2, 3/4	335	77	23	21	23	145	Blackhawk	FH40102	150.0	2330.00
584 Piece	1/4, 3/8, 1/2	370	67	19	24	26	78	Blackhawk	FH40103	190.6	2194.00
300 Piece	1/4, 3/8, 1/2	241	12	—	7	—	40	Blackhawk	FH40104	55.0	628.00
220 Piece	1/4, 3/8, 1/2	160	30	—	—	—	40	Blackhawk	FH40105	34.0	476.75
172 Piece	1/4, 3/8, 1/2	133	21	—	—	—	18	Blackhawk	FH40106	23.6	319.00

MULTI-DRIVE SOCKET SETS

- Blackhawk socket sets are high quality for industrial, construction, and automotive applications



FH40150



FH40151



FH40152

# of Pieces	Drive -Size	SAE or Metric	Socket Type	Sockets Included	Accessories	Model	Shpg. Wt.	\$ Each
82	1/4, 3/8, 1/2	Both	1/4" Drive: 6 Pt. Std. 6 Pt. Deep 12 Pt. Std. 3/8" Drive: 6 Pt. Std. 12 Pt. Std. 12 Pt. Deep 1/2" Drive: 12 Pt. Std.	5/32, 3/16, 7/32, 1/4, 9/32, 5/16, 11/32, 3/8, 7/16, 1/2" 4, 5, 6mm 3/16, 1/4, 9/32, 5/16" 3/16, 7/32, 1/4, 9/32, 5/16, 11/32, 3/8, 7/16, 1/2" 7, 8, 9, 10, 11, 13mm 3/8, 7/16, 1/2, 9/16, 5/8, 11/16, 3/4, 13/16" 9, 10, 11, 12, 13, 14, 15, 17, 19mm 3/8, 7/16, 1/2, 9/16, 5/8, 11/16, 3/4, 13/16" 9, 10, 11, 12, 13, 14, 15, 16, 17, 19mm 3/8, 7/16, 1/2, 9/16" 1/2, 9/16, 5/8, 3/4, 13/16"	1/4" Drive Round Head Knurled Reversible Ratchet 3/8" Drive Round Head Knurled Reversible Ratchet, 3" Extension, 5/8" Spark Plug Socket 1/2" Drive Round Head Knurled Reversible Ratchet	FH40150	13.3	121.50
23	1/4, 3/8	SAE	1/4" Drive: 6 Pt. Std. 3/8" Drive: 12 Pt. Std.	3/16, 7/32, 1/4, 9/32, 5/16, 11/32, 3/8, 7/16, 1/2" 7/16, 1/2, 9/16, 5/8, 11/16, 3/4, 13/16, 7/8"	1/4" Drive: Spinner 3/8" Drive: Drive Ratchet, 3 & 6" Extensions, 5/8" Spark Plug Socket, 3/8 x 1/4" Adapter	FH40151	5.3	39.30
65	1/4, 3/8	Both	1/4" Drive: 6 Pt. Std. 3/8" Drive: 12 Pt. Std.	5/32, 3/16, 7/32, 1/4, 9/32, 5/16, 11/32, 3/8, 7/16, 1/2" 4, 5, 6, 7, 8, 9, 10, 11, 12, 13mm 3/8, 7/16, 1/2, 9/16, 5/8, 11/16, 3/4, 13/16" 10, 11, 12, 13, 14, 15, 17mm	1/4" Drive: Spinner 3/8" Drive: Round Head Reversible Ratchet, 3" Extension, 3/8 x 1/4" Adapter, 5/8" Spark Plug Socket 13 Piece Hex Key Set, Bit Holder, Phillips #1, 2, 3, Slotted 3/16, 1/4, 9/32", Torx (R) T10, T15, T20, T25, T27 Insert Bits	FH40152	6.0	63.60

RATCHETING WRENCH SETS

12 Point Ratcheting Reversing Combination

- ◆ Blackhawk by Proto sets are available in a wide variety of sizes and finish for industrial, construction, and automotive applications.



Description	Size	Model	Shpg. Wt.	\$ Each
10 Pc. SAE/Metric	3/8, 7/16, 1/2, 9/16, 5/8", 10, 11, 12, 13, 14mm	FH40200	2.5	122.30
8 Pc. SAE	5/16, 3/8, 7/16, 1/2, 9/16, 5/8, 11/16, 3/4"	FH40201	2.6	75.65
8 Pc. Metric	8, 10, 12, 13, 14, 15, 17, 18mm	FH40202	2.6	75.65

ANTISLIP COMBINATION WRENCH SETS

- ◆ Blackhawk by Proto sets are available in a wide variety of sizes and finish for industrial, construction, and automotive applications.



Description	Finish	Size	Model	Shpg. Wt.	\$ Each
9 Pc. 12 Point SAE	Black	1/4, 5/16, 3/8, 7/16, 1/2, 9/16, 5/8, 11/16, 3/4"	FH40250	2.6	59.85
9 Pc. 12 Point Metric	Black	10, 11, 12, 13, 14, 15, 16, 17, 18mm	FH40251	2.6	59.85

HEX KEY SETS

- ◆ All hex keys are precision formed to exact dimensional tolerances for precise fit
- ◆ Heat treated alloy steel provides high strength and resistance to rotational distortion
- ◆ T-Handle Hex Keys have color coded handles

Replacement parts are available for Wiha products.



Description	# of Keys	Arm Length (in.)	Size	Model	Shpg. Wt.	\$ Each
Folding Hex Key Set	16	2.0 to 3.3	0.050, 1/16, 5/64, 3/32, 7/64, 1/8, 9/64, 5/32, 3/16", 1.5, 2, 2.5, 3, 4, 5, 6mm	FH40300	0.6	6.89
T-handle Hex Key Set	12	6.0	3/32, 1/8, 5/32, 3/16, 7/32, 1/4"; 2, 2.5, 3, 4, 5, 6mm	FH40301	1.2	21.35
L-shaped Hex Key Set	20	1.7 to 4.3	0.050, 1/16, 5/64, 3/32, 1/8, 5/32, 3/16, 7/32, 1/4, 5/16, 3/8", 1.5, 2, 2.5, 3, 4, 5, 6, 8, 10mm	FH40302	1.1	9.70

SCREWDRIVER SETS

- ◆ Tips are precision-machined to fit fasteners.
- ◆ Four-sided handle has broad, shallow flutes for a firm grip.



Description	Includes	Model	Shpg. Wt.	\$ Each
6-Pc. Round Shank	Slotted Stubby 1/4 x 1 9/16", Slotted 1/4 x 4", 5/16 x 6", 3/8 x 8", 3/8 x 10", Cabinet 3/16 x 4"	FH40320	2.2	50.00
6-Pc. Phillips Set	Stubby Phillips #2 x 1 1/2", Phillips #0 x 2 1/2", #1 x 3", #2 x 4", #3 x 6", #4 x 8"	FH40321	1.6	46.10
7-Pc. Torx Set	Torx T10 x 3 1/8", T15 x 1 1/4", T20 x 3 1/4", T25 x 3 1/4", T27 x 4", T30 x 4", T40 x 6"	FH40322	1.4	49.10

2-PIECE ADJUSTABLE WRENCH SETS



- ◆ Wide-capacity jaws
- ◆ Corrosion-resistant finish
- ◆ Drop-forged and heat-treated alloy steel construction
- ◆ NiKlear® multilayer plating and coating process.
- ◆ Cushion grip for comfort. Smooth-turning knurl for quick, easy jaw opening adjustments.

Max Opening	OAL Length (in.)	Model	Shpg. Wt.	\$ Each
15/16, 1 1/4	8, 10	FH40340	1.45	19.70
1/2, 3/4	4, 6	FH40341	0.4	15.30

PLIER AND TOOL SETS

- ◆ NiKlear® multilayer plating and coating process provides corrosion resistance.
- ◆ Hardened and tempered steel for strength and toughness. Slip-resistant vinyl grip handles for comfort.



FH40342
8" Slip Joint, 6 1/2" Locking Long Nose, 7 1/2" Diagonal Cutting, 10" Tongue & Groove Pliers

FH40343
8" Adjustable Wrench, 8" Long Nose, 8" Linesman, 10" Tongue & Groove Pliers

Desc.	# of Pieces	Model	Shpg. Wt.	\$ Each
Pliers Set	4	FH40342	2.75	22.25
Pliers Set	4	FH40343	2.9	34.30

MAGNETIC MULTIBIT RATCHETING SCREWDRIVER SET

Screwdriver is permanently magnetized for long service. Set includes Phillips: Nos. 1, 2 Pt.; Slotted: 5.0, 6.5 mm; Square: 1, 2 Pt.; Torx(R): T10, T15; Posi-Drive: 1, 2 Pt.



# of Pieces	Model	Shpg. Wt.	\$ Each
10	FH40360	0.7	16.25

HOT MELT GLUE GUN AND GLUE STICKS

Heavy-Duty Pro Electric Glue Gun

- ♦ All are trigger-feed
- ♦ Provides 40% more output.
- ♦ Protected nozzle and auto shutoff light ensure safety and extend life. High/Low temperature switch. Cushion grip.



Description	Watts	Voltage	Glue Capacity (in.)	Brand	Model	Shpg. Wt.	\$ Each
Heavy Duty Pro	80	120	1/2	Stanley	FH40380	1.2	26.55
Glue Sticks							
Glue Sticks 1/2" x 10" (24/Box)				Stanley	FH40381	1.5	12.19
Glue Sticks 1/2" x 10" (100/Box)				Stanley	FH40382	5.8	40.80

HAMMERS

Claw hammers are made of heat-treated high carbon steel. Antivibe hammers have patented tuning fork design that reduces harmful vibrations and fatigue. Jacketed graphite and fiberglass hammers provide overstrike protection.



RIP CLAW



CURVED CLAW



FRAMING

Description	Head Wt. (oz.)	OAL (in.)	Handle	Face	Face Dia. (in.)	Brand	Model	Shpg. Wt.	\$ Each
Curved Claw Hammer	16	13 1/4	Hickory	Smooth	1 3/16	Stanley	FH40400	1.4	9.50
Rip Claw Hammer	22	16	Steel w/Anti-Vibration Grip	Smooth	1 11/32	Stanley	FH40401	2.2	31.25
Rip Claw Hammer	22	16	Steel w/Anti-Vibration Grip	Milled	1 11/32	Stanley	FH40402	2.3	32.15
Framing Hammer	22	18	Hickory Black Lacquer Finish	Smooth	1 1/2	Stanley	FH40403	2.3	27.30
Farming Hammer	22	18	Hickory Black Lacquer Finish	Milled	1 1/2	Stanley	FH40404	2.2	27.85

RUBBER Mallet



Head Wt. (oz.)	OAL (in.)	Face Dia. (in.)	Head Length (in.)	Handle	Head Material	Brand	Model	Shpg. Wt.	\$ Each
18	13 3/4	2 3/8	3 15/16	Lacquered Wood	Rubber	Stanley	FH40405	0.6	14.75

WRECKING/PRY BARS AND NAIL PULLERS

FH40406 has a larger cross-sectional area than a standard 3/4" hexagonal bar. Includes additional slot specifically for pulling nails (size 2d through 20d).

FH40409 FatMax® Xtreme™ functional utility bar is a one-piece forged bar with a tempered striking face and a special extracting claw with beveled nail slot. A bi-material grip is molded directly onto the bar for greater comfort. The wrecking bar can be used to straighten, split, pry, carry, rip, and bend.



Description	OAL (in.)	Material	Color	Model	Shpg. Wt.	\$ Each
Gooseneck Wrecking Bar	24	Hear Tempered Steel	Yellow	FH40406	5.3	18.00
Pry Bar	12 3/8	Forged High Carbon Steel	Black	FH40407	1.3	10.29
Nail Puller	12	Heat Treated High Carbon Steel	Gray	FH40408	1.0	20.54
Universal Wrecking Tool	18	Forged High Carbon Steel w/ Cushion Grip	Silver	FH40409	1.0	44.00

HAMMER TACKER

Loads 2 strips of staples.
Rubber grip. Designed to last 200,000 cycles.
♦ Uses staples-1/4, 5/16, and 3/8"



Desc.	Brand	Model	Shpg. Wt.	\$ Each
Steel	Stanley	FH40440	2.2	31.50

SHARP SHOOTER® STAPLE GUN

Low stroke handle to reduce hand fatigue.
Aluminum cast housing for durability. Easy access staple insertion and anti-jam mechanism.
♦ Uses heavy-duty narrow crown staples-1/4, 5/16, 3/8, 1/2, and 9/16"; 6, 8, 10, 12, and 14mm



Desc.	Brand	Model	Shpg. Wt.	\$ Each
Staple Gun	Stanley	FH40441	1.6	25.95

MALLETS

These Round Head Mallets feature a tough urethane 360° striking surface that is non marring and very quiet to use.



Size	Model	Shpg. Wt.	\$ Each
12 oz.	FH40450	1.0	17.95
18 oz.	FH40451	1.0	18.95
24 oz.	FH40452	1.0	20.95
30 oz.	FH40453	1.0	22.95

RADIUS PLANES

JACK PLANE

The Jack Plane with its longer sole produces a very flat surface. Made of precision ground cast iron, this plane features a micro depth adjustment mechanism, a quick release lever cap and a lateral adjustment lever for outstanding control. Like all fine woodworking tools, this plane is a pleasure to use. Jack Plane measures 14" long.

SMOOTHING PLANE

The Smoothing Plane is the workhorse in the shop. Designed to smooth rough-sawn lumber, it is also the tool of choice for planing doors and windows as well as other planing chores around the shop. Hardwood handle and knob provide tremendous control. Smoothing Plane measures 9-3/4" long.

BLOCK PLANE

This low angle Block Plane is perfect for trimming across the grain as well as with the grain for perfect fits. Cast iron construction, precision milling and accurate adjustment mechanisms make this plane the perfect tool for on the job or in the shop. Block Plane measures 6-7/8" long.



Desc.	Model	Shpg. Wt.	\$ Each
Jack 2" x 14"	FH45000	1.0	49.85
Smoothing 2" x 9-3/4"	FH45001	1.0	35.85
Block 1-5/8" x 6-7/8"	FH45002	1.0	15.85

FILE CARD & BRUSH

Clean rasps and files cut faster and save time. This File Card and Brush has one side that quickly removes tough imbedded filings and the other has stiff polypropylene bristles for cleaning rasps and knocking off dirt and oxidation prior to filing. This is one of those items that's worth its weight in gold!



Desc.	Model	Shpg. Wt.	\$ Each
File Card & Brush	FH45003	0.5	5.95

ROSEWOOD HANDLE AWL

Nothing beats an Awl for layout work and center-hole marking. Because the tip is so fine, it produces much more accurate results than a sharpened pencil. Measures 8" overall.



Desc.	Model	Shpg. Wt.	\$ Each
Awl	FH45004	0.5	8.25

12" UNDERCUT SAW

Two-sided saw blade cuts left and right. 10 TPI Shark teeth cut aggressively on the pull stroke. Offset hardwood handle and ball knob provide unsurpassed cutting control.



Desc.	Model	Shpg. Wt.	\$ Each
12" Undercut Saw	FH45005	0.5	22.50

3 PC. WOOD RASP SET

This 3-Pc. Wood Rasp Set with rubber handles includes Round Rasp, Flat Rasp and Half-round Rasp. Ideal for wood carvers. Aggressive teeth remove wood fast for any wood shaping need. Rasps measure 12" overall.

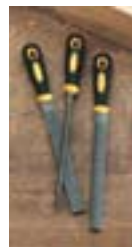

Desc.	Model	Shpg. Wt.	\$ Each
3 Pc. Wood Rasp Set	FH45006	1.5	9.95

6 PC. FILE SET

Sure-grip rubber handles make this 6-Pc. Rasp File Set a pleasure to use. Set includes Round Rasp File, Square Rasp File, Half-round Rasp File, Triangular Rasp File, Flat Rasp File and Tapered Flat Rasp File. Rasp Files measure 2-1/4" overall.



Desc.	Model	Shpg. Wt.	\$ Each
6 Pc. File Set	FH45007	2.0	19.95

CHISEL AND PUNCH SET

Carbon Tool Steel- 4" to 7"
Set includes- Hand Cold Chisel: 5/16, 3/8, 1/2, 5/8, & 3/4"; Flat Cape Chisel: 1/2"; Diamond Point Chisel: 3/8"; Center Punch: 7/16 x 5 1/2"; Prick Punch: 3/8 x 5"; 5 Pin Punches: 5/16 x 5"; 5/16 x 5 1/4"; 5/16 x 5 1/2"; 3/8 x 7"; 1/2 x 7"



# of Pieces	Model	Shpg. Wt.	\$ Each
14	FH40442	3.5	83.95

SLICKPLANE®

The Slickplane® produces an exceptionally smooth 1/16" radius or a 45° chamfer over the entire length of an edge. A brass sole glides easily along the work piece edge as two independently adjustable carbide-tipped cutters apply the finishing touch.



Desc.	Model	Shpg. Wt.	\$ Each
Slickplane®	FH45008	0.5	15.95
Replacement Blades (2)	FH45009	0.5	8.95
Chamfer Blades (2)	FH44010	0.5	8.95

CORNER CHISEL

Turn rounded corner angles into right-angles. A slight hammer tap gives you perfect corners every time. Spring loaded, perfect for hinge plates. Working depth: 5/8" Cutting edge: 3/8"



Desc.	Model	Shpg. Wt.	\$ Each
Corner chisel	FH44011	0.2	10.95

4-PIECE NAIL SET

These case hardened nail sets are conveniently packages in sets of four tip sizes. Bright fluorescent colors identify which nail set is which and pretty much guarantees they won't end up lost. Tip sizes include 1/32", 1/16", 3/32" and 1/8".



Desc.	Model	Shpg. Wt.	\$ Each
4-Piece Nail Set	FH44012	0.3	6.50

DISPOSABLE BURR TOOL

Low-cost throwaway deburring tool features pocket clip on handle. Uses one E-100 blade (for Steel and Aluminum), included. Sold in packages of 10.



Desc.	Model	Shpg. Wt.	\$ Each
Disposable Burr Tool	FH44013	0.5	30.75
Burr Handle	FH44014	0.1	3.50
E-100 Blades	FH44015	0.1	19.50

HANDSCREWS

Provide evenly controlled clamping pressure. Easily adjust to surfaces that are not parallel. Spindles are cold drawn steel with quick-acting, double lead thread.

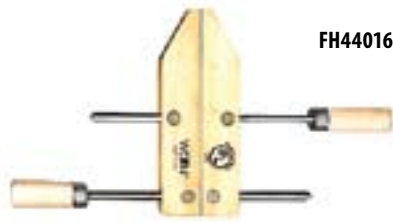

Jaw Length (in.)	Max Jaw Opening (in.)	Throat Depth (in.)	Model	Shpg. Wt.	Each
6	3	3	FH44016	1.0	19.25
8	5	4	FH44017	2.4	22.50
10	7	5	FH44018	2.7	25.70
12	9 1/4	6	FH44019	4.3	30.00
14	10 3/4	7	FH44020	5.3	35.50

G-CLAMPS

Drop Forged Clamps

Extra-Deep Throat Series

Combines greater strength with extra-deep throat. Hardened spindles will not bend.



Size (in.)	Capacity (in.)	Throat Depth (in.)	Capacity (lbs.)	Brand	Model	Shpg. Wt.	\$ Each
3	0-3	2 1/2	3500	Wilton	FH44021	2.0	23.25
4	0-4 1/4	3 1/4	6200	Wilton	FH44022	3.4	25.75
6	0-6 1/16	4 1/8	6600	Wilton	FH44023	5.2	35.50
8	0-8 1/4	5	6900	Wilton	FH44024	7.8	46.50

SLIDING ARM SPRING CLAMPS

Infinitely adjustable sliding arm design opens up to 4". Handles the work of 1, 2, 3, and 4" standard spring clamps. Includes ergonomic grips and soft pads for damage-free clamping.



Max Jaw Opening (in.)	Length (in.)	Brand	Model	Shpg. Wt.	\$ Each
2 3/8	5	Bessey	FH44025	0.2	6.25
4 1/4	6 1/2	Bessey	FH44026	0.4	7.30

NEED A PRODUCT WE DON'T HAVE LISTED?

Call our sales staff, we can source any product that you need.

SPRING CLAMPS

Tempered steel spring provides increased pressure at jaw tip. Grip securely with ergonomic design. Polyvinyl handle and tips.



Size (in.)	Max Jaw Opening (in.)	Model	Shpg. Wt.	\$ Each
4	1	FH44027	0.2	1.83
6	2	FH44028	0.4	3.09
9	3	FH44029	0.9	6.15

CORNER CLAMP

Creates perfect 90 Degree joints. Holds work up to 3" wide. Joints are fully exposed for nailing, gluing, or doweling. Two counter-sunk holes allow clamp to be mounted to work surface.



Desc.	Model	Shpg. Wt.	\$ Each
Corner Clamp	FH44030	0.2	9.10

JOINTER CLAMPS

Stainless steel, spring-form design quickly creates 90 Degree joints on wood, particle board, and other light materials. Clamps self-align on materials up to 3/4" thick to create T-joints, mitre joints, and butt joints. 2 per. pkg.



Desc.	Model	Shpg. Wt.	\$ Each
3H x 1 3/4W Jaws	FH44031	0.8	29.40

BAR CLAMPS

Multiple disc clutch provides quick adjustment, secure hold and instant release. Steel bar is zinc plated. Heavy-duty deep reach clamps have 4 3/4" wood screw handle. Include plastic caps for pad and anvil.



Max Jaw Opening (in.)	Throat Depth (in.)	Load Capacity (lbs.)	Bar Size (in.)	Brand	Model	Shpg. Wt.	\$ Each
12	2 1/2	600	1/4" x 3/4"	WILTON	FH44032	1.8	6.35
18	2 1/2	600	1/4" x 3/4"	WILTON	FH44033	1.0	7.35
24	2 1/2	600	1/4" x 3/4"	WILTON	FH44034	2.3	8.00
36	2 1/2	600	1/4" x 3/4"	WILTON	FH44035	2.5	9.40

BAR CLAMPS/SPREADERS

Irwin Quick Grip

Quick-Change jaw quickly converts from clamp to spreader without the use of tools. High-tech reinforced resin construction provides strength and durability. Provides up to 250 lbs. of clamping pressure. Pistol grip design enhances comfort and ease of use. Non-marring pads grip firmly to protect work.



FH44036

Description (in.)	Spreading Range (in.)	Model	Shpg. Wt.	\$ Each
6	7 1/2-14 5/8	FH44036	1.7	20.90
12	7 1/2-20 5/8	FH44037	2.0	24.50
18	7 1/2-26 5/8	FH44038	2.3	26.50
24	7 1/2-32 5/8	FH44039	2.7	28.20
36	7 1/2-44 5/8	FH44040	3.0	32.10

ONE-HANDED CLAMP AND SPREADERS

Simply turn a knob to change function from clamping to spreading.

Large, flat clamping jaws have soft pads for sensitive surfaces, right angles, and rounded/pointed work pieces. Includes pump lever for easy clamping and quick release button.



FH44041

Clamping Capacity (in.)	Spreading Range (in.)	Throat Depth (in.)	Brand	Model	Shpg. Wt.	\$ Each
6	3 to 9 1/4	3 1/4	Bessey	FH44041	1.5	28.50
12	3 to 15	3 1/4	Bessey	FH44042	1.7	29.40
18	3 to 21	3 1/4	Bessey	FH44043	1.9	30.70
24	3 to 27	3 1/4	Bessey	FH44044	2.2	32.20

MINI BAR CLAMPS

25% smaller than Quick-Change clamps; use for smaller projects or confined spaces. Constructed of high-tech reinforced resin for strength and durability. Exerts up to 150 lbs. of clamping pressure. Patented pistol grip design enhances comfort and ease of use. Non-marring pads grip firmly and protect work.



Desc. (in.)	Throat Depth (in.)	Model	Shpg. Wt.	\$ Each
6	2 7/16	FH44045	1.5	30.65
12	2 7/16	FH44046	1.8	36.55

HANDI-CLAMPS™

Unique curved bar clamp reaches around odd shapes and allows you to adjust clamping pressure to meet the needs of the project. Jaws are designed to reach around odd shapes. One-handed operation: simply squeeze the quick release trigger to control pressure. Durable resin construction with non-marring swivel pads.



Desc.	Model	Shpg. Wt.	\$ Each
2" Curved Bar Clamp	FH44047	0.4	5.95
4" Curved Bar Clamp	FH44048	0.6	6.80

BAND CLAMP

15-ft. long, extra-wide strap for reduced stretch. 3 removable jaw pads for securing geometric and irregular shapes. Jaws are made of non-marring plastic. Bi-material handle for comfort and torque. Spring loaded band locks stay open during use. Die-cast aluminum alloy lock mechanism for strength and durability.



Desc.	Model	Shpg. Wt.	\$ Each
11" Band Clamp	FH44049	1.2	14.75

RETRACTABLE AND FIXED BLADE UTILITY KNIVES

Fully retractable blades control depth of cut and have blade storage for replacement blades. Fixed blades are always exposed and ready to cut with less chance of blade slipping back into knife.



FH44050



FH44051

FH44052



UTILITY KNIFE REPLACEMENT BLADES



For Use With	Qty.	Model	Shpg. Wt.	\$ Each
FH44050	5	FH45053	0.1	1.55
FH44051	5	FH45054	0.1	1.50
FH44052	5	FH45055	0.1	2.10
FH44052	100	FH45056	1.0	20.60

Description	OAL (in.)	Knife Material	Blade Change	Blade Type	# of Blades	Brand	Model	Shpg. Wt.	\$ Each
QuickSlide™ Pocket Utility Knife	5 3/4	Magnesium	Swivels Open	2-Sided Utility	3	Stanley	FH44050	0.5	10.50
Classic 99°	6	Cast Metal	Phillips Screw	2-Sided Utility	3	Stanley	FH44051	0.4	4.90
Outdoorsman™ Folding Knife w/ Retractable Blade	6 1/4	Steel w/Rubber	Push Button Change	3 1/2 Serrated Folding Blade	10	Stanley	FH44052	0.8	25.45

HAND TOOLS

STUDSENSOR™ PRO SL-AC WALL SENSOR

Provides added safety by continuously detecting hot AC wires. Locates standard 120/240VAC wiring in plastic conduit or Romex cable. Finds wood and metal studs. Select between 3/4" scan depth and patented 1 1/2" DeepScan® mode. Features SpotLite® pointing system with LED stud indicator and audio signal. Also features TruCal® instant calibration.



Description	Scan Depth (in.)	Scans	Model	Shpg. Wt.	\$ Each
StudSensor™ Pro SL-AC	1 1/2	Drywall, Wood, Paneling	FH45057	0.4	30.25
TriScanner® Pro SL	3	Drywall, Wood, Paneling, Concrete, & Most Floor, Wall, & Ceiling Coverings	FH45058	0.4	40.35

TRISCANNER® PRO SL WALL SCANNER

Exclusive, patented SpotLite® pointing system clearly identifies location of studs, pipes, and rebar. Detects wood and metal studs through drywall or paneling up to 1 1/2" thick, metal pipes up to 1 1/2" deep, and rebar up to 3" deep, while AC safety feature continuously detects hot, unshielded electrical wires. TruCal® for instant calibration ensures accuracy. Recessed LED display and audio signal identifies target edges. Rugged case includes a rubberized grip.



CALIPERS

MITUTOYO DIGIMATIC DIGITAL CALIPER

Feature enlarged LCD, as well as Zero, On/Off, and Inch/mm control buttons. Jaw Range: 0-6"/0-150mm

MITUTOYO DIAL CALIPERS

Dial movement provides extra shock protection for the gear train. Hardened stainless steel calipers offer inside, outside, depth, and step measurements with thumb roller and slider lock. Come with a case. Jaw Range: 0-6"



FH45061



FH45062

Type	Jaw Depth (in.)	Model	Shpg. Wt.	\$ Each
Electronic	1.60	FH45061	0.2	41.45
Dial	1.57	FH45062	1.0	102.35

CONSTRUCTION CALCULATORS

MEASURE MASTER™ PRO

For Woodworkers, Cabinet Makers & Craftsmen
Converts Feet/Inches/Fractions 1/2, 1/4, 1/8, 1/16, 1/32 And 1/64/Decimal Feet/Inches/Yards/Meters/Centimeters/ Millimeters, Square/Cubic/ Area/Volume/Circumference/ Circle Area/Arc Lengths/ Weight/Volume, 8-12 Minute Auto Shutoff, Silicone Rubber Keys, Preset Fraction Denominators, Review Last 20 Entries



FH45059

SCALE MASTER® CLASSIC

For Contractors, Estimators, Engineers & Architects
Blueprint Takeoffs, Calculates Linear/ Area/Volume/Feet/ Inches/Yards/ Millimeters/Meters, Square/Cubic Formats, and Decimal Feet/Inches, 72 Built-In and 6 Custom Scales, 2 Built-In Memories, Lock Switch, Built-In Counter, Rolls in Either Direction/Any Hand



FH45060

Description	Power Supply	Model	Shpg. Wt.	\$ Each
Measure Master™ Pro	(2) 1.5V Alkaline Batteries	FH45059	0.3	40.80
Scale Master® Classic	(2) 3V Lithium Batteries	FH45060	0.3	71.40

WHEEL MARKING GAUGE

This simple, yet effective Marking Gauge has a single bevel edge wheel that scribes a fine line without tearing the wood fibers and does not wander with the wood's grain. 8" long.



Desc.	Model	Shpg. Wt.	\$ Each
Wheel Marking Gauge	FH45063	1.0	10.75

MEASURING TAPES

FATMAX®

Large graphics and BladeArmor™ industrial thermoplastic coating on the first 6 inches of tape. 11-ft. standout.



STANLEY®

Three rivets and corrosion-resistant hook. Blade has Mylar® polyester coating and high contrast graphics. 7-ft. standout.



FRACTIONAL MEASUREMENT

Description	Blade Width (in.)	Length (ft.)	Graduations	Stud Markings	Model	Shpg. Wt.	\$ Each
FatMax®	1 1/4	25	In/Ft	Yes	FH45064	1.2	28.00
FatMax®	1 1/4	35	In/Ft	Yes	FH45065	1.6	38.50
Stanley®	1	25	In/Ft/Fractional	Yes	FH45066	0.9	11.20
Stanley®	1	25	In/Ft	Yes	FH45067	0.9	13.60

ALUMINUM LEVELS

ALUMINUM LEVEL SETS

Door jamb kits have patented hex key calibration. Earth magnets allow hands-free work with metal applications. Continuous edge center vial. Machined acrylic vials provide 0.0005 in./in. accuracy. Kits include two box beam sizes.



FH45068

BOX BEAM

Extruded aluminum profile. Patented hex key calibration. Acrylic yellow vials with interior permanent vial markings. FatMax® levels feature block vials with accuracy to 0.0005 in./in. (0.5mm/m).



FH45070

Description	Length (in.)	No. of Vitals	Plumb	Level	Brand	Model	Shpg. Wt.	\$ Each
Door Jamb Kit	78 & 32	3	2	1	Irwin	FH45068	7.2	183.00
Magnetic Door Jamb Kit	78 & 32	3	2	1	Irwin	FH45069	7.7	212.00
Box Beam Fatmax®	48	3	2	1	Stanley	FH45070	2.0	26.25
Box Beam Fatmax® Xtreme™ Magnetic	48	3	2	1	Stanley	FH45071	3.1	43.00

ALUMINUM MAGNETIC LEVELS

Durable, heavy-duty cast aluminum frame has top-read vial for pipe and conduit work.

Replaceable, 360° acrylic vials are tinted for easy reading. Magnetic strip allows hands-free operation on metal surfaces.



FH45072



FH45073



FH45074

Description	Length (in.)	No. of Vitals	Plumb	Level	Brand	Model	Shpg. Wt.	\$ Each
Magnetic Torpedo Level	9	3	2	1	Stanley	FH45072	0.2	9.20
Magnetic, Aluminum	9	3	1	1	Stanley	FH45073	0.3	14.10
Magnetic, Lighted	9	3	1	1	Stanley	FH45074	0.3	19.00

SQUARES

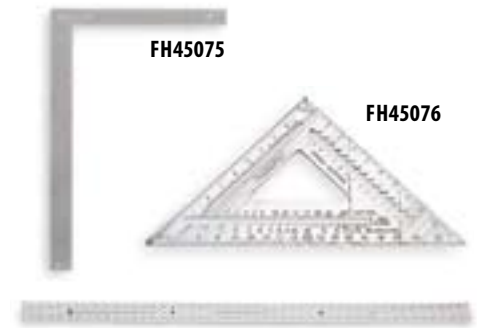

Desc.	Model	Shpg. Wt.	\$ Each
16 x 24" Steel Carpenter's Square	FH45075	1.7	6.95
12" Aluminum Milled Rafter Angle Square	FH45076	1.5	15.95
48" Aluminum Straight Edge	FH45077	1.0	7.50

MEASURE MASTER® MARKING WHEEL

Durable, compact unit has precision molded wheels and counters housed in high-impact polycarbonate housings with push-button reset and magnifying glass.

- ♦ Adds and subtracts
- ♦ Safety green color
- ♦ 10,000 ft. Measuring Capacity



Desc.	Model	Shpg. Wt.	\$ Each
1 ft. Wheel Single	FH45078	1.4	47.95

SPEED-LINE CHALK LINE REEL

All reels include 100-ft. of cord and 2 oz. of Blue Marking Chalk. Features die-cast metal plates and a 6:1 helical gear system.



Desc.	Model	Shpg. Wt.	\$ Each
Chalk Line Reel	FH45079	0.9	11.50

HAND TOOLS

TRAXX® SERIES INDUSTRIAL TOOL BOXES

Posi-Latch™ drawer system keeps tools safe and secure with drawers that latch. Ball bearing, full-extension slides work smoothly. Sidewall post construction adds strength while reducing overall weight. Drawers are interchangeable. 1200-lb. load rating. Drawer liners included.

- ♦ Tool carts and side cabinets come with hardboard work surface
- ♦ 6 x 2" casters on 52 and 60" tool carts
- ♦ All 41" tool carts include 5 x 2" casters (not installed)
- ♦ Heavy-duty handle on the side
- ♦ Cabinets are reinforced for extra strength



Description	Color	Overall Dimensions (in.)		Model	Shpg.	
		W x D x H			Wt.	\$ Each
11-Drawer 41" Chest	Black	40 1/2 x 17 1/2	19 3/4	FH45080	156.0	789.00
11-Drawer 41" Chest	Blue	40 1/2 x 17 1/2	19 3/4	FH45081	156.0	789.00
12-Drawer 41" Tool Cart	Red	40 3/4 x 18 x 41 1/4		FH45082	253.0	998.00
12-Drawer 41" Tool Cart	Black	40 3/4 x 18 x 41 1/4		FH45083	253.0	998.00
12-Drawer 41" Tool Cart	Blue	40 3/4 x 18 x 41 1/4		FH45084	253.0	998.00
13-Drawer 52" Tool Cart	Red	51 1/2 x 20 x 42 1/2		FH45085	195.0	1498.00
13-Drawer 60" Tool Cart	Red	58 1/2 x 20 x 42 1/2		FH45086	387.0	2098.00
13-Drawer 60" Tool Cart	Black	58 1/2 x 20 x 42 1/2		FH45087	387.0	2098.00
13-Drawer 60" Tool Cart	Blue	58 1/2 x 20 x 42 1/2		FH45088	387.0	2098.00

WORKSITE CHEST AND ROAD BOX

6-DRAWER WORKSITE CHEST

Double-wall construction provides added strength and durability. Reinforced drop-front security panel with gasket closure protects tools from weather and theft. Full-extension, heavy-duty drawer slides.



6-DRAWER ROAD BOX

Heavy-duty construction for improved durability. 2 bottom skid rails provide additional reinforcement and strength, while allowing access for a forklift.



Description	Color	Overall Dimensions (in.)		Model	Shpg.	
		W x D x H			Wt.	\$ Each
6-Drawer Worksite Chest	Black	26 x 13 3/4 x 16 1/4		FH45089	76.4	398.00
6-Drawer Road Box	Black	20 x 36 x 27 3/4		FH45090	207.0	925.00

SOFT-SIDED TOOL CARRIERS

Store everything you need to get the job done right in one trip to the job. Built with rugged materials to last and protect.



Desc.	Model	Shpg.	
		Wt.	\$ Each
23-Pocket Big Mouth Bag	FH45091	1.6	18.30
33-Pocket Big Mouth Bag	FH45092	2.4	22.35
24-Pocket Carpenter Bag	FH45093	4.2	38.75
33-Pocket Carpenter Bag	FH45094	5.0	38.75

* Bag only - does not include tools

TOOL POUCHES



Desc.	Model	Shpg.	
		Wt.	\$ Each
8-Pocket Suede Pouch	FH45095	1.0	14.75
8-Pocket Top Grain Leather Carpenter's	FH45096	1.4	40.50

TOOL AND WORK BELTS

Custom designed to protect and hold tools and fasteners while keeping them organized and easily accessible. Fits 29 to 46 Waist sizes



Desc.	Model	Shpg.	
		Wt.	\$ Each
12-Pocket Leather	FH45097	2.3	50.50
18-Pocket Nylon Carpenter's	FH45098	4.1	98.00

LOCK CAGE

Provide security with an unobstructed view of operation and/or contents.

Modular design enables fast installation and easy relocation; more economical than woven wire. Easily trimmed panels will not unravel when cut or damaged. Panels are 8-gauge (0.162) galvanized wire welded into a 1 1/2 x 3" grid. 1" bends on the top and bottom add rigidity and provide a mounting point to bolt horizontally stacked panels together (hardware included). Heavy-duty 14-gauge 2 x 2" posts are welded to 7 x 2 x 1/4" predrilled mounting plate. Posts are predrilled for panel attachment (hardware included). Door track extends to prior panel post for increased strength. All doors include a cylinder lock with two keys.

Roofs, as well as custom sizes and heights are available.

Uses: Quality control areas, shipping offices, tool and supply rooms.

- ◆ Hinged door is available with a 3-ft. clear-width opening and a 94" clear height
- ◆ Sliding doors are available with a 4-, 6-, or 8-ft. clear-width opening and 96" clear height
- ◆ Galvanized finish is more durable than paint

Description (ft.)	Model	Shpg. Wt.	\$ Each
Panels (W x H)			
8' x 2'	FH46000	33.2	43.00
8' x 4'	FH46001	29.0	59.00
Doors (W x H)			
3' x 8' Hinge	FH46002	64.0	225.00
4' x 8' Slide	FH46003	98.0	300.00
6' x 8' Slide	FH46004	144.0	360.00
8' x 8' Slide	FH46005	165.0	560.00
Accessories			
8' H Post	FH46006	18.0	49.00
2' H Post Extension	FH46007	6.0	12.00
4' H Post Extension	FH46008	10.0	20.00
Wall Clamp Kit	FH46009	7.0	29.00

(*Nominal Size. Panel length is designed to fit between posts 8' apart from center of post to center of post.



HOW TO ORDER LOCK CAGE

1. Make a rough sketch of the proposed enclosure. Mark overall dimensions on the drawing.
2. Determine location, size, and type of doors and indicate on drawing. To fill space above the doors on 10 and 12 ft. high partitions, order a transom kit includes the appropriate height panel and mounting hardware. Panel needs to be cut to length.
3. Wall kit must be ordered for each connection point to existing walls.
4. Posts must be used between each panel, on both sides of the door and at the corners. Standard post is 8 ft. high. Order post extensions to make 10 and 12 ft. high posts.
5. For lengths less than 8 ft. wide, panels can be trimmed to size.

PRE-DESIGNED ROOM KITS

Standard-size room kits include components listed above, installation instructions, and door hardware.

4-ft. wide x 8-ft. high slide door with cylinder lock and keys on the width side.

ROOM	WALL			EXISTING WALL			EXISTING WALL		
	Model	Shpg. Wt.	\$ Each	Model	Shpg. Wt.	\$ Each	Model	Shpg. Wt.	\$ Each
8 x 12 x 8	FH46010	292.0	729.00	FH46014	415.0	880.00	FH46018	485.0	1165.00
12 x 12 x 8	FH46011	339.0	842.00	FH46015	491.0	1105.00	FH46019	561.0	1389.00
12 x 16 x 8	FH46012	368.0	903.00	FH46016	520.0	1230.00	FH46020	619.0	1510.00
16 x 16 x 8	FH46013	397.0	992.00	FH46017	549.0	1342.00	FH46021	695.0	1684.00

Full House Services

SET-UP & TRAINING

Full House can help set-up your machinery. We also provide on-site training for your employees.

SERVICE PROGRAMS

Our team can provide a detailed service schedule to keep your machines running at peak performance.

LEASE PROGRAMS

Have a big project coming up? Full House has a leasing program to help you when you need it most

TRADE-INS

Want to upgrade? Full House buys back some used machinery.

SHOP LAYOUT

Full House offers assistance in shop layout and material flow. With years of experience in over 1,000 door shops, we can help you layout your shop for maximum efficiency.

VAN RACKS

HEAVY DUTY ROOF MOUNTED VAN RACKS

VR-1500 Series

Roof Mounted for Vans Without Rain Gutters are recommended for commercial use for loads up to 600 lbs. in steel and 400 lbs. in aluminum. Can carry loads up to 800 lbs. with a third cross member in steel, 600lbs. with a third cross member in aluminum. Roof mounted overhead cargo carriers fit all Vans without rain gutters. Wide footed mounts can adjust to varying roof pitches or curves and should attach to the roof over the cross members, rubber pads are supplied to protect the body.

Features

- ◆ Available in both pairs (2) and single units.
- ◆ A third rack should be used for short loads and extra support when necessary.
- ◆ Tie down loops are provided for securing cargo.
- ◆ Comes complete with all mounting hardware and instructions.
- ◆ Rubber mounting pads included.



CARRY LOADS UP TO 1,000 LBS. WITH A THIRD AND FOURTH CROSSBAR.

Description	Max Capacity (lbs.)	Material	Model	Shpg. Wt.	\$ Each
Mini Van- 2 Sets of Crossrails	600	Black Steel	FH48600	35.0	132.95
Mini Van- 2 Sets of Crossrails	600	White Steel	FH48601	35.0	132.95
Mini Van-2 Sets of Crossrails	400	White Aluminum	FH48602	14.0	168.95
Mini Van-3 Sets of Crossrails	800	Black Steel	FH48603	53.0	198.95
Mini Van-3 Sets of Crossrails	800	White Steel	FH48604	53.0	198.95
Mini Van-3 Sets of Crossrails	600	White Aluminum	FH48605	21.0	253.95
Mini Van- 1 Extra Crossrail	-	Black Steel	FH48606	18.0	75.95
Mini Van- 1 Extra Crossrail	-	White Steel	FH48607	18.0	75.95
Mini Van- 1 Extra Crossrail	-	White Aluminum	FH48608	7.0	95.95

REAR SEAT STORAGE SOLUTIONS

For Chevrolet, GMC, Ford, Dodge, Nissan & Honda Trucks & More!

Want to secure all those odds and ends that slide around in the back seat of your truck? Here's the perfect solution. The DU-HA® storage unit stows either under or behind the rear seat(s) of your pickup truck and is made of durable heavy-duty polyethylene, making it virtually indestructible.



Optional DU-HA® Security Lock

Legal Gun Case in 47 States

Desc.	Model	Shpg. Wt.	\$ Each
Under Seat Storage Unit	FH DUHA1		146.00
Behind Seat Storage Unit	FH DUHA2		129.00
Security Lock	<i>Contact FHS for availability and \$</i>		

Call FHS for for your truck model!

COMMERCIAL VAN LADDER RACK

QTL (Quick to Lock) series

Quick to Lock series is available for full size vans and mini vans.

The QTL series all feature full-length side rails which permit one man loading and unloading of ladders with a "hooked" front end. This permits you to lean one end of the ladder against the front hook and swing it up onto the rear of the rack. Then, simply use the quick locking mechanism to secure the ladder to the rack. Clamps have an aluminum wear plate against rusting while the handles are rubberized for added protection plus there is provision for a pad lock in the closed position to prevent theft when your ladder is left unattended. Cross rails are pitched for easier loading and unloading and an accessory center cross rail is available for shorter ladders.

All models come in a tough powder coated white finish complete with all mounting hardware in UPS/Fed Ex shippable boxes for ease of shipment and handling.



Lock Options	Vehicle Fit	Material	Model	Shpg. Wt.	\$ Each
Passenger Side Only	All Dodge, All Ford & Chevy/GMC	Steel	FH48609	62.0	320.95
Passenger Side Only	All Dodge, All Ford & Chevy/GMC	Aluminum	FH48610	62.0	427.95
Passenger Side & Driver Side	All Dodge, All Ford & Chevy/GMC	Steel	FH48611	72.0	427.95
Passenger Side & Driver Side	All Dodge, All Ford & Chevy/GMC	Aluminum	FH48612	72.0	569.95

Description	Vehicle Fit	Material	Model	Shpg. Wt.	\$ Each
Extra 3rd Crossrail	All Dodge, All Ford & Chevy/GMC	Steel	FH48613	36.0	160.95
Extra 3rd Crossrail	All Dodge, All Ford & Chevy/GMC	Aluminum	FH48614	31.0	213.95

TRUCK RACKS

LIGHT DUTY SINGLE SIDED PICKUP TRUCK RACKS

Available for all full size and compact pickup trucks. This rack mounts to the floor and the bedrail of the pickup truck and features adjustable arms. The mounting hardware attaches to the pickup and the unit is easily installed and removed when needed. This rack will carry loads up to 200 lbs. and can be used with toolboxes, bed liners & other accessories. Available in three styles; Horizontal (FH48800) for lowest height, Sloped (FH48801) for ease in loading, and Adjustable Slope (FH48802) that is able to be adjusted from horizontal to sloped positions.

Style of Crossrail	Vehicle Fit	Width of Rack (in.)	Max Height (in.)	Capacity (lbs.)	Model	Shpg. Wt.	\$ Each
Horizontal	All Full Size & Compact Pickups	27 - 36	54	200	FH48800	25.0	177.95
Sloped	All Full Size & Compact Pickups	27 - 36	66.675	200	FH48801	25.0	189.95
Adjustable Slope	All Full Size & Compact Pickups	27-36	66.675	200	FH48802	30.0	203.95



HEAVY DUTY PICKUP TRUCK LADDER RACKS

Available in a black powder coated steel or white powder coated aluminum with 1-1/2" x 2-1/2" legs, 1-1/2" square tube cross rails. Modular design allows for customizing to the individual needs of each customer. Comes with three cross rails as standard with Bull Nose side rails. Also, available with optional camper feet adaptor plates making for a single universal rack for all pickup trucks. High top camper caps require longer legs. Camper feet reduce the capacity of the racks by 250 lbs.

Accessories	Model	\$ Each
Foot Extension	FH48853	56.95
Camper Foot Adapter-Flat	FH48854	88.95
Camper Foot Adaptor-Stepped/Stepped Super Duty Ford	FH48855	88.95
Camper Foot Adaptor-Deep Step/Deep Step Super Duty Ford	FH48856	88.95



Description	Material	Capacity (lbs.)	Model	Shpg. Wt.	\$ Each
Legs w/Over-the-Cab Bull-Nose Siderail	Heavy Duty Steel	850	FH48850	120.0	490.95
Extra Crossrail	Heavy Duty Steel	-	FH48852		88.95
Legs w/Over-the-Cab Bull-Nose Siderail	Aluminum	600	FH48851	120.0	653.95
Extra Crossrail	Aluminum	-	FH48859		128.95

RECEIVER HITCH CARGO CARRIER

The Hitch Carrier is great for all vehicles with crowded interiors and a must for those cargo items which might ruin a vehicles interior.

- ◆ Features a fully welded heavy-duty 10 gauge steel platform with expanded steel mesh flooring and gusseted supports.
- ◆ A eight inch high railing is also provided as a standard and is made from 1" square tubing.

This in turn surrounds the cargo on all sides to prevent it slipping off while still permitting easy cleaning. A hitch pin and clip is required (not provided). All carriers are powder coated black for years of outdoor service.



Platform Size (in.)	Receiver Tube Size (in.)	Max Capacity (lbs.)	Model	Shpg. Wt.	\$ Each
20 x 48	1¼ x 1¼	350	1252048	37.0	132.95
24 x 60	1¼ x 1¼	350	1252460	57.0	141.95
20 x 48	2 x 2	500	2002048	40.0	134.95
24 x 60	2 x 2	500	2002460	60.0	143.95

RECEIVER HITCH CARGO CARRIER FOR WORK AND PLAY

8' DOOR CART

The Door Cart is designed to handle interior and exterior pre-hungs and slabs. This heavy duty cart is designed and built to last in today's fast paced environment. Coated door dividers keep the doors separate and reduce damage. The dividers also eliminate the need to move every door when removing the door in the middle. Using the Diamond Door Cart in your shop will reduce unnecessary handling of door units from your door line to the truck.

- ◆ Heavy-duty Steel Frame, all Welded Construction
- ◆ Plywood Decking and 13 Adjustable Door Dividers
- ◆ Rubber Corner Bumpers and Foot Brake
- ◆ 6 wheel- 2 center solid & 4 corner swivel
- ◆ Max Capacity- 3,300 lbs.
- ◆ Dimensions- 96"L x 38"W x 70"H



Description	Model	Shpg. Wt.	QTY. 1-5 \$ Each	QTY. 6-11 \$ Each	QTY. 12 or more \$ Each
8' Diamond Door Cart	FH8DDC	257.0	850.00	750.00	695.00

8' L-SHAPED DOOR CART

Our Heavy Duty L-Shaped Door Cart is designed with a door shop in mind. Sturdy brace allows you lean interior and exterior pre-hungs and slabs to be moved quickly and safely around a warehouse.

- ◆ Heavy-duty Steel Frame, all Welded Construction
- ◆ Plywood Decking
- ◆ Rubber Corner Bumpers
- ◆ 6 wheel- 2 center solid & 4 corner swivel
- ◆ Max Capacity- 3,300 lbs.
- ◆ Dimensions- 96"L x 38"W x 70"H



Description	Model	Shpg. Wt.	QTY. 1-5 \$ Each	QTY. 6 or more \$ Each
L-Shaped Door Cart	FHDFC	225.0	795.00	695.00

8' TREE CART

Our sturdy Tree carts enable you to move jambs, casing and other moldings around a warehouse. Great for picking orders or handling inside the production area.

- ◆ 6 wheel- 2 center solid & 4 corner swivel
- ◆ Max Capacity- 3,300 lbs.



Description	Model	Shpg. Wt.	QTY. 1-5 \$ Each	QTY. 6 or more \$ Each
Tree Cart	FHDTC	220.0	795.00	695.00

STACKABLE DOOR RACK

The millwork rack is a stackable and moveable storage rack for doors, windows and practically anything that needs to be stored and moved around a warehouse. These versatile racks have the ability to be used as inventory racks or for staging orders as they come off assembly lines. Because of the way these racks can be arranged, you can minimize wasted floor space and maximize working space.

- ♦ Rugged steel construction along with 5/8" ply board gives the ability to store up to one ton of product.
- ♦ Four sides of fork lift pockets enable for easy accessibility
- ♦ Carts available for moving racks when building orders within your facility



106" DOOR RACK
112"H x 88.75"L x 44"D

88" DOOR RACK
94"H x 88.75"L x 44"D

44" DOOR RACK
51"H x 88.75"L x 44"D

Description	Model	Shpg. Wt.	QTY. 1-5 \$ Each	QTY. 6 or more \$ Each
44" Door Rack	FHDDR44	410.0	495.00	465.00
88" Door Rack	FHDDR88	483.0	575.00	545.00
106" Door Rack	FHDDR106	500.0	595.00	565.00
Rolling Base	FHDDRRB	70.0	250.00	

Custom Sizes Available



Rolling Bases

A-FRAME RACK

A-Frame racks are ideal for vertically storing timber, moldings, pipe and much more.

- ♦ The vertical display enables for easy access and order retrieval
- ♦ Adjustable M-dividers enable for simple organization of product being stored.
- ♦ A-Frame racks come in both single and double sided configurations
- ♦ Custom upright and deck sizes can be made to meet your needs



Description	Model	Shpg. Wt.	\$ Each
Starter Rack	FH14AFST	300.0	350.00
Add on Rack	FH14AFAD	205.0	250.00
M-Divider	FHAFMDV	13.0	15.00
Row Spacer	FHAF6RS	2.0	20.00

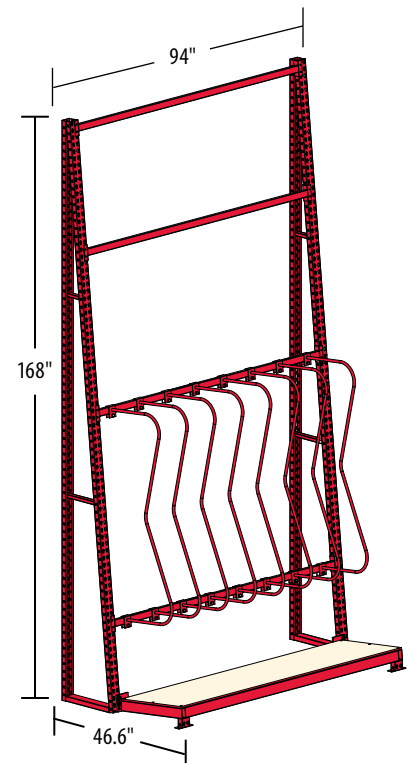

CANTILEVER RACK SYSTEMS

Structural beam cantilever racks are an excellent way to keep a neat and orderly inventory system for lumber, tubes, bars and other long heavy items that must be kept off the floor. They provide a fast, convenient place for heavy, long unwieldy materials and instant accessibility to one piece or a full load. For longer materials, simply add uprights and arms to fit your sizing requirements. Bases can also be used for extra storage.

- ◆ Racks are made from heavy duty structural beams
- ◆ Standard cantilevers come with three, four or five levels
- ◆ Bolt on arms and bases for assembly
- ◆ Arms can be adjusted vertically to accommodate the size of product
- ◆ Due to their rugged design, the racks can be used indoors or outdoors



MATERIAL HANDLING

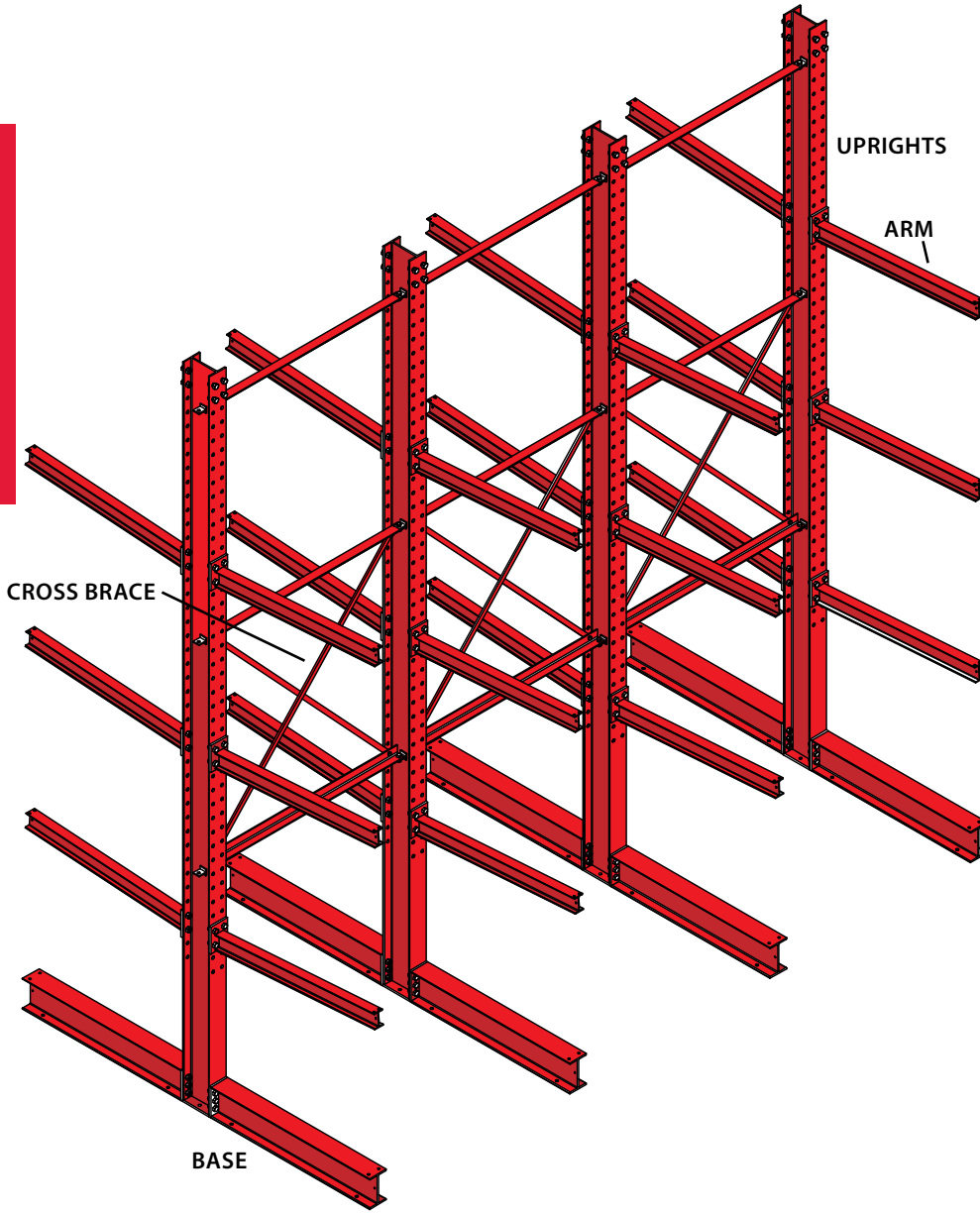

CANTILEVER BASE

Depth (in.)	Model	Shpg. Wt.	\$ Each
48	FHCNTB48	85.0	77.00
60	FHCNTB60	100.0	96.00

CANTILEVER ARM

Depth (in.)	Model	Shpg. Wt.	\$ Each
48	FHCNTA48	33.7	31.00
60	FHCNTA60	41.0	40.00

CANTILEVER UPRIGHTS

Height (ft.)	Model	Shpg. Wt.	\$ Each
12	FHCNTU12	248.0	224.00
14	FHCNTU14	289.0	262.00
16	FHCNTU16	331.0	299.00

CANTILEVER CROSS BRACE KIT

Length (in.)	Model	Shpg. Wt.	\$ Each
60	FHCNTX60	65.0	56.00

PALLET RACKS

This multipurpose rack is the most common form of warehouse storage systems. The structural steel construction is configured to handle virtually any product and better utilize warehouse vertical storage space.

- ◆ Bolted construction
- ◆ Structural steel design enables storage of high weight capacities
- ◆ Protects and organizes inventory in high abuse environments
- ◆ Wire mesh decking, fork entry bars and pallet support bars available



BEAMS

Size	Load Capacity per pair of Beams	Model	Shpg. Wt.	\$ Each
8' x 4"	5000 lbs.	FHBM84	23.0	21.00
9' x 4"	4500 lbs.	FHBM94	26.0	24.00
10' x 4"	4000 lbs.	FHBM104	28.0	27.00

FRAMES

Height (in.)	Depth (in.)	Model	Shpg. Wt.	\$ Each
96	42	FHU842	67.0	43.00
120	42	FHU1042	82.0	54.00
144	42	FHU1242	96.0	64.00
168	42	FHU1442	110.0	75.00
192	42	FHU1642	121.0	86.00
120	48	FHU1048	85.0	64.00
144	48	FHU1248	100.0	77.00
168	48	FHU1448	115.0	89.00
192	48	FHU1648	130.0	102.00

Max Load Capacity 20,000 lbs.

PALLET RACK WIRE DECKING

Height (in.)	Depth (in.)	Model	Shpg. Wt.	\$ Each
46	42	FHWD462	30.0	25.00
52	42	FHWD522	36.0	27.00
58	42	FHWD582	38.0	30.00
46	48	FHWD468	36.0	26.00
52	48	FHWD528	43.0	28.00
58	48	FHWD588	46.0	31.00

CUSTOM PROJECTS

Full-House designs and manufactures custom material handling items, such as racks, carts and tables. Call today with your custom project.

DOUBLE SIDED HORIZONTAL BAR RACK

Arms extend and act as dividers creating bays of storage. Nine arm levels of varying lengths can store material up to 10 feet long. Aligning two units next to each other will allow for the storage of longer material. Arm edges are sloped upward to prevent roll-offs. Arms are welded at 6" increments with 7" between levels. Total rack capacity is an 2,600 lbs. evenly distributed load. Overall height - 84"



Overall Width	Overall Depth	Arm Levels	Distance Between Levels	Model	Shpg. Wt.	\$ Each
30"	30"	9	7"	FH50500	110.0	315.00

SINGLE/ DUAL SIDED BAR STOCK TREES

Starter unit includes two uprights and one set of cross braces. Storage room is increased when the add-on unit is ordered. Add-on unit consists of one upright and one set of cross braces for joining to the starter set. Capacity is 2,000 pounds per level and 500 pounds per arm. Distance between levels is 10". There are 6 arm levels. Choose either single sided or double sided rack.

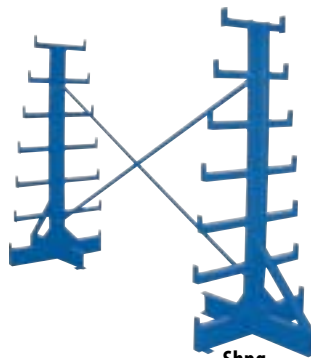

Style	Description	Overall Size (WxDxH)	Model	Shpg. Wt.	\$ Each
Single Sided	Starter Unit	84"x38-1/2"x80-1/2"	FH50501	253.0	360.00
Double Sided	Starter Unit	84"x38-1/2"x80-1/2"	FH50502	322.0	450.00
Single Sided	Add-On Unit	84"x38-1/2"x80-1/2"	FH50503	120.0	205.00
Double Sided	Add-On Unit	84"x38-1/2"x80-1/2"	FH50504	155.0	240.00

VARIABLE HEIGHT SHEET RACKS

These sheet racks are perfect for use with multiple sizes of material. Four different bays with heights from 16" to 42" increase visibility of stored materials. Available in all welded steel construction, FH50505, or bolt together construction, FH50506. Bolt together units feature adjustable-width uprights. Capacity per bay is 1,500 lbs.



Overall Size (WxDxH)	Number of Bays	Distance Between Bays	Model	Shpg. Wt.	\$ Each
48"x36"x42"	4	6"	FH50505	200.0	395.00
48"x36"x42"	4	6"	FH50506	190.0	410.00

VARIABLE HEIGHT SHEET RACKS

Designed for the vertical storage of sheet goods. Standard unit comes with four bays. Intermediate floor bracing gives added steel support while keeping material off the floor. Capacity per bay is 1,500 lbs.

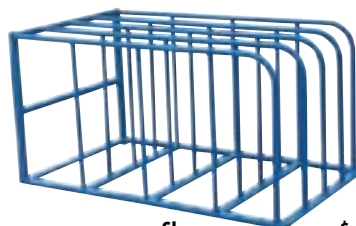

Overall Size (WxDxH)	Number of Bays	Distance Between Bays	Model	Shpg. Wt.	\$ Each
50"x84"x44"	4	10"	FH50507	400.0	705.00

VERTICAL STORAGE RACK

Each rack has (4) bays that measure 10" wide each and handle a capacity of 1,500 lbs. per bay. A restraint chain securely holds items in storage bays.



Overall Size (WxDxH)	Model	Shpg. Wt.	\$ Each
48"x24"x60"	FH50508	234.0	370.00

VERTICAL BAR RACK

Designed for storage of long parts close to the worksite. Long pieces stack vertically while shorter parts are kept horizontal on the three pan shelves. Designed to be placed up against a wall. Rack has 3 bays 21" apart. Includes a restraint chain to hold items in each bay. The capacity is 3,000 lbs. when evenly distributed.



Overall Size (WxDxH)	Model	Shpg. Wt.	\$ Each
39"x24"x84"	FH50509	144.0	180.00

HORIZONTAL SHEET RACK

Designed for storage of sheet goods and similar materials. Flat storage reduces warping of thin materials. Five shelf design allow for generous storage of multiple thickness materials. Distance between shelves is 9 1/2". All welded steel frame allows for 2,000 pound capacity per shelf. Four sided access when using 4' x 8' sheet or smaller.



Overall Size (WxDxH)	Model	Shpg. Wt.	\$ Each
55"x48"x103"	FH50510	564.0	1010.00

INTERNESTABLE STACKABLE RACKS

Space saving storage is what this rack is all about. The 4" under clearance allows for easy fork truck accessibility. Units can stack up to 20 feet high. Sturdy, welded construction gives these units an abundance of strength and stability. Special redundant stacking systems allows units to be inter-nested for space saving storage when not in use. Flared posts, pintle and target, make it easy to line up units for stacking.

Usable (WxDxH)	Overall Size (WxDxH)	Capacity (lbs.)	Model	Shpg. Wt.	\$ Each
48"x42"x48"	57"x46"x58"	4,000	FH50511	288.0	335.00
60"x42"x48"	69"x46"x58"	4,000	FH50512	320.0	370.00
48"x48"x48"	57"x54"x58"	4,000	FH50513	306.0	355.00
60"x48"x48"	69"x54"x58"	4,000	FH50514	340.0	395.00



ECONOMIC MATERIAL RACKS

Model FH50515 is a wall mounted unit with dual 60" high supports. They come with (3) 15" arms and (4) 12" arms. The 15" arms have 9" height clearance and the 12" arms have 7 1/4" clearance. Uniform load capacity is 1,000 pounds. The bright zinc plating provides a long term, attractive appearance. Shipped knockdown with convenient and quick assembly.

Model FH50516 is a self-supporting 66" high A-frame with 8 storage levels. Arms extend up to 12" beyond A-frame. Base dimensions are 60" by 36". Shipped knocked down with convenient and quick assembly. Bright zinc plated.

Description	Height	Capacity (lbs.)	Model	Shpg. Wt.	\$ Each
Wall Mount	60"	1,000	FH50515	25.0	55.00
Self Supporting	60"	2,000	FH50516	70.0	90.00

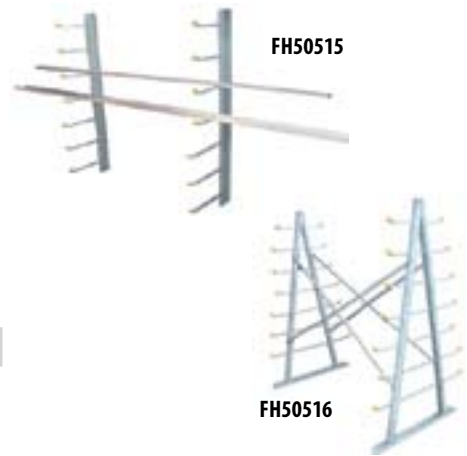

STACKABLE BAR CRADLES

These sturdy, welded steel racks are strong enough to handle heavy loads yet light enough to be set up by one person. Stackable up to five units high. Allows for custom design by choosing length, depth and height of individual storage systems.

Inside Size (WxDxH)	Overall Size (WxDxH)	Capacity (lbs.)	Model	Shpg. Wt.	\$ Each
8"x12"x12"	12"x16"x13 1/2"	2,500	FH50517	21.0	60.00
11"x18"x18"	15"x22"x20 1/2"	5,600	FH50518	46.0	85.00
12"x22"x20"	16"x26"x23 1/2"	7,500	FH50519	72.0	115.00



STAINLESS STEEL SHELVEING

Provide easy access to stored items from all sides. High-quality stainless steel construction is ideal for the commercial or industrial use. Each model includes four adjustable shelves ideal for different height products. Shelves are 18 gauge thick and hold up to 600 pounds each (uniform load). Units ship knock-down and requires assembly.

Shelf Size (WxDxH)	OAL Height	Capacity per Shelf (lbs.)	Model	Shpg. Wt.	\$ Each
18"x36"	74"	600	FH50520	110.0	655.00
18"x48"	74"	600	FH50521	135.0	740.00
24"x36"	74"	600	FH50522	129.0	750.00
24"x48"	74"	600	FH50523	153.0	890.00



MANUAL CAROUSELS



The **Carousel** rotates materials 360 degrees with the assistance of an operator. The carousel may be added to an existing work bench, scissor table or simply placed on the floor. The overall height of the carousel is 2"

Outer Dia. (in.)	Capacity (lbs.)	Model	Shpg. Wt.	\$ Each
18	2,000	FH50524	20.0	255.00
24	2,000	FH50525	26.0	280.00
24	4,000	FH50526	30.0	320.00
30	2,000	FH50527	36.0	315.00
30	4,000	FH50528	40.0	350.00
36	2,000	FH50529	43.0	325.00
36	4,000	FH50530	47.0	365.00
40	2,000	FH50531	48.0	330.00
40	4,000	FH50532	53.0	340.00
40	6,000	FH50533	58.0	415.00
48	2,000	FH50534	58.0	465.00
48	4,000	FH50535	61.0	500.00
48	6,000	FH50536	66.0	550.00
60	2,000	FH50537	72.0	505.00
60	4,000	FH50538	76.0	550.00
60	6,000	FH50539	79.0	610.00
72	2,000	FH50540	86.0	615.00
72	4,000	FH50541	90.0	660.00
72	6,000	FH50542	95.0	720.00

SPECIAL CAROUSEL OPTIONS

Description	Model	Shpg. Wt.	\$ Each
Elevated Base - 12"H	FH50543	345.0	445.00
Elevated Base - 24"H	FH50544	460.0	585.00
1/4" Thick top plate 48" Dia. Round	FH50545	253.0	245.00
1/4" Thick top plate 48"x48" Square	FH50546	253.0	245.00
Stainless Steel Rings (40" Dia. only)	FH50547	54.0	255.00
Manual Brake (field installed)	FH50548	5.0	85.00
Hand operated locking detent (factory installed)	FH50549	10.0	120.00
Foot operated locking detent (factory installed)	FH50550	11.0	160.00

ADJUSTABLE WORK MATE STANDS

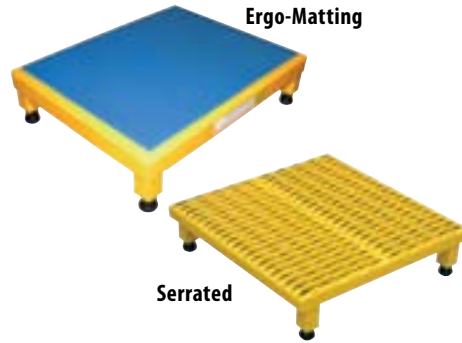

Ergonomic matting deck style provides comfort for the operator who stands all day. Simply adjust the legs by screwing them in or out to the desired height.

Serrated Style Work-Mates are built lightweight and affordable. Serrated platform provides traction for wet environments. Height adjustment is 5" to 8." • Capacity is 500 pounds.

Deck Size (WxL)	Model	Shpg. Wt.	\$ Each
Ergo-Matting Deck			
19"x24"	FH51000	25.0	170.00
24"x24"	FH51001	33.0	190.00
19"x36"	FH51002	38.0	210.00
24"x36"	FH51003	44.0	230.00
19"x48"	FH51004	47.0	245.00
24"x48"	FH51005	52.0	270.00
24"x60"	FH51006	63.0	305.00
24"x72"	FH51007	76.0	375.00
24"x96"	FH51008	100.0	490.00
Serrated Deck			
19"x24"	FH51009	22.0	145.00
24"x24"	FH51010	30.0	160.00
19"x36"	FH51011	35.0	175.00
24"x36"	FH51012	40.0	185.00
19"x48"	FH51013	44.0	195.00
24"x48"	FH51014	49.0	205.00
24"x60"	FH51015	59.0	225.00
24"x72"	FH51016	72.0	280.00
24"x96"	FH51017	94.0	370.00

ADJUSTABLE STEP MATE STANDS



This **Serrated Step Style** brings the worker up to the optimum working height with an economical platform. Lowered step is 6" to 10 1/2". Upper step is 7" higher than lower step. Capacity 500 lbs.

OAL Size (WxD)	Model	Shpg. Wt.	\$ Each
24" x 24"	FH51018	25.0	190.00
36" x 24"	FH51019	33.0	205.00
48" x 24"	FH51020	38.0	225.00

COMMERCIAL SPRING LOADED LADDERS

An attractive and economical alternative to the traditional warehouse rolling ladder, this sleek design provides maximum safety and convenience. 20" wide. Choose color: yellow, white or blue.

# of Steps	Top Step Height (in.)	OAL Depth (in.)	Model*	Shpg. Wt.	\$ Each
1	10	16	FH41200	16.0	130.00
2	19 1/4	23	FH41201	24.0	140.00
3	28 1/2	30	FH41202	39.0	200.00
4	38	35	FH41203	47.0	235.00
5	47 1/2	40	FH41204	56.0	270.00

*Yellow, White or Blue

ALUMINUM TELESCOPIC LADDERS

Ideal when storage space is limited. Ladders extend in 12" increments. Bumper guards prevent walls and floors against scratches. Meets OSHA and ANSI Specs.

Extended Steps	Closed Size (W x D x H) (in.)	Step Depth	Capacity (lbs.)	Model	Shpg. Wt.	\$ Each
6 in. - 10 ft.	18-1/2 x 2-3/4 x 29	1-1/2"	225	FH41400	22.0	215.00
6 in. - 12 ft.	19-1/4 x 3 1/2 x 32	1-1/2"	225	FH41401	28.0	225.00

DOOR CART

Great for delivery or in shop moving! The hand held Door Cart is ergonomically designed for quickly and easily moving doors or other large but slender items down small aisles or through doorways.

- ◆ 750 lbs. Max Capacity
- ◆ 10" x 2.5" Solid Rubber Casters
- ◆ Pneumatic Wheel



Model	Shpg. Wt.	\$ Each
FH41500	72.0	250.00

HEAVY DUTY PANEL CART

You get double your money's worth with this Heavy Duty Panel Cart. Not only is it the perfect panel cart for transporting plywood, drywall, paneling, doors, etc.; it transforms into a platform truck when you remove the 27" high support rails.

- ◆ 4,000 lbs. Max Capacity
- ◆ 5" x 2" Poly-On-Steel Casters



Deck Size (WxD)	Model	Shpg. Wt.	\$ Each
29-1/2"x36"	FH41501	247.0	490.00

A-FRAME CARTS

If you need to move bulky sheets of material such as drywall, plywood, paneling or sheets of metal, you need the heavy duty A-Frame Cart.

- ◆ 2,000 lbs. Max Capacity
- ◆ 5" x 2" Poly-On-Steel Casters



OAL Size (WxD)	Model	Shpg. Wt.	\$ Each
24"x36"	FH41520	195.0	310.00
24"x48"	FH41521	215.0	325.00
30"x48"	FH41522	230.0	335.00
30"x60"	FH41523	258.0	350.00
36"x72"	FH41524	287.0	390.00

HARDWOOD DOLLIES

Transport boxes, crates or supplies with these rugged dollies. Units maneuver on four swivel hard rubber casters. Assembly required. Optional Pull Strap or Hook available.

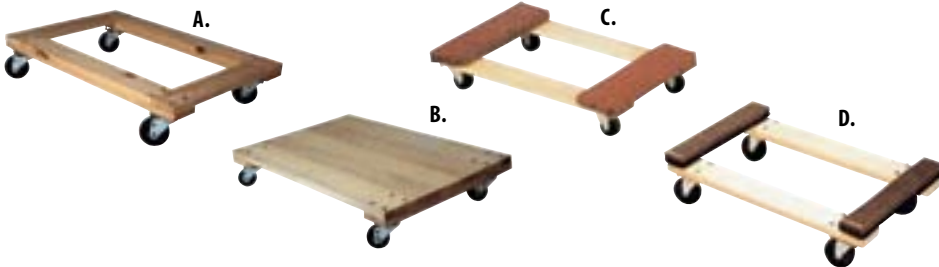

Deck Size (WxL)	Deck Height	Capacity (lbs)	Caster Size	Model	Shpg. Wt.	\$ Each
A. Open Deck Hardwood Dollies						
16"x24"	5-1/2"	900	3"x 1-1/4"	FH41540	19.0	45.00
24"x36"	5-1/2"	900	3"x 1-1/4"	FH41541	24.0	50.00
16"x24"	6-3/4"	1,200	4"x 1-1/4"	FH41542	20.0	50.00
24"x36"	6-3/4"	1,200	4"x 1-1/4"	FH41543	26.0	55.00
B. Solid Deck Hardwood Dollies						
16"x24"	5-1/2"	900	3"x 1-1/4"	FH41544	24.0	50.00
24"x36"	5-1/2"	900	3"x 1-1/4"	FH41545	35.0	55.00
16"x24"	6-3/4"	1,200	4"x 1-1/4"	FH41546	31.0	55.00
24"x36"	6-3/4"	1,200	4"x 1-1/4"	FH41547	42.0	60.00
C. Carpet End Hardwood Dollies						
16"x24"	5-3/4"	900	3"x 1-1/4"	FH41548	22.0	25.00
24"x36"	5-3/4"	900	3"x 1-1/4"	FH41549	29.0	35.00
D. Rubber End Hardwood Dollies						
18"x30"	7"	1,200	4"x 1-1/4"	FH41550	20.0	30.00

DOLLY CONVERTER

Transform your dolly into a panel cart by attaching these steel converter arms to your existing hardwood dolly. Ideal lightweight moving solution for industrial and commercial use.

- ◆ 250 lbs. Max Capacity
- ◆ 12" x 37" Size



Model	Shpg. Wt.	\$ Each
FH41590	26.0	80.00

HARDWOOD DOLLIES ACCESSORIES

Description	Model	Shpg. Wt.	\$ Each
4' nylon loop pull strap	FH41591	1.0	10.00
4' metal hook	FH41592	3.0	30.00

DOCKPLATES & DOCKBOARDS

ALUMINUM DOCKPLATES

- ◆ Speed up truck loading and unloading.
- ◆ Span the opening between dock and trailer to allow safe movement in and out.

Automatically compensate for height difference between dock and truck bed. High strength, lightweight aluminum alloy nonskid tread plate. Zinc-plated handle on each side for portability. Zinc-plated locking legs to secure dockplate when in use. Meet OSHA requirements.

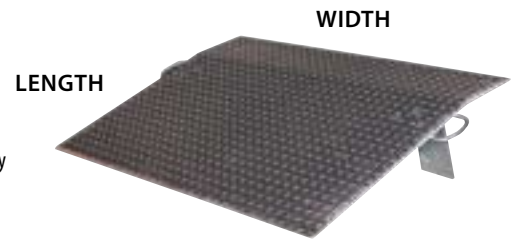

Width (in)	Length (in.)	Load Capacity (lbs.)	Thickness (in.)	Max Height Difference (in.)	Model	Shpg. Wt.	\$ Each
30	48	1,400	3/8	7	FH41600	74.0	353.00
36	24	3,600	3/8	3	FH41601	43.0	266.00
36	30	3,000	3/8	4	FH41602	58.0	228.00
36	36	2,500	3/8	5	FH41603	56.0	387.00
36	48	1,900	3/8	7	FH41604	85.0	406.00
42	30	3,300	3/8	4	FH41605	64.0	248.00
48	24	5,200	3/8	3	FH41606	60.0	235.00
48	36	3,500	3/8	5	FH41607	77.0	369.00
48	36	5,300	1/2	5	FH41608	108.0	448.00
48	48	2,600	3/8	7	FH41609	107.0	445.00
48	48	3,800	1/2	7	FH41610	125.0	600.00
48	60	1,800	3/8	9	FH41611	126.0	577.00
60	36	4,100	3/8	5	FH41612	101.0	445.00
60	36	6,600	1/2	5	FH41613	121.0	581.00
60	48	2,900	3/8	7	FH41614	120.0	574.00
72	30	9,500	1/2	4	FH41615	127.0	588.00

MATERIAL HANDLING

STEEL TRUCK DOCKBOARDS

- ◆ Bend is 11° and 9" from Beveled Edge? Legs are 12" from edge
- ◆ Treadplate Design Ensures Positive Traction
- ◆ Designed for Medium/High Traffic Application

Constructed of high strength (55,000 PSI) Steel for long life. Beveled edges on both ends permit smooth entry and exit. Deck is checkered for safe efficient use. Locking legs minimize ramp movement. Available in widths of 60" and 72". Standard with lever lift for help with portability. Locking legs are uneven to allow the dockboard to sit canted for easier pickup by forklifts, when picking off the floor.

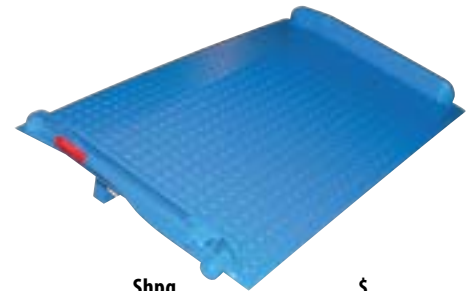

Width (in)	Length (in.)	Load Capacity (lbs.)	Max Height Difference (in.)	Model	Shpg. Wt.	\$ Each
60	36	10,000	5	FH41616	261.0	520.00
60	48	10,000	7	FH41617	368.0	624.00
72	36	10,000	5	FH41618	326.0	560.00
72	48	10,000	7	FH41619	426.0	798.00
60	48	15,000	7	FH41620	426.0	900.00
60	60	15,000	10	FH41621	537.0	1048.00
60	72	15,000	12	FH41622	635.0	1153.00
72	36	15,000	5	FH41623	347.0	871.00
72	48	15,000	7	FH41624	496.0	974.00
72	54	15,000	8 1/2	FH41625	575.0	1083.00
72	60	15,000	10	FH41626	698.0	1140.00
72	60	20,000	10	FH41627	723.0	1280.00

ALUMINUM TRUCK DOCKBOARDS WITH STEEL SAFETY CURBS

- ◆ Beveled Edges for Smooth Entry & Exit
- ◆ Treadplate Design Ensures Positive Traction
- ◆ Bend is 11° and 9° from Beveled Edge
- ◆ Legs are 12" from Beveled Edge

This dockboard is designed for portability and safety. Deck is made of tough high strength aluminum treadplate. Safety curbs are painted yellow and are constructed of structural steel with cast tapered ends. Steel legs are bolted for increased durability. Canted locking legs for easier fork truck portability. Manufactured in compliance of OSHA.

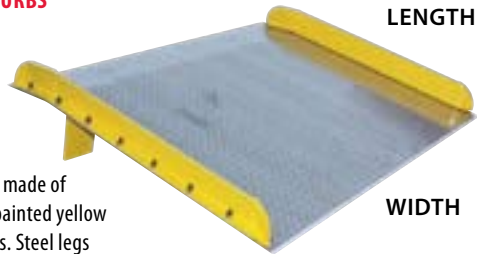

Width (in.)	Length (in.)	Load Capacity (lbs.)	Max Height Difference (in.)	Model	Shpg. Wt.	\$ Each
60	36	10,000	5	FH41628	103.0	542.00
60	48	10,000	7	FH41629	145.0	694.00
60	60	10,000	10	FH41630	169.0	847.00
60	72	10,000	12	FH41631	227.0	1008.00
72	48	10,000	7	FH41632	175.0	842.00
60	36	15,000	5	FH41633	121.0	594.00
60	48	15,000	7	FH41634	161.0	873.00
60	60	15,000	10	FH41635	219.0	1062.00
72	48	15,000	7	FH41636	195.0	857.00
72	60	15,000	10	FH41637	260.0	1275.00
60	36	20,000	5	FH41638	125.0	643.00
72	36	20,000	5	FH41639	147.0	724.00
72	48	20,000	7	FH41640	210.0	1020.00
72	60	20,000	10	FH41641	301.0	1590.00

PREMIUM TRUCK SCISSOR DOCK LIFT

Save time and reduce man-hours where there are no docks. Includes beveled toe-guards and electric toe-guards around perimeter of platform. External 6.5 HP 208-230/460V, 3-phase, 60 Hz motor may be located up to 8 feet away from lift. OSHA and ANSI compliant.

- ◆ Capacity: 5,000 lbs.
- ◆ Platform Size: 72" W x 96" L
- ◆ Overall Frame: 62" W x 93" L



Height Range (in.)	Model	Shpg. Wt.	\$ Each
8 - 68	FH41900	3780.0	6399.00

STEEL YARD RAMPS

SAFETY FEATURES

- ◆ Positive Steel Traction Grating
- ◆ Safety Locking Chains
- ◆ 9" Steel Wheels
- ◆ 4" high safety curbs
- ◆ Manual Hand Crank System for Height Adj.

*Must ship flat bed truck.



STEEL YARD RAMP OPTIONS

Description	Model	Shpg. Wt.	\$ Each
Fork lift pick-up slots	FH41890	460.0	461.00
Tow Loop	FH41891	60.0	129.00
Tow Bar Hitch	FH41892	72.0	175.00
42" high handrails w/21" midrail	FH41893	12 per ft.	14.00

Capacity (lbs.)	Overall Ramp Width (in.)	Usable Ramp Width (in.)	Length (ft.)	Model	Shpg. Wt.	\$ Each
16,000	72	67	30	FH41800	3780.0	7,687.00
16,000	84	78	30	FH41801	4095.0	8,322.00
16,000	72	67	36	FH41802	4725.0	8,378.00
16,000	84	78	36	FH41803	5040.0	9,390.00
20,000	73	67	30	FH41804	4515.0	8,316.00
20,000	85	78	30	FH41805	4830.0	9,331.00
20,000	73	67	36	FH41806	5565.0	9,386.00
20,000	85	78	36	FH41807	5985.0	10,594.00
25,000	73	67	30	FH41808	4725.0	8,728.00
25,000	85	78	30	FH41809	5040.0	9,771.00
25,000	73	67	36	FH41810	5880.0	9,880.00
25,000	85	78	36	FH41811	6300.0	11,527.00
30,000	73	67	30	FH41812	4935.0	9,386.00
30,000	85	78	30	FH41813	5250.0	10,923.00
30,000	73	67	36	FH41814	6300.0	11,142.00
30,000	85	78	36	FH41815	6720.0	12,514.00

MATERIAL HANDLING

FULL FEATURED PALLET TRUCK

The full featured ergonomic pallet truck is an economical way for one person to move heavy pallet loads without the use of a fork truck.

- ◆ Sloped and rounded fork nose design
- ◆ User friendly entry and exit rollers
- ◆ Service range is 2-7/8" lowered to 7-3/4" raised
- ◆ Forks are 48" long and 6-3/4" wide
- ◆ 6° articulating wheel assembly for uniform axle loading on uneven floors



Capacity (lbs.)	Overall Fork Dim.	Service Range	Model	Shpg. Wt.	\$ Each
5,500	27"Wx48"L	2-7/8"-7-3/4"	FH42000	280.0	395.00
5,500	20"Wx48"L	2-7/8"-7-3/4"	FH42001	225.0	395.00

OPTIONS FOR FH42000 ONLY (factory installed)

Description	Model	\$ Each
Hand Brake (Depress hand brake to stop)	FH42020	46.00
"Dead Man" Hand Brake (Depress hand brake to move)	FH42021	141.00
Foot Brake Kit	FH42022	26.00

SIDE WINDER PALLET TRUCK

This versatile Pallet Truck retains all the quality workmanship of a standard pallet truck in addition to providing lateral movement.

- ◆ Move Long Loads Down Narrow Aisles
- ◆ Moves FORWARD, BACKWARD, LEFT, and RIGHT
- ◆ Capacity is 3,000 pounds



Capacity (lbs.)	Overall Fork Dim.	Service Range	Model	Shpg. Wt.	\$ Each
3,000	27"Wx48"L	3-1/2" - 8"	FH42002	311.0	425.00

FORK EXTENSIONS

Provide Extra Support needed to lift long or large objects with at fork truck. Steel retaining strap prevents fork extensions from sliding off forks during use. OSHA reg. require that extensions are not more than 150% of the existing fork length. Max capacity is 4,000 lbs. distributed evenly.

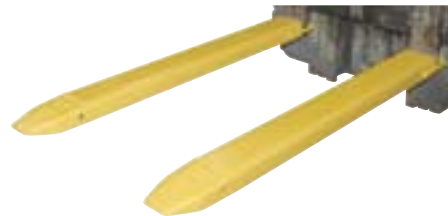

Accommodates Fork Width (in.)	Fork Extension Inside Width (in.)	Length (in.)	Max Fork Thickness (in.)	Model	Shpg. Wt.	\$ Each
4	4 1/2	63	2	FH42500	135.0	222.00
4	4 1/2	72	2	FH42501	157.0	239.00
4	4 1/2	84	2	FH42502	157.0	257.00
5	5 1/2	63	2	FH42503	151.0	230.00
5	5 1/2	72	2	FH42504	155.0	249.00
5	5 1/2	84	2	FH42505	189.0	266.00
6	6 1/2	63	2 1/2	FH42506	165.0	261.00
6	6 1/2	72	2 1/2	FH42507	166.0	285.00
6	6 1/2	84	2 1/2	FH42508	199.0	311.00

PALLET TRUCK CADDY

This economical product will convert a standard pallet truck into a portable workstation in minutes. Easily attaches to virtually any type of pallet truck with hardware included.



Model	Shpg. Wt.	\$ Each
FH42010	5.0	95.00

FORK EXTENSION STORAGE RACK

Install or remove fork extensions without lifting, pushing or getting off the fork truck. Forks not included. Min. fork length 60".



Overall Size (in.)	Model	Shpg. Wt.	\$ Each
40 x 46 x 54	FH42590	135.0	268.00

"P" HANDLE HAND TRUCKS

The "P" style hand trucks are ideal for transporting heavy and awkward loads. These trucks work well for the user that needs to free up one hand. The "P" shaped handle makes the truck easy to steer and maneuver.



FH42101



FH42102



FH42104

Capacity (lbs.)	Overall Size	Nose Plate (WxD)	Model	Shpg. Wt.	\$ Each
10" x 2" Hard Rubber Wheels					
500	21"x18"x52"	13-3/4"x7-1/2"	FH42100	51.0	50.00
600	22"x19"x52"	22"x7"	FH42101	64.0	55.00
10" x 3-1/2" Pneumatic Wheels					
500	21"x18"x52"	13-3/4"x7-1/2"	FH42102	37.0	40.00
600	22"x19"x52"	22"x7"	FH42103	51.0	45.00
13" x 4" Pneumatic Wheels					
600	21"x18"x52"	13-3/4"x7-1/2"	FH42104	37.0	55.00

DUAL DIRECTIONAL & HANDLE HAND TRUCKS

The **Dual Directional Hand Truck** works great as a standard two-wheel hand truck or as a panel cart. This unit allows the user to transport loads forward/backward or left/right. 8" x 2" Mold-on-rubber wheels.

Maximize control for different loads with heavy duty **Dual Handle Hand Trucks**. Transport loads smoothly and evenly over rough or uneven floors. Ships knockdown. Solid rubber wheels will never go flat. 10" x 3-1/2" pneumatic wheels.



FH42105



FH42106

Capacity (lbs.)	Overall Size	Nose Plate (WxD)	Model	Shpg. Wt.	\$ Each
600	20"x18"x51"	3-1/2" - 8"	FH42105	55.0	85.00
500	21"x17-1/2"x44-1/2"	13-3/4"x6-1/2"	FH42106	36.0	50.00

PLATFORM TRUCKS

HARDWOOD DECK W/STEEL FRAME



- ◆ 9" Platform Height
- ◆ Mold-On-Rubber Casters
- ◆ 1,600 lbs. Capacity

Deck Size (in.)	Model	Shpg. Wt.	\$ Each
24"x48"	FH42205	131.0	245.00
27"x54"	FH42206	138.0	250.00
30"x60"	FH42207	160.0	260.00
36"x72"	FH42208	173.0	270.00

HARDWOOD PLATFORM TRUCKS

- ◆ Mold-on-Rubber Wheels, Swivel casters
- ◆ Removable smooth, U-curved tubular steel handle fits into pockets at deck's steering end
- ◆ Capacity- 1,600 lbs.



Platform Size (In.)	Model	Shpg. Wt.	\$ Each
24"x48"	FH42209	125.7	289.00
27"x54"	FH42210	124.0	309.00
30"x60"	FH42211	131.0	329.00

TILT-TYPE HEAVY-DUTY ALL WOOD PLATFORM TRUCK

- ◆ Hardwood construction reinforced with steel
- ◆ Load wheels are 12 x 2 1/2" on a 1" Dia. axel
- ◆ 6 x 2" end casters, 2,200 lbs. Load Capacity
- ◆ Offers extreme maneuverability.



Platform Size (In.)	Model	Shpg. Wt.	\$ Each
48"x30"	FH42212	180.0	589.00
60"x30"	FH42213	225.0	599.00

PORTABLE STEEL HOPPERS

Portable Steel Hoppers make handling waste and bulk material safer and more convenient. Fork truck entry tubes make dumping into large containers easy. Foot operated caster lock is included. Capacity is 2,000 lbs.



Size (HxWxD)	Capacity (lbs)	Gauge of Steel	Volume Cubic Yards	Model	Shpg. Wt.	\$ Each
37-3/4" x 34-1/4" x 52-5/8"	2,000	12	1/2	FH45511	251.0	535.00
47-1/8" x 58-1/4" x 52-1/8"	2,000	12	1	FH45512	393.0	615.00
49-3/4" x 58-1/4" x 52-3/8"	2,000	12	1.5	FH45513	461.0	645.00

LOW PROFILE PARTS HOPPER

This unique product has been designed to function as a parts hopper that may be dumped with the assistance of a fork truck. The low-profile design (only 18" high) allows the hopper to be placed underneath machinery to be used as a catch basin for parts. The newly designed hopper reduces the hazards, inconveniences and time when collecting parts off the floor.



Overall (WxDxH)	Capacity (lbs)	Volume Cubic Yards	Model	Shpg. Wt.	\$ Each
48-1/2" x 57" x 18"	2,000	1/2	FH45514	384.0	540.00

STEEL CANTILEVER STOCKPICKER TRUCK

This unique cantilever design allows for oversized packages to fit conveniently on the bottom shelf without restricting access to the packages.

- ◆ 28.25" Shelf Clearance • 35" Top Shelf Height
- ◆ 440 lbs. Total Capacity • 110 lb. Shelf Capacity
- ◆ 4" x 2" Casters
- ◆ Spring Loaded Ladder



Bottom Shelf Size (in.)	Model	Shpg. Wt.	\$ Each
20-1/2" x 41"	FH45500	384.0	350.00

ERGO-HANDLE CARTS

The Ergo-Handle Cart is constructed of heavy duty steel to handle loads up to 4,000 lbs.

- ◆ 8" x 2" Phenolic Casters
- ◆ 22" Shelf Clearance • 36" Top Shelf Height
- ◆ Bolt on ergo handle



Platform Size (in.)	Model	Shpg. Wt.	\$ Each
24" x 36"	FH45501	225.0	320.00
24" x 48"	FH45502	253.0	350.00
24" x 60"	FH45503	275.0	375.00
24" x 72"	FH45504	280.0	400.00

STEEL STOCKPICKER TRUCKS

Combine the mobility of a cart with the versatility of a step ladder with our Stockpicker Trucks. Cart can handle 1,000 lbs. or 550 lbs. per shelf.

- ◆ 2 Shelf Unit 27" Shelf Clearance
- ◆ 3 Shelf Unit 13.5" Shelf Clearance
- ◆ 35" Top Shelf Height



Bottom Shelf Size (in.)	Model	Shpg. Wt.	\$ Each
2-Shelf Units			
22"x36"	FH45505	200.0	360.00
28"x40"	FH45506	210.0	385.00
28"x48"	FH45507	225.0	410.00
3-Shelf Units			
22"x36"	FH45508	260.0	385.00
28"x40"	FH45509	275.0	410.00
28"x48"	FH45510	298.0	435.00

LOW PROFILE 90° SELF-DUMPING STEEL HOPPERS

Units have a full 90° dump angle with a cushioned rubber bumper stop. The low profile design is essential for convenient loading. Dumping with a forklift is quick and simple. A safety restraint is provided to secure the hopper to the forklift. 22" L Usable fork pockets measure 7" W x 2" H



Volume Cubic Yards	Capacity (lbs.)	Overall (WxDxH)	Fork Pocket Centers	Model	Shpg. Wt.	\$ Each
Light Duty • 12 Gauge Steel						
1/4	2,000	25"x46"x18-1/4"	11-1/2"	FH45010	219.0	420.00
1/2	2,000	25"x51-1/4"x28"	11-3/4"	FH45011	256.0	475.00
1	2,000	49"x51-1/4"x28"	21-3/4"	FH45012	347.0	565.00
1-1/2	2,000	49"x51-3/4"x41"	21-3/4"	FH45013	486.0	645.00
Medium Duty • 10 Gauge Steel						
1/4	4,000	25"x46"x18-1/4"	11-1/2"	FH45014	219.0	435.00
1/2	4,000	25"x51-1/4"x28"	11-3/4"	FH45015	256.0	495.00
1	4,000	49"x51-1/4"x28"	21-3/4"	FH45016	395.0	575.00
1-1/2	4,000	49"x51-1/4"x41"	21-3/4"	FH45017	463.0	715.00
Heavy Duty • 8 Gauge Steel						
1/4	4,500	25"x46"x18-1/4"	11-1/2"	FH45018	219.0	455.00
1/2	4,500	25"x51-1/4"x28"	11-3/4"	FH45019	282.0	520.00
1	4,500	49"x51-1/4"x28"	21-3/4"	FH45020	462.0	645.00
1-1/2	4,500	49"x51-1/4"x41"	21-3/4"	FH45021	540.0	810.00

70° SELF-DUMPING STEEL HOPPERS WITH BUMPER RELEASE

Hopper automatically dumps when bumper release contacts side of dumpster. Hopper returns to an upright and locked position automatically after it dumps. Also includes a cable that may be operated from the seat of the fork truck to manually dump the hopper. Usable fork pockets measure 7-1/2" W x 2-1/2" H

STYLE D

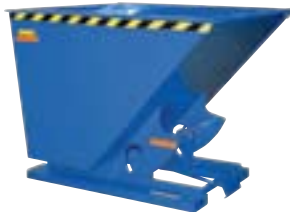

Volume Cubic Yards	Capacity (lbs)	Overall (WxDxH)	Fork Pocket Centers	Model	Shpg. Wt.	\$ Each
Light Duty • 12 Gauge Steel						
1	2,000	41-1/2"x60-1/2"x43"	18"	FH45022	524.0	600.00
2	2,000	56-1/2"x69"x52"	28"	FH45023	725.0	720.00
3	2,000	81-3/4"x69"x52"	28"	FH45024	991.0	1220.00
Medium Duty • 10 Gauge Steel						
2	4,000	56-1/2"x69"x52"	28"	FH45025	725.0	780.00
3	4,000	81-3/4"x69"x52"	28"	FH45026	991.0	1300.00
Heavy Duty • 8 Gauge Steel						
1/3	6,000	26"x49-1/4"x38-1/4"	18"	FH45027	412.0	515.00
1/2	6,000	33-1/2"x49-1/4"x38-1/4"	18"	FH45028	452.0	565.00
3/4	6,000	31-1/2"x60-1/2"x43"	18"	FH45029	560.0	600.00
1	6,000	41-1/2"x60-1/2"x43"	18"	FH45030	622.0	730.00
1 1/2	6,000	43-1/2"x69"x52"	28"	FH45031	747.0	860.00
2	6,000	56-1/2"x69"x52"	28"	FH45032	777.0	980.00
2 1/2	6,000	69-1/2"x69"x52"	28"	FH45033	900.0	1230.00
3	6,000	81-3/4"x69"x52"	28"	FH45034	991.0	1300.00

CASTERS FOR SELF-DUMPING HOPPERS

Transport loads with portable hoppers. Qty. 4 per order.



Caster Size	Capacity (lbs)	Model	Shpg. Wt.	\$ Each
Semi-Steel				
6"x2"	4,800	FH45047	33.0	180.00
8"x2"	4,800	FH45048	42.0	195.00
Mold-On-Rubber				
6"x2"	2,400	FH45049	28.0	200.00
8"x2"	2,400	FH45050	37.0	205.00
Poly-On-Steel				
6"x2"	4,800	FH45051	33.0	215.00
8"x2"	4,800	FH45052	42.0	250.00

HEAVY-DUTY POLY LIDS FOR SELF-DUMPING HOPPERS

Keep the contents of hoppers out of sight for a cleaner appearance with our new Hopper Covers.

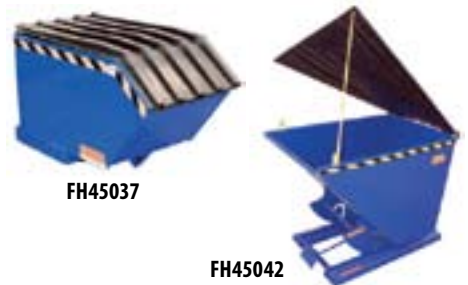

For Use W/Size	For Use W/ Style	Model	Shpg. Wt.	\$ Each
1/4	H	FH45035	7.0	90.00
1/2	H	FH45036	8.0	105.00
1	H	FH45037	16.0	125.00
1-1/2	H	FH45038	16.0	155.00
1/3	D	FH45039	7.0	90.00
1/2	D	FH45040	8.0	110.00
3/4	D	FH45041	9.0	120.00
1	D	FH45042	10.0	125.00
1-1/2	D	FH45043	14.0	150.00
2*	D	FH45044	16.0	165.00
2-1/2*	D	FH45045	18.0	185.00
3*	D	FH45046	20.0	205.00

* Two Piece Design

TRUCK MOUNTED STRAP WINCHES

- ◆ Tightens down loads to minimize shifting
- ◆ Weld or bolt-on design
- ◆ Low-Profile design available
- ◆ Accommodates 4" straps up to 20' long



Description	Overall Size	Model	Shpg. Wt.	\$ Each
Weld On Winch	3-1/2"x7-3/4"x6-1/4"	FH46800	12.0	21.00
Bolt On Winch	3-1/2"x7-3/4"x6-1/4"	FH46801	14.0	25.00
Multi-task Winch Bar	1-1/4"Dx36-1/2"L	FH46802	7.0	17.00
Painted Winch Bar	1-1/4"x33"	FH46803	5.0	15.00
30 FT. Strap	4"Wx30'L	FH46804	7.0	21.00

* Accommodates 4" wide by 30 Foot Long Straps

SEMI-AUTOMATIC STRETCH WRAP MACHINES

Increase productivity in the shipping department or at the end of a production line. Easy to operate simply depress the foot pedal and manually move the mast up and down. Unit comes with one film rod with special spacers that can be used with any height roll of stretch wrap material between 10" and 20". Some assembly required. 4,000 lbs. capacity. The **Approach Ramp** option allows the operator to load and unload with machine with a pallet truck. The **Powered Mast** option is available with a 24V hand control to work those taller loads.



Turntable Dia.	Turntable Height	Max. Load Dia.	Max. Load Height	Model	Shpg. Wt.	\$ Each
48"	2-3/8"	76"	78"	FH46500	665.0	3615.00

STRETCH WRAP MACHINE ACCESSORIES

Description	Model	Shpg. Wt.	\$ Each
Powered Mast Option (Factory Installed)	FH46501	30.0	1855.00
48"Wx36"Lx2-3/8"H Approach Ramp (for electric pallet trucks)	FH46502	223.0	325.00
48"Wx48"Lx2-3/8"H Approach Ramp (for manual pallet trucks)	FH46503	253.0	430.00

HAND HELD STRETCH WRAPPER

These hand held, lightweight, freewheeling dispensers maintain precision tension control assuring a tight, smooth application. Ergonomic design reduces both bending and fatigue. Now even the bottom row can be wrapped as tightly as the top with help from its ergonomic foam bent handle. Accommodates rolls up to 8" in diameter.



INTERTAPE® STRETCH FLEX™

Blown film stretches to create a tight band, sticks only to itself, and leaves no adhesive residue. Includes two rolls and one handle.

Description	Roll Width	Core Size	Model	Shpg. Wt.	\$ Each
Round Style Tightening Grip	12" to 20"	2" to 3"	FH46601	6.0	39.00
Bicycle Style Tightening Grip	12" to 20"	1/2", 2" & 3"	FH46600	6.0	36.00
Intertape® Stretch Flex® .8 Gauge	12"	1500" ft.	FH46602	6.4	14.20
Intertape® Stretch Flex® .8 Gauge	14"	1500" ft.	FH46603	7.8	15.70
Intertape® Stretch Flex® .7 Gauge	18"	1500" ft.	FH46604	8.6	17.65
3" Intertape® Stretch Flex®	3"	-	FH46605	3.4	17.80

STRAPPING CART

This **Universal Strapping Cart** is designed for use with both Poly and Steel strapping. Now you only need one cart for both types of strapping. Unique multi-tier discs allow for use with strapping core sizes of 16" x 3", 16" x 6" and 8" x 8". Cart includes storage tray for holding clips, seals and tools. Heavy-duty wheels for portability. Steel construction with powder coat finish. Accepts Steel & Poly.



OAL Size (in.)	Model	Shpg. Wt.	\$ Each
25" x 20 1/4" x 40 1/4"	FH46700	70.0	220.00
Steel Magnus Strapping			
1/2 x 0.020, 1525 lbs.	FH46701	105.0	160.00
5/8 x 0.020, 1900 lbs.	FH46702	105.0	160.00
3/4 x 0.020, 2250 lbs.	FH46703	105.0	160.00
Steel Snap-On Seals			
1/2	FH46704	1.3	6.90
5/8	FH46705	2.0	7.20
3/4	FH46706	1.9	9.90

Poly strapping and seals are available, call FHS for pricing.

STEEL STRAPPING TOOLS

These are the tools that you need to cut and seal strapping. Cutter cuts up to 5/8" wide strapping. Tensioner features ratchet action that applies maximum tension instantly, pulling and cutting 3/4" strapping with little effort.



Strapping Width (in.)	Model	Shpg. Wt.	\$ Each
Tensioner			
3/8 to 3/4	FH46710	5.0	79.00
Sealer			
3/8 to 1/2	FH46711	5.0	39.00
5/8 to 3/4	FH46712	5.0	41.00
Cutter			
3/8 to 1	FH46713	5.0	29.00

CARGO BARS

- ◆ Keep trailer contents in place -- eliminate damaged goods
 - ◆ Simple mechanical lock - will not vibrate loose
- When trucks move, keep trailer contents securely in place with these easy to use Cargo Bars. Constructed of 1-1/2" square tubing, unless specified, 14 gauge construction won't bend or give. 4" square articulating steel end plates feature rubber pads for positive gripping action. Fits between trailer walls.



Description	Service Range (in.)	Model	Shpg. Wt.	\$ Each
One Piece Aluminum Ratchet (Round Tube)	89 x 103	FH47000	16.0	60.50
One Piece Aluminum (E-Track)	85 x 96	FH47001	19.0	69.00
One Piece Aluminum (E-Track)	91 x 102	FH47002	22.0	72.00
One Piece Steel	87 x 119	FH47003	20.0	41.50
One Piece Steel Galvanized	87 x 119	FH47004	22.0	50.50
Two Piece Steel Folding Galvanized	88 x 116	FH47005	22.0	55.00
Two Piece Steel Telescopic Galvanized	80 x 139	FH47006	33.0	77.50
Two Piece Steel E Track End Pads	87 x 116	FH47007	22.0	59.50
10' section of E-Track for trailers	10' Long	FH47008	17.0	31.00

CARGO BAGS

Cargo Bags are an economical, lightweight and clever way to keep your truck contents from shifting and damaging the goods. When full the bags add padding with very little weight. Protects the doors from sliding and causing costly damage.



WITHOUT CARGO BAGS

WITH CARGO BAGS



Bag Size	Model	Shpg. Wt.	\$ Each
48" x 36"	FH47111	4.0	9.90
48" x 84"	FH47112	5.0	16.15

CARGO STRAPPING

- ◆ Guard against damages from slipping and shifting loads while moving products
 - ◆ Tough strapping fabric is made of a polyester webbing
- Tighten securely around cargo to help prevent damage and load shifting during transit. Spring loaded E-Track fittings provide quick one-handed connection to anchor point. Strap width 2 in.



Tightening Mechanism	Fastener	Working Length	Working Load (lbs.)	Model	Shpg. Wt.	\$ Each
Ratcheting	E-Clip	12'	1,000	FH47100	4.0	17.00
CAM	E-Clip	16'	1,200	FH47101	4.0	18.00
Ratcheting	E-Clip	16'	1,200	FH47102	4.0	19.00
Ratcheting	Rod Hook	27'	3,325	FH47103	10.0	26.00
Ratcheting	Flat Hook	27'	3,325	FH47104	10.0	26.00
D-Ring/Strap	E-Clip	6"	800	FH47105	1.0	

STRAP CLIPS AND EDGES

Description	Model	Shpg. Wt.	\$ Each
BEAM E-SOCKET supports the end of a 2 x 4	FH47106	2.0	4.50
TIE OFF the "D" ring when attached to the E-Track	FH47107	2.0	6.50
RUBBER EDGE GUARD 3 3/4" x 12" (Qty. 50)	FH47108	46.0	79.00
RUBBER EDGE GUARD 5" x 6" (Qty. 100)	FH47109	31.0	96.50
STEEL EDGE GUARDS 7 1/2" x 4" (Qty. 10)	FH47110	15.0	58.00

INDUSTRIAL BUNGEE CORDS

Deluxe, heavy-duty bungees provide similar strength to EPDM straps. Nylon-coated cords have hardened hooks with yellow dichromate finish. Work well in most tarp applications and with heavier loads. Black Cord.



Length (in.)	Model	Shpg. Wt.	\$ Each
13	FH47200	0.3	1.10
18	FH47201	0.3	1.35
24	FH47202	0.3	1.65
32	FH47203	0.4	1.90
36	FH47204	0.4	2.15
48	FH47205	0.4	2.45

DOOR PROTECTION AND PACKAGING SOLUTIONS

3" HINGE PROTECTOR

The Hinge Protector snaps over the hinge and is secured with one staple through the flap.

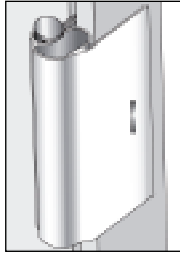

Desc.	Pkg. Qty.	Model	Each
Hinge Protector	1,000	FH80001	130.00

* Ask about discounts on larger quantities

UNIVERSAL CORNER SPACER/RETAINER

Provides protection for hinge and door face by creating a 1/4" spacing between doors during shipment and storage.

- Holds the door shut during shipping.
- Gives the corner joint additional support.



Staple to the sides of the jamb.

Desc.	Pkg. Qty.	Model	Box
Corner Spacer	500	FH80002	8.00

* Ask about discounts on larger quantities

RUBBER BAND HINGE PROTECTOR

Economical solution to hinge protection.

- One size fits all.
- Blue Color
- Rubber will not stain Wood, Metal or Paint



Desc.	Pkg. Qty.	Model	Box
Rubber Band	1,950	FH80003	70.00

SELF ADHESIVE MARGIN / TRIM SPACERS

Self adhesive spacers maintain perfect reveal between the door and jamb. Light weight adhesive allows for easy removal of spacers when the door is opened, either before or after installation. Can be left in place through the installation process.

- 3/32" T-Spacers for Exterior Doors
- 1/8" T Spacers for Interior Doors



Desc.	Pkg. Qty.	Model	Box
3/32" T-Spacer	5,000	FH80004	405.00
1/8" T-Spacer	5,000	FH80005	443.00

* Ask about discounts on larger quantities

BOTTOM STRAP

Secures jamb and door when no sill is attached. Recommend one staple on side of jamb and two into the door bottom.

- Helps maintain reveal around the door.
- Holds the door shut during shipping.
- Protects bottom corners and provided skid plate.
- Gives the corner joint additional support.

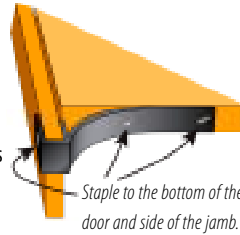

Staple to the bottom of the door and side of the jamb.

Desc.	Pkg. Qty.	Model	Box
Bottom Strap	1,000	FH80006	120.00

* Ask about discounts on larger quantities

BOTTOM SKID

Skids attach to bottom of both jambs eliminating splitting of jamb face and providing a smooth plastic surface to glide doors.



Desc.	Pkg. Qty.	Model	Box
Bottom Skid	500	FH80007	75.00

* Ask about discounts on larger quantities

DOOR LIFT HANDLE

Handles are designed to ease lifting of heavy exterior doors, double doors and doors with side lites. Help protect warehouse staff, customers and the integrity of your doors.



Desc.	Pkg. Qty.	Model	Box
Handle	200	FH80008	38.00

* Ask about discounts on larger quantities

SAVE-A DOOR TEMPORARY LATCH

Temporary Latch has an adjustable design that fits any back set length. Install in seconds with no tools required. Great for builders contractors and painters.



Desc.	Pkg. Qty.	Model	Each
Temp. Latch	1	FH80009	.80

FLAT JAMB CLOSURE CLIP

The one-piece, low profile Closure Clip is the easiest on the market to install and remove. Used on interior and exterior doors to secure the door to the jamb, reduce sag and maintain the door's reveal all the way through installation. Fits 5/8" and 11/16" jamb.

SPLIT JAMB CLOSURE CLIP

The Split Jamb Closure Clip is advantageous for those facilities that apply casing to the doors prior to shipping. This one-piece clip, fits flat and split jamb interior doors without interfering with the casing. Reduces sag and maintains the door's reveal through point of sale and installation.

2 3/4" BACKSET CLOSURE CLIP

The 2 3/4" Backset Closure Clip is an outstanding clip for exterior doors and like all of our clips has the unique one-piece design eliminating extra steps during installation.

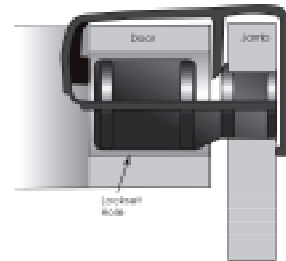

Description	Pkg. Qty.	Model	Box
Flat Jamb	1,000	FH80010	195.00
Split Jamb	1,000	FH80011	195.00
2 3/4" Backset	1,000	FH80012	215.00

* Ask about discounts on larger quantities

SHIPPING BOLT/DOOR LATCH

Insures your product's safe delivery. No unsightly nail holes through the jam into the door from shipping. Also doubles as a shipping bolt to prevent damage to jam or door. (Split jambs)



SHIPPING BOLT & SNAP NUT

No longer do you need to use unsightly nails for your doors during shipping. Re-useable shipping bolt protects door from swinging open and damaging the door with nail holes.



Desc.	Pkg. Qty.	Model	Each
Bolt/Latch	1	FH80013	.65

DOCK LOADING LIGHTS

Lights minimize freight damage while expediting loading and unloading operations. Provides uniform visibility inside trailers or around dock areas. All Dock Loading Lights are UL listed.

Incandescent Lights offer good color, low replacement cost and turn on instantly even in cold environments. It utilizes a 90 watt bulb, sold separately. Adjustable arm knuckle joint allows vertical and horizontal positioning.

Halogen Incandescent Lights typically provides more lumens/watt, better energy efficiency, has a longer service life and experiences less light depreciation over its lifetime. It is supplied with a 500 watt bulb. Light turns on instantly.



Description	Length (in.)	Model	Shpg. Wt.	\$ Each
Incandescent, Single Arm	24	FH47500	19.0	81.00
Incandescent, Double Arm	40	FH47501	22.0	91.00
Incandescent, Double Arm	60	FH47502	28.0	109.00
Incandescent, Triple Arm	90	FH47503	42.0	195.00
Halogen Incandescent, Double Arm	40	FH47504	20.0	127.00

INDUSTRIAL ACRYLIC CONVEX MIRRORS

These Acrylic Convex Mirrors eliminate those blind spots and danger areas found in most industrial settings. Comes standard with hanging hardware.



Description	OAL Size (in.)	Distance Covered (ft.)	Model	Shpg. Wt.	\$ Each
Round	12	12	FH47600	5.0	36.00
Round	18	20	FH47601	9.0	54.00
Round	26	26	FH47602	14.0	78.00
Round	30	30	FH47603	20.0	110.00
Rectangular	26"Wx16"H	24	FH47604	12.0	86.00

LAMINATED DOCK BUMPERS

Laminated style dock bumpers provide durable, economical protection for your loading dock and trailers. Units are constructed of fabric reinforced rubber from recycled truck tires. Installation is quick and easy by bolting or welding units to dock. Installation hardware sold separately. (Width is measured bolt hole center to bolt hole center.)



Type	Overall Size	Model	Shpg. Wt.	\$ Each
A	10"H x 12"W x 4.5"	FH48000	29.0	35.00
A	10"H x 14"W x 4.5"	FH48001	32.0	37.00
A	10"H x 18"W x 4.5"	FH48002	36.0	43.00
A	10"H x 24"W x 4.5"	FH48003	47.0	52.00
A	12"H x 36"W x 4.5"	FH48004	85.0	81.00
A	6"H x 36"W x 4.5"	FH48005	45.0	54.00
B	20"H x 11"W x 4.5"	FH48006	48.0	50.00

DOUBLE SUCTION CUP

Lever operated Double Suction Cup provides tremendous holding power on any smooth, flat surface. Ideal for safely handling glass panels, sheet steel and smooth laminates.



Desc.	Model	Shpg. Wt.	\$ Each
Double Suction Cup	FH48500	2.0	10.75

PALLET BUSTER

Get rid of broken or unsightly pallets quickly and safely. Lightweight and easy to use. Unique dual prying action with nail puller. Also can be utilized for dockboard removal.



Length	Model	Shpg. Wt.	\$ Each
41.5"	FH40410	8.0	49.00

INSTALLATION HARDWARE

Installing bumpers is no longer a chore with concrete anchor bolts. Use 4" long anchors with Laminated Bumpers and 6" long anchors for Molded Bumpers. Sold Individually.



Concrete Anchor Bolts Size & Anchor it Accommodates	Model	Shpg. Wt.	\$ Each
Laminated Bumpers, 3/4" x 4"	FH48050	1.0	2.75
Masonry Bit 3/4 Dia.	FH48052	1.0	12.90

3 HP DUST COLLECTOR

When you are ready to take your dust collection system to the next level, this 3 HP Dust Collector will be your first choice. The increased air suction capacity will allow you to build bigger and more complex dust collection systems with room to spare.

Specifications

Motor size:	3 HP, 220V, Single-phase, 3,450 RPM
Motor Amp draw:	220V - 18A
Impeller:	13" balanced steel radial fin
Maximum inlet size:	8"
Inlet adapter:	4-way x 4" inlets
Air suction cap.:	Approx. 2,800 CFM
Static pressure:	14.4
Bag size (Dia. x depth):	19" x 33" (4)
Height (with bags inflated):	78"
Bag volume:	10.8 Cubic Feet
Standard bag filtration:	30 Micron



Desc.	Model	Shpg. Wt.	\$ Each
3 HP Dust Collector	FH50010	170.0	675.00
Replacement Upper Bag	FH50011	2.0	28.95
Replacement Lower Bag	FH50012	2.0	28.95
2.5 Micron Oversized Bag, 18" x 40"	FH50013	1.0	62.90

3/4HP DUST COLLECTOR

Perfect for lathes, drill presses, mortising machines, and sanders that don't have an easy means of collecting dust.

Specifications

Motor:	¾ HP, 110V, Single-phase
Motor Amp draw:	9
Air suction capacity:	650 CFM
Static pressure:	3.4"
Bag capacity:	2.8 cubic feet
Number of 4" intake holes:	1
Impeller:	9" balanced steel, radial fin
Portable base size:	12" x 14"
Bag size (dia. x depth):	16" x 24"
Height with bags inflated:	19-1/2"

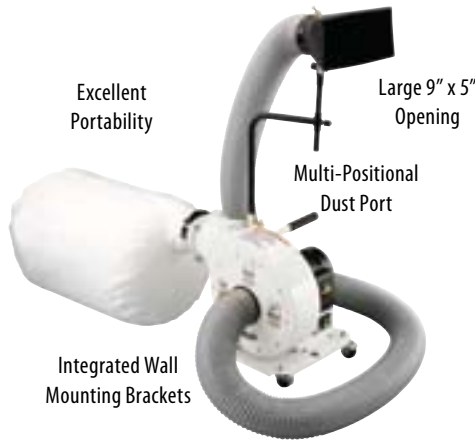

Desc.	Model	Shpg. Wt.	\$ Each
¾ HP Dust Collector	FH50014	51.0	210.00
Replacement Bag	FH50015	1.0	23.00

BENCH TOP DOWNDRAFT TABLES

These Bench Top Downdraft Sanding Tables provide a simple and economical solution to capturing the dust created by portable hand sanders. Low profiles allow these sanding tables to sit on top of the workbench during sanding operations and then store out of the way when not needed. Internal baffles & slotted table surface maximize air movement and dust control. Non skid top and feet.



Dust Port	OAL Size (in.)	Model	Shpg. Wt.	\$ Each
2½"	15 x 25 x 5	FH50100	8.0	150.00
4"	20 x 40 x 6¼	FH50101	24.0	189.00



DUST COLLECTION ACCESSORIES

DUST COLLECTION SEPARATORS

Our Dust Collection Separator increases the efficiency and capacity of standard dust collection systems. Designed to fit securely on top of a standard 30-gallon metal trash can (large) or 5-gallon bucket (small), this molded ABS fitting is engineered to use cyclonic action to drop out larger particles from the dust flow. The fitting features molded inlets and outlets which can be easily connected to standard systems using 4" flexible hose. You'll be amazed at how well it works!



Size	Model	Shpg. Wt.	\$ Each
Large (fits 30-gallon)	FH51050	2.0	31.50
Small (fits 5-gallon)	FH51051	1.0	23.95

BLAST GATES

Used in every dust collection system to control air flow from one machine to another, blast gates maximize system efficiency. Plastic blast gates are economically priced, have a textured surface and an easy sliding gate action.



Outside Dia. (in.)	Model	Shpg. Wt.	\$ Each
3	FH51200	0.5	5.00
4	FH51201	0.5	6.00
5	FH51202	0.5	7.25

UNIVERSAL DUST HOOD

The Universal Dust Hood fits over a 4-1/2" dust port and can be adapted to fit many woodworking tools. Use it on table saws, bandsaws, shapers, sanders etc. by simply attaching it directly to the machine, or by using a custom-built cabinet.

- ♦ Material thickness is 3/32"
- ♦ Outlet diameter is 4" overall
- ♦ Flange is 3/4" wide
- ♦ Overall size is 6-1/4" wide x 6-1/4" high x 2-1/2" deep



Desc.	Model	Shpg. Wt.	\$ Each
Universal Dust Hood	FH51203	0.2	5.00

DUST COLLECTION ACCESSORIES

T-FITTINGS

T-fittings provide the option of adding branches to a system to service each machine in a shop. T's are very helpful when space or design constraints prohibit the use of Y's.



Outer Dia.	OAL Size (in.)	Model	Shpg. Wt.	\$ Each
3"	7 ⁵ / ₈ x 2 ⁷ / ₈ x 6	FH51210	.52	4.25
4"	9 ³ / ₄ x 4 ¹ / ₁₆ x 8	FH51211	1.05	7.25

Y-FITTINGS

Y's are used to attach branch lines to service more than one machine. This design provides increased lateral air flow and efficiency over other types of fittings.



Outer Dia.	OAL Size (in.)	Model	Shpg. Wt.	\$ Each
3"	7 ⁷ / ₈ x 2 ⁷ / ₈ x 6 ³ / ₄	FH51215	.6	5.25
4"	9 ¹³ / ₁₆ x 4 ¹ / ₁₆ x 8 ¹ / ₄	FH51216	.93	7.25

ELBOWS

Elbows are necessary whenever ductwork changes direction, such as from a dust collector to an overhead main line, or when connecting individual machines to branch lines.



Outer Dia.	Centerline Radius	Model	Shpg. Wt.	\$ Each
3"	3"	FH51220	.55	4.25
4"	4"	FH51221	.83	7.25

SPLICES

Splices round out our full line of special fittings for dust collection systems. Used to connect full sections of hose for longer runs or to utilize short sections.



Outer Dia.	OAL Size (in.)	Model	Shpg. Wt.	\$ Each
3"	5 x 3 x 3	FH51225	.28	3.75
4"	5 x 4 x 4	FH51226	.46	4.00

REDUCERS

We engineered the inside diameter of the 2-1/2" side of each of these fittings to duplicate the 2-1/2" opening on your shopvac®. Insert the shopvac® brand hose to the vac and the other end to one of these fittings to power the dust collection system. The outside diameter matches our standard dust collection hose to function as regular reducers.



Outer Dia.	OAL Size (in.)	Model	Shpg. Wt.	\$ Each
3" x 2"	4 x 3 x 3	FH51230	.15	3.50
4" x 3"	2 ⁷ / ₁₆ x 4 x 4	FH51231	.21	3.50
5" x 4"	3 ³ / ₈ x 5 x 5	FH51232	.15	4.25

UNIVERSAL REDUCER

Seven-step adapter provides a multitude of dust collection reducing options. Simply cut away unneeded steps with a hacksaw. Outside diameter step sizes include 1", 2", 2-1/2", 3", 4", 5" and 6". Wall thickness is 1/8".



OAL Size	Model	Shpg. Wt.	\$ Each
9 ¹ / ₂ x 6 x 6	FH51233	.6	7.25

COMBINATION ADAPTERS

These fittings provide a step down from a larger main line to smaller branch lines. This step-down increases air velocity near the machine where it's needed most. These three size reductions will handle most system needs.



Outer Dia.	OAL Size (in.)	Model	Shpg. Wt.	\$ Each
2 ¹ / ₂ " x 3"	3 ³ / ₁₆ x 3 x 3	FH51240	.15	5.00
2 ¹ / ₂ " x 4"	4 ¹ / ₂ x 4 ¹ / ₄ x 4 ¹ / ₄	FH51241	.21	5.00

HOSE HANGERS

Support flexible hose anywhere with these Hose Hangers. Fasteners not included.



Size	Model	Shpg. Wt.	\$ Each
2 ⁵ / ₁₆ "	FH51250	0.1	.95
2 ³ / ₄ "	FH51251	0.1	.95
3 ¹ / ₄ "	FH51252	0.1	.95
4 ¹ / ₄ "	FH51253	0.1	.95
5 ¹ / ₄ "	FH51254	0.1	.95

BLACK DUST COLLECTION HOSE

Our hoses are ideally suited for dustremoval because of their strength, durability and flexibility. Available in the most requested sizes and priced to move!



Hose Size (Dia. x Length)	Model	Shpg. Wt.	\$ Each
2" x 10'	FH51270	2.5	10.25
2 ¹ / ₂ " x 10'	FH51271	2.8	13.25
3" x 10'	FH51272	3.9	15.00
3" x 20'	FH51273	4.7	27.00
3" x 50'	FH51274	11.8	64.00
4" x 10'	FH51275	4.9	17.50
4" x 20'	FH51276	9.4	34.50

HOSE CLAMPS

Hose clamps are used to connect flexible piping to dust hoods, blast gates and fittings. Choose from two styles, steel band or wire from 2" to 9" in diameter.



Size Dia. (in.)	Steel Model	\$ Each	Wire Model	\$ Each
2	FH51300	.95	FH41320	.95
2 ¹ / ₂	FH51301	.95	FH41321	.95
3	FH51302	.95	FH41322	.95
4	FH51303	1.15	FH41323	.95
5	FH51304	1.15	FH41324	.95
6	FH51305	1.15	FH41325	.95
7	FH51306	1.95	FH41326	.95
8	FH51307	1.95	FH41327	1.20
9	FH51308	1.95	FH41328	1.40

24" FLOOR SWEEP

This is one of the handiest items to have in the shop! Use it in conjunction with our 4" blast gate (FH51201) to clean up floor messes. Sweep dust in, and it's gone!



Outer Dia.	OAL Size (in.)	Model	Shpg. Wt.	\$ Each
4"	24 W x 3.5 H x 7 D	FH51209	.73	10.25

MOBILE AIR CIRCULATORS

LIGHT COMMERCIAL DIRECT-DRIVE

Fan head tilts 360 Degree for cooling in any direction. Wheeled cart with handle provides easy mobility. Shaded pole, open air-over motors have automatic thermal protection. 9-ft., 3-cond. cord. UL Listed.

- ♦ Black powder-coated steel 3-blade propellers
- ♦ Chrome-plated wire guards comply with OSHA Standard 1910.212, 1/2" max. opening



INDUSTRIAL DIRECT-DRIVE AND BELT-DRIVE

Heavy-duty fans move high volumes of air at low RPM. Include tilting kit that allows for directional airflow. 7" diameter wheels provide mobility. 10-ft., 3-cond. cord has grounded molded plug. Shipped fully assembled. UL Listed and CSA Certified.

Direct-drive fans feature permanent split capacitor motors with automatic thermal protection, 3-blade propellers, and low maintenance. Belt-drive fans have capacitor-start motors with automatic thermal protection, 5-blade propellers, and low noise level of operation.

- ♦ Charcoal gray powder-coated steel housing and guard
- ♦ Steel propellers
- ♦ Gray polyester powder-coated wire guards comply with OSHA Standard 1910.212, 1/2" max. opening

Propeller Dia. (in.)	CFM High	CFM Med	CFM Low	Air Velocity (FPM) @ 20 Ft.			RPM	Model	Shpg. Wt.	\$ Each
				HP						
Light Commercial Direct-Drive										
24	4950	4552	4190	—	1/4	1500/1300/1100	FH55000	26.0	239.00	
30	6230	5086	5086	—	1/4	1100/900/700	FH55001	49.0	269.00	
Industrial Direct-Drive										
24	5800	—	3600	350/245	1/3	825/600	FH55002	66.0	339.00	
30	6890	—	4687	400/280	1/3	825/600	FH55003	80.0	449.00	
36	12241	—	8327	780/545	1/2	825/600	FH55004	101.0	569.00	
42	15000	—	9000	975/685	1/2	825/600	FH55005	114.0	719.00	
Industrial Belt-Drive										
36	14100	—	9000	417/292	1/2	1725/1140	FH55006	168.0	779.00	
42	18000	—	10,000	470/295	1/2	1725/1140	FH55007	200.0	879.00	
48	21200	—	13,900	500/300	3/4	1725/1140	FH55008	227.0	979.00	

EVAPORATIVE COOLING FANS

Designed for use when air conditioning is cost-prohibitive, impractical, or unavailable. Effectively cool equipment such as generators and compressors. Operate by connecting to 115V power supply and water. Water can be supplied by garden-type water hose. Fans feature one-piece polyethylene plastic housing and high-tech polymer venturi with quieter-running, noncorrosive fan blades. High-efficiency rigid evaporative media. 36 and 48" fans roll on heavy-duty ball bearing casters. 16" models are offered in heavy duty versions with 1/2 HP motors. UL Listed. FH55103 includes a 22-gallon reservoir and roll-about cart with casters.



FH55100



FH55101



FH55102



FH55103

Propeller Dia. (in.)	Drive Type	No. of Speeds	Air Delivery (CFM)	Water Capacity (Gal)	Volts	Operating Amps	HxWxD	Model	Shpg. Wt.	\$ Each
16	Direct	3	1540/1930/2230	3	115	3.8	30.5 x 37.5 x 22	FH55100	74.0	789.00
16	Direct	3	2500/3280/3900	22	115	5.1	59 x 37.5 x 22	FH55101	145.0	1099.00
36	Direct	Adj.	10,100	20	115	11.3	67 x 62 x 32	FH55102	240.0	2679.00
48	Belt	2	11,000/20,000	25	115	12.0	86 x 74 x 36	FH55103	405.0	3489.00

Replacement Media Küül® Pads

Fits 16" Units	24 x 12 x 6	FH55104	2.4	41.95
Fits 36" Units	48 x 12 x 6	FH55105	4.6	51.55

Accessories

16" Air Duct Adapter	14 x 21 x 21	FH55106	7.0	103.55
Vinyl Cover for 16" Units	12 x 10 x 1½	FH55107	3.0	36.40
Heavy-Duty All Terrain 6" Caster Kit for 24 and 36" Units	—	FH55108	35.0	160.75
Vinyl Cover for 24 and 36" Units	18 x 13 x 2½	FH55109	6.0	42.95
50-Gallon Port-A-Filter Water Tank	41 x 20 x 36	FH55110	72.0	423.25
Mineral Knockout Strips	—	FH55111	.33	70.20

COMMERCIAL UNASSEMBLED PEDESTAL- AND WALL/CEILING-MOUNTED AIR CIRCULATORS

Suitable for air circulation and cooling in clean, dry environments. Low sound levels for commercial applications. 2-speed open air-over motors with ball bearings provide long life. UL Listed.

- ♦ Factory wired 10-ft. 3-cond. cord with grounded plug
- ♦ Black polyester powder-coated wire guards comply with OSHA Standard 1910.212, 1/2" max. opening
- ♦ 2 Speed, 115 Volts



Propeller Dia. (in.)	CFM High	CFM Low	Air Velocity (FPM) @ 20 Ft.	HP	RPM	Model	Shpg. Wt.	\$ Each
Pedestal Mounted								
20	3714	2626	400/360	1/8	1100/700	FH55200	75.0	195.00
24	5465	3805	590/300	1/4	1100/800	FH55201	75.0	225.00
30	7261	4674	715/480	1/4	1100/775	FH55202	83.0	250.00
Wall/Ceiling Mounted								
20	3714	2626	400/360	1/8	1100/700	FH55250	32.2	180.00
24	5465	3805	590/300	1/4	1100/800	FH55251	36.0	200.00
30	7261	4674	715/480	1/4	1100/775	FH55252	46.0	220.00

LIGHT COMMERCIAL FLOOR/WALL/CEILING AIR CIRCULATORS

Three-way mounting capability allows for versatile installation. Can be positioned near a window to maximize ventilation. Shaded pole, open air-over motors have automatic thermal protection. Black powder-coated steel propellers. 9-ft., 3-cond. cord. UL Listed.

- ♦ Includes multipurpose wall and ceiling bracket and cord wrap
- ♦ Chrome-plated wire guards comply with OSHA Standard 1910.212, 1/2" max. opening



Propeller Dia. (in.)	CFM High	CFM Med	CFM Low	RPM	HP	H x W x D	Model	Shpg. Wt.	\$ Each
12	1057	804	591	1500/1300/1100	1/10	16 x 16 x 9.5	FH55270	10.0	81.00
16	2467	2127	1810	1500/1300/1100	1/6	19 x 22 x 9.5	FH55271	14.7	99.00
20	3668	3153	2697	1500/1300/1100	1/6	24 x 24 x 12	FH55272	16.6	117.00

PORTABLE VACS

1-GALLON WET/DRY

Lightweight, compact vac includes 6-ft. x 1 1/4" hose, round brush, utility nozzle, crevice tool, wall bracket/tool holder, 18-ft. power cord, foam sleeve, and dry disc filter.



FH55273

Size (Gal.)	Peak HP	Amps @ 120V	Static Pressure	CFM	Model	Shpg. Wt.	\$ Each
1	1.5	5.75	54	120	FH55273	8.4	50.00
5	5.5	11.5	59	195	FH55274	21.2	110.00

5-GALLON, HEAVY-DUTY WET/DRY

Compact vac comes with a powerful single-stage bypass motor. The rustproof, dent-resistant poly tank has on-board accessory and cord storage, as well as a wall-mounting bracket for easy storage. Includes: 7-ft. x 1 1/2" Lock-On® hose, crevice tool, claw-style utility nozzle, heavy-duty cartridge filter, and high-efficiency collection bag filter. 20-ft. power cord.



FH55274

COMMERCIAL BROOMS & DUST PANS



Desc.	Model	Shpg. Wt.	\$ Each
24" Broom	FH56000	3.7	29.50
Bench Brush	FH56001	0.6	6.50
12" Metal Dustpan	FH56002	1.2	6.50
Dust Scoop	FH56003	3.8	29.00

ANTIFATIGUE DRY-AREA MATTING

Exclusive **Dyna-Shield** enhanced top surface resists abrasions, extending mat's service life. Dense, closed-cell vinyl sponge construction offers exceptional worker comfort, helping to relieve back and leg discomfort. Beveled edges on all 4 sides of mat minimize tripping. Mats are available with yellow borders that comply with OSHA Code 1910-144. 1/2" Thick



FH56106

Size (ft.)	Model	Shpg. Wt.	\$ Each
2 x 3 Black	FH56100	5.2	26.95
3 x 5 Black	FH56101	13.0	66.95
3 x 12 Black	FH56102	30.0	160.95
3 x 60 Black	FH56103	165.0	805.95
2 x 3 Black/Yellow	FH56104	6.0	29.95
3 x 5 Black/Yellow	FH56105	13.0	74.95
3 x 12 Black/Yellow	FH56106	29.0	179.95
3 x 60 Black/Yellow	FH56107	151.0	899.95

BRUSH SETS

12 PC. NYLON BRUSH SET

Clean deep crevices and hard to reach corners with these nylon brushes. The nylon bristles are soft enough so they won't scratch most surfaces, but stiff enough to effectively knock loose grit and grime. Package of 12 provides plenty of replacements to use with a variety of solvents and cleaners.



Desc.	Model	Shpg. Wt.	\$ Each
12 Pc. Nylon Brush Set	FH56200	0.5	5.95

50 PC. GLUE BRUSH SET

Small enough to fit into tight mortises, yet large enough to spread glue quickly, these glue brushes belong in every woodshop. Plumbers and pipe fitters also use these brushes for flux and pipe dope. Poly-bagged.



Desc.	Model	Shpg. Wt.	\$ Each
50 Pc. Glue Brush Set	FH56203	1.0	10.95

150 PC. MEGA BRUSH SET

For not much more than the cost of a few off-the-shelf foam or bristle brushes, this Mega Brush Set includes 50 Foam Brushes with Wooden Handles, 50 Bristle Brushes with Wooden Handles and 50 Glue Brushes in assorted sizes. Ideal for quick painting, staining and finishing jobs, as well as spreading glue, flux and pipe dope, the convenience factor alone makes this set one of the best deals around!



12 PC. BRASS BRUSH SET

These brushes clean crevices and corners that the softer nylon won't touch. Wire bristles are so aggressive they're ideal for cleaning steel parts and machinery. Package of 12 means there is a brush for every need!



Desc.	Model	Shpg. Wt.	\$ Each
12 Pc. Brass Brush Set	FH56201	1.0	7.20

50 PC. BRISTLE BRUSH SET

This 50-Piece Brush Set ensures always having a brush on hand for touch-up and craft work. Sizes include 5 - 1/2", 20 - 1", 15 - 2" and 10 - 3". All have wood handles.



Desc.	Model	Shpg. Wt.	\$ Each
50 Pc. Bristle Brush Set	FH56204	2.9	19.30

24 PC. FOAM BRUSH SET

This brush set includes 10 - 1" brushes, 8 - 2" brushes and 6 - 3" brushes. Poly-bagged with an eye-catching hang tag.



Desc.	Model	Shpg. Wt.	\$ Each
24 Pc. Foam Brush Set	FH56202	0.5	6.95

50 PC. FOAM BRUSH SET

This brush set includes 20 - 1" brushes, 20 - 2" brushes and 10 - 3" brushes. Conveniently boxed.



Desc.	Model	Shpg. Wt.	\$ Each
50 Pc. Foam Brush Set	FH56205	1.3	12.95

50 PC. 3/4" FOAM BRUSH SET W/WOODEN HANDLE

Great for detailing and small touch-up work, these 3/4" wide Foam Brushes do an excellent job.



Desc.	Model	Shpg. Wt.	\$ Each
150 Pc. Mega Brush Set	FH56206	4.1	33.50

Desc.	Model	Shpg. Wt.	\$ Each
50 Pc. 3/4" Foam Brush Set	FH56207	.75	7.95

ADHESIVES, SEALANTS & FILLERS



DAP BUTYL-FLEX GUTTER AND FLASHING SEALANT

VOC-compliant formula is durable, flexible, and ideal for sealing metal joints. Watertight bond remains flexible and resists cracking, crumbling, and weathering. White color.

Size	Brand	Model	Shpg. Wt.	\$ Each
10 oz.	DAP	FH56500	1.1	4.35



DAP DYNAFLEX® 230 PREMIUM LATEX SEALANT

Provides 50% total joint movement flexibility and a watertight, weatherproof seal. Ideal for crown molding, windows, doors, and siding. Cured caulk is mildew-resistant. Use on interiors or exteriors. Water cleanup. Meets Federal Spec. TT-5-00230c, Type II, Class A, and ASTM SPEC. C-920, Class 25. 50-year durability guarantee.

Color	Size (Oz.)	Model	Shpg. Wt.	\$ Each
White	10.1	FH56501	1.1	4.95
Clear	10.1	FH56502	0.8	4.95
Alum. Gray	10.1	FH56503	1.1	4.95



MAX 1000 ACRYLIC WINDOW AND DOOR SEALANT

Paintable and cleans with water. 35-year durability guarantee. Meets ASTM C-834.

Color	Size (Oz.)	Model	Shpg. Wt.	\$ Each
White	10.1	FH56504	1.1	3.15



WINDOW/DOOR 100% SILICONE RUBBER SEALANT

Provides watertight, weatherproof seal with minimum shrinkage. Remains flexible with outstanding performance in most applications.

Color	Size (Oz.)	Model	Shpg. Wt.	\$ Each
Clear	10.1	FH56505	0.8	6.15
White	10.1	FH56506	0.6	5.35



DAP TITANIUM® WINDOW AND DOOR SILICONE SEALANT

Adheres well to PVC, plastics, painted woods, Formica, and other difficult materials. 100% silicone-titanium enriched. Cold-weather application. Indoor/outdoor use. Meets ASTM C920, Class 25.

Color	Size (Oz.)	Model	Shpg. Wt.	\$ Each
White	10.1	FH56507	0.8	6.80



DAP TITANIUM SILICONE SEALANT

Actual titanium increases flexibility and provides greater adhesion to difficult surfaces like PVC and painted wood. Caulks and seals doors, windows, and corner joints. Non-paintable.

Color	Size (Oz.)	Model	Shpg. Wt.	\$ Each
Clear	10.1	FH56508	0.8	6.95



DAPTEX PLUS INSULATING FOAM SEALANT

High performance sealant has superior weather resistance. Conforms with AAMA and ASTM Standards. Will not over expand, it's paintable and trowelable and cleans up with water. Interior/Exterior use.

Color	Size (Oz.)	Model	Shpg. Wt.	\$ Each
White	12	FH56509	1.1	6.85

DAP PLASTIC WOOD® LATEX WOOD FILLER (RTU)

High quality wood filler that hardens to give a surface and body that looks like real wood. **For use on** furniture, doors, paneling, molding and other wood surfaces. Can be sanded, stained, cut, drilled, planed, varnished or painted. Interior/exterior use. Water cleanup.



Color	Size	Model	Shpg. Wt.	\$ Each
Natural	3.3 oz	FH56550	0.4	.90
White	3.3 oz	FH56551	0.4	.65
Golden Oak	3.3 oz	FH56552	0.4	.65
Red Oak	3.3 oz	FH56553	0.4	.65
Walnut	3.3 oz	FH56554	0.4	.65

DAP PLASTIC WOOD® LATEX WOOD FILLER (RTU)

High quality wood filler that hardens to give a surface and body that looks like real wood. **For use on** furniture, doors, paneling, molding and other wood surfaces. Can be sanded, stained, cut, drilled, planed, varnished or painted. Interior/exterior use. Water cleanup.



Size	Brand	Model	Shpg. Wt.	\$ Each
Pint	DAP	FH56555	1.6	6.00

DAP FAST N' FINA® INTERIOR/EXTERIOR LIGHTWEIGHT SPACKLING

One-step formula requires no sanding. Use with stucco, concrete, brick, wood, plaster, and drywall surfaces. Fast drying; no shrinkage. White color.



Size	Brand	Model	Shpg. Wt.	\$ Each
Quart	DAP	FH56600	1.0	6.20

WELDWOOD® ORIGINAL CONTACT CEMENT

Fast, high-strength bonding to a variety of surfaces. For use with all laminate products. Adheres to wood, masonry, and most metals with no clamping required. High heat and water resistance when dry.



Size	Brand	Model	Shpg. Wt.	\$ Each
Quart	DAP	FH56601	2.1	8.00
Gallon	DAP	FH56602	7.7	24.40

TITEBOND® INTERIOR WOOD GLUE

Fast Set Up, Heat Resistant, No Solvent Vapors, Cleans Up With Water. For Interior Woods. White color. Tensile Strength 3,550 PSI.

TITEBOND II® EXTERIOR WOOD GLUE

Water Resistant Formula That Cleans Up With Water, Unaffected by Finishes, Can Be Sanded. For Exterior Woods, Ideal For Radio Frequency (R-F) and Hot Press Gluing Systems. Tensile Strength 3,750 PSI.

TITEBOND III® WATER-RESISTANT WOOD GLUE

Water Resistant Formula That Cleans Up With Water, Unaffected by Finishes. For Interior and Exterior Woods. Tan Color. Tensile Strength 4,000 PSI.



Desc.	Size	Model	Shpg. Wt.	\$ Each
Interior	Gal	FH56651	9.0	20.85
Exterior	16 oz.	FH56652	1.2	6.85
Exterior	Gal	FH56653	9.2	25.55
Water-Resistant	8 oz.	FH56654	0.7	5.98
Water-Resistant	16 oz.	FH56655	1.2	9.15
Water-Resistant	Gal	FH56656	9.4	42.50

CAULK GUNS

HEX RODS

Have E-Z Thrust mechanism for smooth action and reduced effort. Include puncture tool.

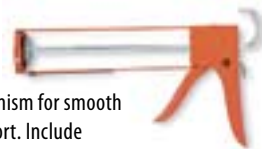

REVOLVING BARREL

Durable Welded All Steel



Description	Model	Shpg. Wt.	\$ Each
Hex Rod	FH56700	1.4	6.75
Revolving Barrel	FH56701	1.9	25.50

HYSO® E-00CL™

Fast Setting, Flowable, Low Odor, Clear Color

These two-part, room-curing adhesives are conveniently and accurately dispensed through hand-held meter-mix dispensing systems. The result is minimal waste. 50-ml dual cartridges.

Substrates: Metals, Thermoplastics, Thermoset Plastics, Glass, Ceramic, Masonry, Paper/Hardboard



Container Type	Shear Strength (PSI)	Model	Shpg. Wt.	\$ Each
Cartridge	2000-4000	FH56750	0.2	12.55

50-ML MANUAL DISPENSING GUN

Designed for use with all Hysol® 50-ml double barrel cartridges. Comes with two different plungers, allowing it to be used with either 1:1 or 2:1 ratio cartridges.



Description	Model	Shpg. Wt.	\$ Each
Cartridge Dispensing Gun	FH56751	0.6	66.50
Disposable Nozzle 10-pk.	FH56752	0.1	16.95

POLYURETHANE HOT MELTS

The adhesives set quickly and reduce the need for clamping or bracing in many uses. They can be used for indoor and outdoor projects.

- ◆ Waterproof, solvent-free, and nonflammable
- ◆ Create strong, permanent bonds
- ◆ Full cure in 24 hours
- ◆ Translucent



HIPURFORMER™ APPLICATOR

Includes: applicator, charger base, detachable power cord, carry case, and manual. Operating Temp 212° to 284°F

Description	Model	Shpg. Wt.	\$ Each
Applicator	FH56800	2.0	101.95

HIPURFORMER™ ADHESIVES

FH56801 and **FH56802** are designed for wood and wood-composite substrates. **FH56803** makes strong, permanent bonds on melamine, fiberglass reinforced plastic (FRP), ceramics, metal, and most common substrates. Temp. Range -20° to 275°F, Size 50 g

Appl. Time (Sec.)	Shear Strength (Psi)	Model	Shpg. Wt.	\$ Each
30	1360	FH56801	0.2	10.15
60	1480	FH56802	0.2	10.15
75	900	FH56803	0.2	10.15

PREMIUM VINYL ELECTRICAL TAPE

Super 33+

Premium-grade with an aggressive adhesive that provides fast, sure grab. Flexible vinyl backing conforms to irregular surfaces. Flame retardant. Resists weather, abrasion, alkalis, acids and corrosion.

- ◆ 7 mils. thick, Max temp. 220°, Max Volts 600, 3/4" Width



Desc.	Length (Ft)	Model	Shpg. Wt.	\$ Each
Super 33	66	FH57000	0.2	4.75
Super 33, 10 pk.	20	FH57001	0.7	21.15

DUCT AND INDUSTRIAL CLOTH TAPE

UTILITY-GRADE DUCT TAPE

For noncritical, temporary repair applications and general use. Meets requirements of UL 723. 60 ft./per. roll



DUCT TAPE 3939

Heavy-duty performance in holding, splicing, patching, sealing, and seaming applications. Strong and conformable, with high tack and easy tear action. For applications ranging from containment sealing to masking, where medium tensile strength on many surfaces is needed. 60 ft./per. roll



PREMIUM-GRADE DUCT TAPE

High-strength tape seals and seams joints and overlaps in air handling systems for durable closures. Provides consistent, trouble-free performance. Extremely high-tack adhesive with performance over a wide temperature range. Meets requirements of UL 723. For use by professional contractors in all maintenance, repairing, protecting, and holding applications. 60 ft./per. roll



DOUBLE-FACED CLOTH TAPE

Has liner for carpet hold-down, hanging polyethylene sheets during construction, and general mounting and holding. 36 ft./per. roll



Desc.	Model	Shpg. Wt.	\$ Each
Utility Grade Duct Tape	FH57020	1.4	5.85
Duct Tape 3939	FH57021	1.6	8.10
Premium Grade Duct Tape	FH57022	2.1	18.45
Double-Faced Cloth Tape	FH57040		22.45

MASKING TAPES

SCOTCH® PERFORMANCE 233+

Quickly conform to curves and contours. Excellent performance when applying to multistage or urethane coatings. Remove cleanly from all surfaces, including rubber moldings and weatherstripping, within three days of application. Color: Green



Width (in.)	Model	Shpg. Wt.	\$ Each
1/2	FH57050	0.2	3.15
3/4	FH57051	0.3	4.00
1	FH57052	0.5	5.30
1 1/2	FH57053	0.7	7.95
2	FH57054	0.9	10.60
3	FH57055	1.3	15.95

SCOTCH® GENERAL PURPOSE 234

Crepe paper tapes provide reliable masking and clean removal with excellent control unwind. Withstand up to 30 minutes at 250°F. Color: Natural



Width (in.)	Model	Shpg. Wt.	\$ Each
1/2	FH57070	0.2	3.25
3/4	FH57071	0.3	4.55
1	FH57072	0.5	5.40
1 1/2	FH57073	0.7	8.20
2	FH57074	0.9	10.95
3	FH57075	1.3	16.30

SCOTCH-BLUE™ MULTISURFACE PAINTER'S TAPE 2090

Removes cleanly from interior or exterior surfaces without adhesive transfer or surface damage for up to 14 days, even in direct sunlight.

Medium-adhesion tape is ideal for painted walls and trim, woodwork, glass, and metal. Color: Blue



Width	Model	Shpg. Wt.	\$ Each
3/4	FH57091	0.3	4.25
1	FH57092	0.5	5.85
2	FH57090	0.7	11.35

GLOVES

ECONOMY LEATHER PALM GLOVES

Features leather wrapped index finger, fingertips, knuckle strap, and pull with striped canvas back and wing thumb.



Description	Size	Brand	Model	Shpg. Wt.	\$ Each
Safety Cuff	Small	Condor	FH60001	0.3	1.50
Safety Cuff	Large	Condor	FH60002	0.3	1.50
Safety Cuff	X-Large	Condor	FH60003	0.3	1.50

POWDER-FREE DISPOSABLE NITRILE GLOVES

Powder-free, economy-grade.

Rollled cuff design. Lightly pebbled texture improves grip and handling.



Size	Thickness (mil)	Length (in.)	Gloves Per Pkg.	Model	Shpg. Wt.	\$ Each
S	4	9 1/2	100	FH60020	1.8	8.85
M	4	9 1/2	100	FH60021	1.9	8.85
L	4	9 1/2	100	FH60022	2.0	8.85
XL	4	9 1/2	100	FH60023	2.1	8.85
XXL	4	9 1/2	100	FH60024	2.1	8.85

ERGODYNE® WRIST WRAPS

Durable Ergodyne® woven elastic relieves repetitive movement-related wrist stress and strain. Adjustable hook-and-loop closure. Thumb Loop offers improved security, support, and comfort. Black color.



Description	Size	Wrist (in.)	Model	Shpg. Wt.	\$ Each
Standard Wrap	Universal	—	FH60040	0.1	2.65
Thumb Loop	S/M	5-7	FH60041	0.1	3.20
Thumb Loop	L/XL	7-9	FH60042	0.1	3.20

PUSH STICK AND BLOCKS

This essential safety items keep hands at a safe distance from blades and cutters while still maintaining control of the work piece against machine fences. Durable handles are designed for maximum control. A true necessity when running narrow stock.

Desc.	Model	Shpg. Wt.	\$ Each
Push Block (MED)	FH60095		5.00
Push Block (Lg)	FH60096		8.00
Push Stick	FH60097		9.00



CUT- AND ABRASION-RESISTANT GLOVES

Tuff-Coat II™ w/Latex Palm

100% Kevlar® provides cut and puncture resistance. Textured natural rubber palm provides safe, sure grip and abrasion resistance. Coated fingertips and thumb crotch minimize wear to critical areas. An open back offers superior ventilation. Fully launderable.



Size	Brand	Model	Shpg. Wt.	\$ Each
S	Perfect Fit	FH60050	0.2	11.20
M	Perfect Fit	FH60051	0.2	11.20
L	Perfect Fit	FH60052	0.3	11.20
XL	Perfect Fit	FH60053	0.3	11.20

PROFLEX® ANTIVIBRATION AND IMPACT GLOVES

Half-Finger Impact

Improved vibration damping, comfort, and dexterity help reduce the risk of hand-arm vibration syndrome. Comfortable design doesn't compromise dexterity; incorporates split-grain pigskin, breathable stretch Spandex, and EVA foam pads. Hook and loop closure. Wicked™ treated for moisture control. Black color. Priced and sold in pairs.



Size	Model	Shpg. Wt.	\$ Each
S	FH60070	0.2	18.35
M	FH60071	0.2	18.35
L	FH60072	0.2	18.35
XL	FH60073	0.2	18.35

INDUSTRIAL SAF-T-TAPE®

Saf-T-Tape® sticks to itself, not to skin or hair, making it a perfect skin protector for industry. Facilitates positive grip during assembly operations, and protects hands and fingers from heat, cuts, or abrasions without loss of finger sensitivity. Safety green color. 30 Yds. per Roll



Tape Size	Rolls Per Pkg.	Model	Shpg. Wt.	\$ Each
3/4"	16	FH60090	1.2	21.30
1"	12	FH60091	1.1	21.30

PROTECTIVE EYEWEAR

Strong polycarbonate wraparound lens is lightweight for extended wear comfort.

- ◆ 99.9% UV protection
- ◆ Meets ANSI Z87.1+ standard



CONDOR™ V

Stylish, visitor safety specs provide economical, easy-wear protection.

- ◆ Flexible spatula temples
- ◆ Universal nose bridge

Type	Lens Color	Frame Color	Model	Shpg. Wt.	\$ Each
Uncoated, nonscratch resistant	Clear	Frosted	FH60100	0.1	1.35
Scratch-resistant coating	Clear	Frosted	FH60101	0.1	1.50
Antifog, Scratch-resistant coating	Clear	Frosted	FH60102	0.1	1.70
Scratch-resistant coating	Gray	Frosted	FH60103	0.1	1.60

FUEL® EYEWEAR

Sleek styling is more attractive to workers and improves compliance. Tough, durable nylon frame. Scratch-resistant, mirrored polycarbonate lenses offer 99.9% UV protection. Include lanyard and microfiber bag. Meet ANSI Z87.1-2003 standards.

- ◆ Vented temples with temple tips
- ◆ Soft nose bridge



Lens Color	Frame Color	Model	Shpg. Wt.	\$ Each
Red Mirror	Metallic Sand	FH60110	0.1	22.35
Blue Mirror	Silver	FH60111	0.1	22.35
I/O Mirror	Blue	FH60112	0.1	22.35

PIVOT® EYEWEAR

Advanced frame design offers exceptional coverage and easy lens changes. 2-tone sport styling with a wraparound 8-base lens. Ventilation channels minimize fogging. Conform to ANSI Z87+ and CSA Z94.3 standards.

- ◆ Ratcheting temple for lens angle adjustment
- ◆ Nasal pads help prevent slipping



Lens Color	Frame Color	Model	Shpg. Wt.	\$ Each
Clear	Black/Silver	FH60120	0.1	7.65
Gray	Black/Silver	FH60121	0.1	8.80
Blue Ice Mirror	Black/Silver	FH60122	0.1	9.05

FACE PROTECTION

WILLSON PROTECTO-SHIELD®

Headgear with Universal Visor

Feature Pro-Lok® system to securely attach visor to headgear, eliminating exposure to wearer. Visor protects against chemical splash, spray, and flying particles. Reinforced edge deters cracks and scratches. Ratchet adjustment ensures fit for all head sizes. Meets ANSI Z87.1-2003 standard.



OAL Size (in.)	Model	Shpg. Wt.	\$ Each
8.5"x15"x0.06"	FH60130	0.9	19.65

Replacement Visor

8.5"x15"x0.06"	FH60131	0.6	6.00
----------------	----------------	-----	------

CAPS, HATS, AND ACCESSORIES

Polyethylene shell with Fas-Trac® (knob adjustment) suspension. Dielectric hats and caps meet or exceed applicable requirements for a Type I helmet (top impact) as outlined in ANSI Z89.1-2003, Class E and G. Size 6 1/2 to 8.



V-GARD® SLOTTED CAP

- ◆ **Available colors:** White(0), Blue(1), Yellow(2), Orange(3), Green(4), Red(5), Hi-Viz Orange(6), Hi-Viz Yellow Green(7), White USA Flag(8)



V-GARD® NONSLOTTED HATS

- ◆ **Available colors:** White(0), Yellow(2), Red(5), Blue(1), Green(4), Hi-Viz Orange(6)

Style	Model	Shpg. Wt.	\$ Each
V-Gard® Slotted Cap	FH6015	0.9	11.50
V-Gard® Nonslotted Hat	FH6016	1.0	15.20

Accessories

Fast-Trac® Replacement Suspension	FH60166	0.2	9.00
-----------------------------------	----------------	-----	------

CHILL-ITS® TEMP. CONTROL PRODUCTS

Activate easily when soaked in cold water for 20 to 30 minutes; remain hydrated for 24 to 48 hours.



Color	Model	FH60180	FH60183	Shpg. Wt.	\$ Each
Bandanna					
Red Western	FH60180			0.1	4.15
Blue Western	FH60181			0.1	4.15
Stars & Stripes	FH60182			0.1	4.15
Triangle Hat					
Red Western	FH60183			0.1	4.15
Blue Western	FH60184			0.1	.15

SWEATBANDS

Soft, reinforced sponge absorbs perspiration.

Waffled sponge provides added durability with gauze scrim-reinforced design. Industrial-grade elastic band stitched into sponge. 8 5/8 x 1 3/4".



Qty. Per Bag	Model	FH60185	Shpg. Wt.	\$ Each
100	FH60185		1.9	38.40

PROFLEX® ECONOMY BACK SUPPORT

Adjustable 2-stage closure adjusts first for exact fit, then for desired tension level. Black color.

- ◆ 280-denier 8" body cloth
- ◆ 1 1/2" Knit Elastic Suspenders



Size	Fits Waist (in.)	Model	Shpg. Wt.	\$ Each
M	30-34	FH60190	0.7	11.75
L	34-38	FH60191	0.7	11.75
XL	38-42	FH60192	0.8	11.75
XXL	42-46	FH60193	0.9	11.75

ONE TOUCH™ EAR PLUG DISPENSING SYSTEM AND REFILL

Patented "no waste funnel" allows users to reuse both the base and the dispensing unit. Accepts different bottles of ear plugs based on desired NRR rating. EarSoft® Blast™ plugs feature the highest attenuation available. Dispensing bottle and base sold separately.



Description	Plug Color	Noise Reduction Rating (dB)	Pairs Per Bottle	Model	Shpg. Wt.	\$ Each
E-A-R EarSoft® Blast™ Dispenser Bottle	Yellow/Orange	33	500	FH60200	1.3	65.00
One Touch Dispenser Base (blue)	—	—	—	FH60201	2.35	33.00

REUSABLE EAR PLUGS

More economical than disposable plugs, with the same comfort and protection. All are attenuation tested in accordance with ANSI S3.19-1974.



FUSION® QUADRUPLE-FLANGED

FlexiFirm® core ensures easy insertion and patented quadruple SoftFlange™ design adjusts in ear to provide a tight seal. Detachable cord.

Description	Plug Color	Noise Reduction Rating (dB)	Pairs Per Box	Brand	Model	Shpg. Wt.	\$ Each
Ear Plug w/Case	Blue/Yellow	27	100	Howard Leight	FH60202	1.4	109.00

3M™ RESPIRATORS

GENERAL INDUSTRIAL PARTICULATE RESPIRATOR

For use in bagging, drilling, grinding, machining, sanding, sawing, processing of minerals, and grain handling.

LIGHT-DUTY RESPIRATOR

Lightweight construction and 3M's patented filter media make this a perfect choice for light duty and/or short-duration work.

Desc.	Filter Class	Pkg. Qty.	Model	Shpg. Wt.	\$ Each
Gen. Indst.	N95	20	FH60230	0.6	21.75
Light-Duty	N95	20	FH60231	0.5	17.45

KNEE PADS



Desc.	Model	Shpg. Wt.	\$ Each
Round Molded	FH60260	1.2	8.90
Nonskid, Non-marring	FH60261	1.5	18.85
Easy Swivel Professional	FH60262	1.7	36.75

SAFETY SWITCH

This rocker-type safety switch mounts directly to the REBEL® router table or any work bench. Red plastic switch cover is a removable key to lock switch in the OFF position when not in use. Includes 7' grounded electrical cord.



Desc.	Model	Shpg. Wt.	\$ Each
Safety Switch	FH60300	0.92	14.00

PADDLE SWITCH 110V

This Paddle Switch provides a greater degree of safety over other types of 110V on/off switches due to its oversize paddle and removable lock-out key. No more fumbling around to locate the off button. Simply slap the paddle down to switch off power. Fits 7/8" x 1-1/2" openings. 110V, 20 Amp.



Desc.	Model	Shpg. Wt.	\$ Each
Paddle Switch	FH60301	0.1	5.00

MODULAR CABLE PROTECTION SYSTEMS

Strong, nonmetallic design safeguards electrical cables and cords from vehicles and pedestrians.

- ♦ All-weather indoor/outdoor polyurethane
- ♦ High visibility yellow liftcover and caps
- ♦ Safe passage for vehicles and pedestrians



TRUKTRAK®

For heavy traffic and heavy-duty applications-supports trucks and forklifts.

TREDTRAK®

Supports pedestrian and light vehicles traffic while protecting cable up to 1.28" (32.5mm) Can be extended to any length by combining tracks.

Description	L x W x H (In.)	Channel Dim W x H (In.)	Load Capacity @ 70°F/120°F	Model	Shpg.	
					Wt.	\$ Each
5-Channel, TrukTrak®	36x20x2.31	1.25x1.25	20,250/9,200	FH60320	32.0	475.00
5-Channel, TredTrak®	36x17.5x1.95	1.3x1.3	10,500/6,500	FH60321	18.0	310.00
3-Channel, TredTrak®	36x20x3.05	2.25x2.25	14,210/4,653	FH60322	34.3	595.00
2-Channel, TredTrak®	36x22x4.13	3.25x3.25	10,880/2,095	FH60323	46.4	775.00

SHOP FLASH™

Never miss an important phone call while working in a noisy shop environment. Perfect for workshops with loud machinery running or when wearing hearing protection. Built-in audible sound or flashing light or both will alert you every time the phone rings. The Shop Flash™ requires no batteries and includes AC/DC adapter and microphone with 14' cord that easily attaches to your telephone.



Desc.	Model	Shpg. Wt.	\$ Each
Shop Flash	FH60330	1.68	29.00

STRAIGHT BLADE PLUGS & CONNECTORS

Dual-LED indicators provide immediate visual identification of potential upstream mis-wire conditions. Nylon housing provides superior chemical and impact resistance, with an integral dust seal to keep contaminants out. Single-plane wiring for easy installation. Black and white color. Meet cULus and FSUL Standards. 15 Amps., 125 Volts



Desc.	NEMA Configure	Model	Shpg. Wt.	\$ Each
Plug	5-15P	FH60302	0.2	15.45
Connector	5-15R	FH60303	0.2	27.50

POLAR/SOLAR PLUS™ EXTENSION CORDS

These durable cords are bright yellow for high visibility and safe handling on the jobsite. They remain flexible in extreme temperatures and offer superior resistance to moisture and abrasion. For indoor or outdoor use.

- Polar:** For cold weather resistance
- Solar:** For ultraviolet resistance



SINGLE CONNECTOR EXTENSION

Extremely rugged T-Prene® SJEOW jacket resists oil, grease, chemicals, and water, yet weighs less than most cords for easy handling. Cords meet OSHA requirements for outdoor use.

AWG/ Conductor	Cord Length (ft.)	Model	Shpg.	
			Wt.	\$ Each
12/3	50	FH60310	6.2	55.50
12/3	100	FH60311	11.9	105.00

TRI-SOURCE® EXTENSION POLAR/SOLAR PLUS

Extremely rugged T-Prene® SJEOW jacket resists oil, grease, chemicals, and water, yet weighs less than most cords for easy handling. Cords meet OSHA requirements for outdoor use.



AWG/ Conductor	Cord Length (ft.)	Model	Shpg.	
			Wt.	\$ Each
12/3	50	FH60312	6.3	78.50
12/3	100	FH60313	12.1	128.00

SHOP & SAFETY SUPPLIES

SAFETY LOCKOUT CENTERS

Store and dispense lockout/tagout devices for OSHA compliance. Choose from fully equipped lockout centers or unequipped units that allow customization for individual needs.

Deluxe Board- Acrylic board has large pockets to accommodate a variety of lockout safety devices and supplies. Red and black lettering with red stripes on white background. Equipped model includes: 25 lockout training booklets, 20 tags and cable ties, six individually keyed multicolored padlocks, and five 1 1/2" diameter jaw group lockout devices.

Economy Board- Acrylic board is designed for small shops or for multiple locations near machines in large plants. Features six hooks. Black lettering on yellow background. Equipped model includes: six individually-keyed multicolored padlocks, two group lockout hasps (1" and 1 1/2" diameter jaw), and ten lockout tags with cable ties.

Micro Station Board- Compact design for mounting on or close to the machinery or equipment to be locked out. Durable yellow plastic with predrilled holes for wall mounting. Can also be used on table top. Equipped model includes: one steel padlock, one 1 1/2" diameter jaw group lockout hasp, two lockout tags, and five cable ties.

Circuit Breaker Board- Durable plastic board holds only lockout equipment necessary to properly secure breakers in Off position, and can be attached on or near breaker box. Red lettering and stripes on white background. Equipped station includes: two single pole and multipole breaker lockouts, one lockout tag and cable tie, and one padlock.

Operator Lockout Safety Kit- Includes 1 1/2" steel lockout hasp, safety padlock, lockout tag w/tie, single-pole breaker lockout, and lockout safety wallet card. Polyethylene case.

Training Booklet- 16-page booklet assists in basic understanding of lockout practices, devices, procedures, etc. 10 per package.



FH60401

Description (ft.)	H x W x D (in.)	Model	Shpg. Wt.	\$ Each
Deluxe Board	30 x 24 x 4 1/2	FH60400	17.0	230.00
Economy Board	14 x 14 x 1 3/8	FH60401	5.2	125.00
Economy Board, Bilingual	14 x 14 x 1 3/8	FH60402	5.2	138.00
Micro Station	8 x 6 1/4 x 2 3/4	FH60403	2.7	52.50
Circuit Breaker board	8 x 6 1/4 x 2 3/4	FH60404	1.5	50.50
Operator Lockout Safety Kit	5 1/2 x 6 7/8 x 2	FH60405	0.9	33.00
Lockout Training Booklet, English	-	FH60406	0.7	19.50
Lockout Training Booklet, Spanish	-	FH60407	0.7	19.50

STEEL BODY SAFETY LOCKOUT PADLOCKS

Reinforced laminated steel construction. Six bumper colors available for instant identification by department or group. Extra length shackles are offered for a wider range of uses.

- ◆ Precision 4-pin tumbler cylinder
- ◆ Locks keyed differently
- ◆ 2 keys included



Case Dimensions (in.) - 1 1/2 x 3/4

Shackle Size (in.) - H 3/4 x W 5/8

x Dia. 9/32

Bumper Color: Blue, Red, Yellow, Green, Black & White

Color	Model	Shpg. Wt.	\$ Each
"Please Specify"	FH60420	0.5	9.00

SAFETY LOCKOUT HASPS

Lock out equipment by up to six workers at a time. Locking holes accommodate all Master Lock safety lockout padlocks with up to 3/8" shackle diameter. Pry-resistant, heavy-gauge steel construction with bright vinyl insulation coating.



FH60427

Inside Jaw Dia. (in.)	L x W (in.)	Model	Shpg. Wt.	\$ Each
1	4 1/2 x 1 1/2	FH60426	0.2	5.50
1 1/2	5 x 1 1/2	FH60427	0.2	6.50

PLUG LOCKOUTS

Bright yellow "caution" color and tough plastic housing warn against unauthorized plug-ins. Accepts up to 9/16" shackle or nylon tie.

Universal- Locks out any electrical plug up to 3" wide and 5 1/2" long (125V to 600V). Meets current OSHA lockout requirements.

Small- Locks out smaller 110/220V plugs up to 2 1/2" long and 1 3/4" diameter with a maximum cord diameter of 1/2".



FH60440

Description	Model	Shpg. Wt.	\$ Each
Universal	FH60440	0.3	12.50
Small	FH60441	0.2	10.00

FLOOR SIGN

Chemical-resistant polyethylene sign alerts employees that equipment is locked out for service. Printed on both sides. 20H x 12"W. Printed on both sides.



Description	Model	Shpg. Wt.	\$ Each
Floor Sign	FH60442	2.2	23.00

SELF-LAMINATING TAGS

Personalize tags by writing special instructions, hazards, or warnings; then protect and seal your message with the clear, acrylic adhesive overlay. Constructed of durable polyester with a 1-mil. polyester overlay. All have 3/8" brass grommets that accept most padlocks for lockout applications. Measure 5 3/4 x 3", with cable ties. 10 per package.



FH60443 FH60444 FH60445 FH60446

Description	Model	Shpg. Wt.	\$ Each
Caution	FH60443	0.1	17.25
Danger 1	FH60444	0.1	17.25
Danger 2	FH60445	0.1	17.50
Out of Service	FH60446	0.1	17.25

FIRST AID KITS AND STATIONS

Meet ANSI Z308.1-2003 standards. Equipped with carrying handles and mounting brackets. All items are labeled for simplified refill ordering.

UNITIZED KITS

Plastic and weatherproof, to keep supplies clean and dry. Color-coded cartons simplify use and hold individually sealed unit dose applications. Yellow: Bandages, Compresses Blue: Antiseptics, Wound Cleansers Red: Burn Treatment Green: Special, Miscellaneous Orange: Personal Protection

BULK KITS

Contain larger volumes of frequently used items, for greater economy. Plastic construction.

FIRST AID STATIONS

Contain large quantities of first aid and medical supplies for most minor injuries, aches, and pains. Rustproof steel construction.



People Served	Bandages	Qty. Medicinal	Qty. Burn	Qty. Eye	D x W x H	Case	Model	Shpg. Wt.	\$ Each
5	22	10	6	0	2 ³ / ₄ x 5 x 8	Plastic	FH60470	1.1	16.25
25	48	18	6	0	3 x 7 x 10 ¹ / ₄	Plastic	FH60471	1.5	20.25
100	357	180	1	5	5 x 11 x 15	Steel	FH60472	18.0	133.00

40- QUART ICE CHEST

Ultratherm® foam insulation provides maximum cold retention. Supports loads up to 300 lbs., and has UV inhibitors to protect against fading. Refrigerator-quality liner is stain- and odor-resistant and easy to clean. Recessed "triple snap" drain plug closure prevents leaks. Swing-up handles stay in place, up or down. Blue body, white lid.



Capacity (Qt.)	L x W x H (in.)	Model	Shpg. Wt.	\$ Each
40	24 ¹ / ₄ x 13 ³ / ₄ x 14	FH60500	10.2	39.00

LEGEND AND ELITE BEVERAGE COOLERS

Ultratherm® insulation keeps drinks cold. Feature flip-top spout with side-pull action for easy cleaning. Inner lining resists stains and odors, and is easy to clean. Integrated handle eases carrying and pouring.



Capacity (Gal.)	L x W x H (in.)	Model	Shpg. Wt.	\$ Each
1/2	6 ¹ / ₄ x 6 x 11 ³ / ₈	FH60501	1.7	7.00
1	8 ³ / ₈ x 8 ³ / ₈ x 8 ³ / ₄	FH60502	1.6	12.00

GATORADE® THIRST QUENCHER MIX

Drink mix helps maintain proper blood electrolyte levels and promotes rehydration by aiding water absorption. Mix powder or liquid concentrate with water per instructions. Dispenser rack with two pumps for concentrate bottles available separately.



Flavor	Yield (Gal.)	Model	Shpg. Wt.	\$ Each
Fierce Grape, Lemon-Lime, Orange, Fruit Punch, Glacier Freeze, Riptide Rush	2.5	FH60520	1.4	4.15
Lemon-Lime, Orange, Fruit Punch, Glacier Freeze, Riptide Rush, Fierce Grape	6	FH60526	3.4	8.90

EMERGENCY EYE/SKIN FLUSH STATIONS

Designed to flush harmful irritants from the eyes and body. Highly visible backplate is easy to find in an emergency. Universal station back plate accommodates 16- and 32-oz. bottles. Include strong mounting tape and hardware.



FH60482

Desc.	Model	Shpg. Wt.	\$ Each
16 Oz. Flush Station	FH60480	2.2	19.00
32 Oz. Flush Station	FH60481	3.0	24.25
Two 32 Oz. Station	FH60482	5.9	43.50
16 Oz. Refill	FH60483	1.2	7.10
32 Oz. Refill	FH60484	2.3	9.55

PORTABLE PLASTIC WATER COOLERS

Handle continual, day-to-day use. Wide-mouth opening makes filling simple and easy. High-visibility safety yellow and red. Rugged exterior, with large grip handles. Ultratherm® foam insulation. FDA-grade material liner for easy cleaning and stain/odor resistance.



Capacity (Gal.)	H x Dia. (in.)	Model	Shpg. Wt.	\$ Each
5	20.5 x 14	FH60540	7.8	39.75
10	23.5 x 16	FH60541	11.4	63.00

CUP DISPENSERS

Fit plastic and metal commercial coolers - simply slide dispenser onto bracket attached to the cooler.



Description	Model	Shpg. Wt.	\$ Each
8-oz. Cup Dispenser	FH60542	0.2	21.00
8-oz. Cup (Sleeve of 250)	FH60543	1.9	12.75

Model Number Index

Model	Page	Model	Page	Model	Page	Model	Page	Model	Page	Model	Page
FH00100.....	27	FH02008.....	34	FH02509.....	36	FH03312.....	43	FH03445.....	44	FH10003.....	51
FH00101.....	27	FH02009.....	34	FH02510.....	36	FH03313.....	43	FH03446.....	44	FH10004.....	51
FH00102.....	27	FH02010.....	34	FH02511.....	36	FH03314.....	43	FH03447.....	44	FH10005.....	51
FH00103.....	27	FH02011.....	34	FH02600.....	36	FH03315.....	43	FH03448.....	44	FH10006.....	61
FH00104.....	27	FH02012.....	34	FH02601.....	36	FH03316.....	43	FH03449.....	44	FH10007.....	61
FH00105.....	27	FH02013.....	34	FH02602.....	36	FH03317.....	43	FH03450.....	44	FH10008.....	61
FH00106.....	27	FH02014.....	34	FH02603.....	36	FH03318.....	43	FH03451.....	44	FH10009.....	61
FH00107.....	27	FH02015.....	34	FH02604.....	36	FH03319.....	43	FH03452.....	44	FH10010.....	61
FH00150.....	27	FH02016.....	34	FH02605.....	36	FH03320.....	43	FH03453.....	44	FH10011.....	61
FH00151.....	27	FH02017.....	34	FH02606.....	36	FH03321.....	43	FH03454.....	44	FH1013.....	42
FH00170.....	27	FH02018.....	34	FH02607.....	36	FH03322.....	43	FH03455.....	44	FH1014.....	42
FH00171.....	27	FH02019.....	35	FH02608.....	36	FH03323.....	43	FH03456.....	44	FH1022.....	42
FH00172.....	27	FH02020.....	35	FH02609.....	36	FH03324.....	43	FH03457.....	44	FH1025A.....	42
FH00173.....	27	FH02021.....	36	FH02610.....	36	FH03325.....	43	FH03458.....	44	FH1025B.....	42
FH01001.....	28	FH02022.....	36	FH02611.....	36	FH03326.....	43	FH03459.....	44	FH1025C.....	42
FH01002.....	28	FH02023.....	34	FH02612.....	36	FH03327.....	43	FH03460.....	44	FH1026.....	42
FH01003.....	28	FH02100.....	35	FH02613.....	36	FH03328.....	43	FH03461.....	44	FH1030.....	42
FH01004.....	28	FH02101.....	35	FH02614.....	36	FH03329.....	43	FH03462.....	44	FH10401.....	43
FH01005.....	28	FH02102.....	35	FH02615.....	36	FH03330.....	43	FH03463.....	44	FH10402.....	43
FH01006.....	28	FH02103.....	35	FH02616.....	36	FH03331.....	43	FH03464.....	44	FH10404.....	43
FH01007.....	28	FH02104.....	35	FH02617.....	36	FH03332.....	43	FH03465.....	44	FH10406.....	43
FH01008.....	28	FH02105.....	35	FH02618.....	36	FH03400.....	44	FH03466.....	44	FH10408.....	43
FH01009.....	29	FH02106.....	35	FH02619.....	36	FH03401.....	44	FH03467.....	44	FH1058.....	42
FH01010.....	29	FH02200.....	36	FH03000.....	42	FH03402.....	44	FH03468.....	44	FH1062.....	42
FH01011.....	28	FH02201.....	36	FH03001.....	42	FH03403.....	44	FH03469.....	44	FH1063.....	42
FH01050.....	29	FH02202.....	36	FH03002.....	42	FH03404.....	44	FH03470.....	44	FH1065L.....	42
FH01051.....	29	FH02203.....	36	FH03003.....	42	FH03405.....	44	FH03471.....	44	FH1067.....	42
FH01100.....	29	FH02204.....	36	FH03004.....	42	FH03409.....	44	FH03472.....	44	FH1069.....	42
FH01150.....	30	FH02205.....	36	FH03005.....	42	FH03410.....	44	FH03473.....	44	FH1072.....	42
FH01151.....	30	FH02206.....	36	FH03006.....	42	FH03411.....	44	FH03474.....	44	FH1073.....	42
FH01152.....	30	FH02207.....	36	FH03007.....	42	FH03412.....	44	FH03475.....	44	FH1077.....	42
FH01170.....	31	FH02300.....	36	FH03008.....	42	FH03413.....	44	FH03476.....	44	FH1085.....	42
FH01171.....	31	FH02301.....	36	FH03009.....	42	FH03414.....	44	FH03477.....	44	FH1094.....	42
FH01172.....	31	FH02302.....	36	FH03010.....	42	FH03415.....	44	FH03478.....	44	FH11000.....	51
FH01180.....	29	FH02303.....	36	FH03011.....	42	FH03416.....	44	FH03479.....	44	FH11001.....	51
FH01181.....	29	FH02304.....	36	FH03012.....	42	FH03417.....	44	FH03480.....	44	FH11002.....	51
FH01182.....	30	FH02305.....	36	FH03013.....	42	FH03418.....	44	FH03481.....	44	FH11003.....	51
FH01200.....	31	FH02306.....	36	FH03014.....	42	FH03419.....	44	FH03500.....	45	FH11004.....	51
FH01201.....	31	FH02307.....	36	FH03015.....	42	FH03420.....	44	FH03501.....	45	FH11005.....	51
FH01202.....	31	FH02308.....	36	FH03016.....	42	FH03421.....	44	FH03502.....	45	FH11006.....	51
FH01203.....	31	FH02309.....	36	FH03017.....	41	FH03422.....	44	FH03503.....	45	FH11007.....	51
FH01204.....	31	FH02310.....	36	FH03200.....	43	FH03423.....	44	FH03504.....	45	FH11008.....	51
FH01205.....	31	FH02311.....	36	FH03201.....	43	FH03424.....	44	FH03505.....	45	FH11009.....	51
FH01206.....	31	FH02312.....	36	FH03202.....	43	FH03425.....	44	FH03506.....	45	FH11010.....	51
FH01207.....	31	FH02313.....	36	FH03203.....	43	FH03426.....	44	FH03507.....	45	FH11050.....	53
FH01211.....	31	FH02400.....	36	FH03204.....	43	FH03427.....	44	FH03508.....	45	FH11051.....	53
FH01212.....	31	FH02401.....	36	FH03205.....	43	FH03428.....	44	FH03509.....	45	FH11052.....	53
FH01213.....	31	FH02402.....	36	FH03206.....	43	FH03429.....	44	FH03510.....	45	FH11053.....	53
FH01214.....	31	FH02403.....	36	FH03207.....	43	FH03430.....	44	FH03511.....	45	FH11054.....	53
FH01215.....	31	FH02404.....	36	FH03208.....	43	FH03431.....	44	FH03512.....	45	FH11055.....	53
FH01216.....	31	FH02405.....	36	FH03209.....	43	FH03432.....	44	FH03513.....	45	FH116401.....	45
FH01500.....	32	FH02406.....	36	FH03300.....	43	FH03433.....	44	FH03514.....	45	FH1203.....	38
FH01501.....	32	FH02407.....	36	FH03301.....	43	FH03434.....	44	FH03515.....	45	FH12400-5.....	50
FH01502.....	32	FH02408.....	36	FH03302.....	43	FH03435.....	44	FH03516.....	45	FH12402-5.....	50
FH01503.....	32	FH02500.....	36	FH03303.....	43	FH03436.....	44	FH03517.....	45	FH12470-5.....	50
FH02000.....	34	FH02501.....	36	FH03304.....	43	FH03437.....	44	FH03518.....	45	FH12478-5.....	50
FH02001.....	34	FH02502.....	36	FH03305.....	43	FH03438.....	44	FH03519.....	45	FH12508.....	47
FH02002.....	34	FH02503.....	36	FH03306.....	43	FH03439.....	44	FH03520.....	45	FH12509.....	47
FH02003.....	34	FH02504.....	36	FH03307.....	43	FH03440.....	44	FH03521.....	45	FH12515.....	47
FH02004.....	34	FH02505.....	36	FH03308.....	43	FH03441.....	44	FH03522.....	45	FH12516.....	47
FH02005.....	34	FH02506.....	36	FH03309.....	43	FH03442.....	44	FH03523.....	45	FH12517.....	47
FH02006.....	34	FH02507.....	36	FH03310.....	43	FH03443.....	44	FH03524.....	45	FH12518.....	47
FH02007.....	34	FH02508.....	36	FH03311.....	43	FH03444.....	44	FH10001.....	51	FH12520.....	47

Model	Page	Model	Page	Model	Page	Model	Page	Model	Page	Model	Page
FH12521.....	47	FH20017.....	58	FH30109.....	62	FH33614-2G.....	57	FH40342.....	73	FH41602.....	92
FH12522.....	47	FH20018.....	58	FH30110.....	62	FH33618-2G.....	57	FH40343.....	73	FH41603.....	92
FH12523.....	47	FH20019.....	58	FH30111.....	62	FH33-890.....	46	FH40360.....	73	FH41604.....	92
FH12524.....	47	FH20020.....	58	FH30112.....	62	FH35000.....	67	FH40380.....	74	FH41605.....	92
FH12525.....	47	FH20021.....	58	FH30113.....	62	FH35010.....	67	FH40381.....	74	FH41606.....	92
FH12527.....	47	FH20022.....	58	FH30200.....	62	FH35100.....	70	FH40382.....	74	FH41607.....	92
FH12528.....	47	FH20023.....	58	FH30201.....	62	FH35101.....	70	FH40400.....	74	FH41608.....	92
FH12529.....	47	FH20024.....	58	FH30202.....	62	FH35102.....	70	FH40401.....	74	FH41609.....	92
FH12530.....	47	FH20025.....	58	FH30203.....	62	FH35103.....	70	FH40402.....	74	FH41610.....	92
FH1274DVS.....	59	FH20026.....	58	FH30204.....	62	FH35104.....	70	FH40403.....	74	FH41611.....	92
FH1276DVS.....	59	FH20027.....	58	FH30205.....	62	FH35105.....	70	FH40404.....	74	FH41612.....	92
FH1297DK.....	59	FH20028.....	58	FH30206.....	62	FH35106.....	70	FH40405.....	74	FH41613.....	92
FH1300.....	39	FH20029.....	58	FH30207.....	62	FH35107.....	70	FH40406.....	74	FH41614.....	92
FH1301.....	39	FH20030.....	58	FH30208.....	62	FH35108.....	70	FH40407.....	74	FH41615.....	92
FH1302.....	39	FH20031.....	58	FH30209.....	62	FH35109.....	70	FH40408.....	74	FH41616.....	92
FH1303.....	39	FH20032.....	58	FH30210.....	62	FH35110.....	70	FH40409.....	74	FH41617.....	92
FH131000.....	39	FH20033.....	58	FH30250.....	63	FH35111.....	70	FH40410.....	101	FH41618.....	92
FH131125.....	39	FH20034.....	58	FH30251.....	63	FH35112.....	70	FH40440.....	74	FH41619.....	92
FH131250.....	39	FH20035.....	58	FH30252.....	63	FH35113.....	71	FH40441.....	74	FH41620.....	92
FH131250-516.....	39	FH20036.....	58	FH30253.....	63	FH35114.....	71	FH40442.....	75	FH41621.....	92
FH13500.....	39	FH20037.....	58	FH30254.....	63	FH35115.....	71	FH40450.....	74	FH41622.....	92
FH13596.....	59	FH20038.....	58	FH30255.....	63	FH35116.....	71	FH40451.....	74	FH41623.....	92
FH13597.....	59	FH20039.....	58	FH30256.....	63	FH35117.....	71	FH40452.....	74	FH41624.....	92
FH13618-2G.....	57	FH20040.....	58	FH31000.....	64	FH35118.....	71	FH40453.....	74	FH41625.....	92
FH13625.....	39	FH20041.....	58	FH31001.....	64	FH35119.....	71	FH41200.....	90	FH41626.....	92
FH136401.....	45	FH20042.....	58	FH31002.....	64	FH35120.....	71	FH41201.....	90	FH41627.....	92
FH13750.....	39	FH20043.....	58	FH31003.....	64	FH35121.....	71	FH41202.....	90	FH41628.....	93
FH13812.....	39	FH20044.....	58	FH31004.....	64	FH35122.....	71	FH41203.....	90	FH41629.....	93
FH13875.....	39	FH20045.....	58	FH31005.....	64	FH35123.....	71	FH41204.....	90	FH41630.....	93
FH14043-3.....	50	FH20046.....	58	FH31006.....	64	FH35124.....	71	FH41320.....	103	FH41631.....	93
FH14045-5.....	50	FH20047.....	58	FH31007.....	64	FH352VS.....	59	FH41321.....	103	FH41632.....	93
FH14050-5.....	50	FH20048.....	58	FH31008.....	64	FH35-7670.....	46	FH41322.....	103	FH41633.....	93
FH14051-3.....	50	FH20049.....	58	FH31009.....	64	FH36-953.....	46	FH41323.....	103	FH41634.....	93
FH14060-5.....	50	FH20300.....	59	FH31010.....	64	FH36-953B.....	46	FH41324.....	103	FH41635.....	93
FH14068-5.....	50	FH20301.....	59	FH31011.....	64	FH39500.....	71	FH41325.....	103	FH41636.....	93
FH14080-5.....	50	FH20302.....	59	FH31012.....	64	FH39501.....	71	FH41326.....	103	FH41637.....	93
FH14085-5.....	50	FH20303.....	59	FH31013.....	64	FH39502.....	71	FH41327.....	103	FH41638.....	93
FH14087-5.....	50	FH20304.....	59	FH31017.....	65	FH39503.....	71	FH41328.....	103	FH41639.....	93
FH14088-3.....	50	FH20400.....	59	FH31018.....	65	FH39600.....	71	FH41400.....	90	FH41640.....	93
FH14AFAD.....	85	FH20401.....	59	FH31019.....	65	FH39601.....	71	FH41401.....	90	FH41641.....	93
FH14AFST.....	85	FH20402.....	59	FH31020.....	65	FH40100.....	72	FH41500.....	91	FH41800.....	93
FH1587AVSK.....	47	FH20403.....	59	FH31021.....	65	FH40101.....	72	FH41501.....	91	FH41801.....	93
FH1594K.....	55	FH20404.....	59	FH31022.....	65	FH40102.....	72	FH41520.....	91	FH41802.....	93
FH1617PK.....	53	FH20405.....	59	FH31023.....	65	FH40103.....	72	FH41521.....	91	FH41803.....	93
FH16250K-2.....	65	FH20406.....	59	FH31024.....	65	FH40104.....	72	FH41522.....	91	FH41804.....	93
FH1920914.....	38	FH20407.....	59	FH31025.....	65	FH40105.....	72	FH41523.....	91	FH41805.....	93
FH19210.....	38	FH20408.....	59	FH31026.....	65	FH40106.....	72	FH41524.....	91	FH41806.....	93
FH20001.....	58	FH20409.....	59	FH31027.....	65	FH40150.....	72	FH41540.....	91	FH41807.....	93
FH20002.....	58	FH20410.....	59	FH31028.....	65	FH40151.....	72	FH41541.....	91	FH41808.....	93
FH20003.....	58	FH20411.....	59	FH31029.....	65	FH40152.....	72	FH41542.....	91	FH41809.....	93
FH20004.....	58	FH20412.....	59	FH31030.....	65	FH40200.....	73	FH41543.....	91	FH41810.....	93
FH20005.....	58	FH20413.....	59	FH31031.....	65	FH40201.....	73	FH41544.....	91	FH41811.....	93
FH20006.....	58	FH20414.....	59	FH31032.....	65	FH40202.....	73	FH41545.....	91	FH41812.....	93
FH20007.....	58	FH20415.....	59	FH31033.....	65	FH40250.....	73	FH41546.....	91	FH41813.....	93
FH20008.....	58	FH28WW.....	65	FH31034.....	65	FH40251.....	73	FH41547.....	91	FH41814.....	93
FH20009.....	58	FH30101.....	62	FH31035.....	65	FH40300.....	73	FH41548.....	91	FH41815.....	93
FH20010.....	58	FH30102.....	62	FH31036.....	65	FH40301.....	73	FH41549.....	91	FH41890.....	93
FH20011.....	58	FH30103.....	62	FH31037.....	65	FH40302.....	73	FH41550.....	91	FH41891.....	93
FH20012.....	58	FH30104.....	62	FH31038.....	65	FH40320.....	73	FH41590.....	91	FH41892.....	93
FH20013.....	58	FH30105.....	62	FH31039.....	65	FH40301.....	73	FH41591.....	91	FH41893.....	93
FH20014.....	58	FH30106.....	62	FH31040.....	65	FH40320.....	73	FH41592.....	91	FH41900.....	93
FH20015.....	58	FH30107.....	62	FH31041.....	65	FH40340.....	73	FH41600.....	92	FH42000.....	94
FH20016.....	58	FH30108.....	62	FH324MAG.....	49	FH40341.....	73	FH41601.....	92	FH42001.....	94

Model Number Index

Model	Page	Model	Page	Model	Page	Model	Page	Model	Page	Model	Page
FH42002.....	94	FH43103.....	41	FH43824.....	40	FH45018.....	97	FH45081.....	80	FH46604.....	98
FH42010.....	94	FH43109.....	40	FH44010.....	75	FH45019.....	97	FH45082.....	80	FH46605.....	98
FH42020.....	94	FH43118.....	40	FH44011.....	75	FH45020.....	97	FH45083.....	80	FH46700.....	98
FH42021.....	41	FH43127.....	41	FH44012.....	75	FH45021.....	97	FH45084.....	80	FH46701.....	98
FH42022.....	94	FH43133.....	41	FH44013.....	75	FH45022.....	97	FH45085.....	80	FH46702.....	98
FH42023.....	94	FH43145.....	41	FH44014.....	75	FH45023.....	97	FH45086.....	80	FH46703.....	98
FH42024.....	41	FH43147.....	41	FH44015.....	75	FH45024.....	97	FH45087.....	80	FH46704.....	98
FH42027.....	41	FH43174.....	41	FH44016.....	76	FH45025.....	97	FH45088.....	80	FH46705.....	98
FH42030.....	41	FH43190.....	41	FH44017.....	76	FH45026.....	97	FH45089.....	80	FH46706.....	98
FH42033.....	41	FH43207.....	40	FH44018.....	76	FH45027.....	97	FH45090.....	80	FH46710.....	98
FH42036.....	41	FH43210.....	40	FH44019.....	76	FH45028.....	97	FH45091.....	80	FH46711.....	98
FH42039.....	41	FH43213.....	41	FH44020.....	76	FH45029.....	97	FH45092.....	80	FH46712.....	98
FH42042.....	41	FH43214.....	40	FH44021.....	76	FH45030.....	97	FH45093.....	80	FH46713.....	98
FH42045.....	41	FH43215.....	40	FH44022.....	76	FH45031.....	97	FH45094.....	80	FH46800.....	98
FH42046.....	41	FH43216.....	40	FH44023.....	76	FH45032.....	97	FH45095.....	80	FH46801.....	98
FH42048.....	41	FH43252.....	40,41	FH44024.....	76	FH45033.....	97	FH45096.....	80	FH46802.....	98
FH42100.....	95	FH43276.....	40	FH44025.....	76	FH45034.....	97	FH45097.....	80	FH46803.....	98
FH42101.....	95	FH43286.....	40	FH44026.....	76	FH45035.....	97	FH45098.....	80	FH46804.....	98
FH42102.....	95	FH43289.....	40	FH44027.....	76	FH45036.....	97	FH45500.....	96	FH47000.....	99
FH42103.....	95	FH43290.....	40	FH44028.....	76	FH45037.....	97	FH45501.....	96	FH47001.....	99
FH42104.....	95	FH43300.....	40	FH44029.....	76	FH45038.....	97	FH45502.....	96	FH47002.....	99
FH42105.....	95	FH43312.....	40	FH44030.....	76	FH45039.....	97	FH45503.....	96	FH47003.....	99
FH42106.....	95	FH43318.....	40	FH44031.....	76	FH45040.....	97	FH45504.....	96	FH47004.....	99
FH4212L.....	48	FH43319.....	40	FH44032.....	77	FH45041.....	97	FH45505.....	96	FH47005.....	99
FH42200.....	95	FH43325.....	41	FH44033.....	77	FH45042.....	97	FH45506.....	96	FH47006.....	99
FH42201.....	95	FH43333.....	40	FH44034.....	77	FH45043.....	97	FH45507.....	96	FH47007.....	99
FH42202.....	95	FH43367.....	41	FH44035.....	77	FH45044.....	97	FH45508.....	96	FH47008.....	99
FH42203.....	95	FH43402.....	41	FH44036.....	77	FH45045.....	97	FH45509.....	96	FH47100.....	99
FH42204.....	95	FH43405.....	41	FH44037.....	77	FH45046.....	97	FH45510.....	96	FH47101.....	99
FH42205.....	95	FH43408.....	41	FH44038.....	77	FH45047.....	97	FH45511.....	96	FH47102.....	99
FH42206.....	95	FH43410.....	41	FH44039.....	77	FH45048.....	97	FH45512.....	96	FH47103.....	99
FH42207.....	95	FH43413.....	41	FH44040.....	77	FH45049.....	97	FH45513.....	96	FH47104.....	99
FH42208.....	95	FH43421.....	41	FH44041.....	77	FH45050.....	97	FH45514.....	96	FH47105.....	99
FH42209.....	95	FH43425.....	41	FH44042.....	77	FH45051.....	97	FH46000.....	81	FH47106.....	99
FH42210.....	95	FH43427.....	41	FH44043.....	77	FH45052.....	97	FH46001.....	81	FH47107.....	99
FH42211.....	95	FH43428.....	41	FH44044.....	77	FH45053.....	78	FH46002.....	81	FH47108.....	99
FH42212.....	95	FH43437.....	39,41	FH44045.....	77	FH45054.....	78	FH46003.....	81	FH47109.....	99
FH42213.....	95	FH43440.....	39	FH44046.....	77	FH45055.....	78	FH46004.....	81	FH47110.....	99
FH42234.....	54	FH43442.....	41	FH44047.....	77	FH45056.....	78	FH46005.....	81	FH47111.....	99
FH42237.....	41	FH43512.....	40	FH44048.....	77	FH45057.....	78	FH46006.....	81	FH47112.....	99
FH42500.....	94	FH43671.....	41	FH44049.....	77	FH45058.....	78	FH46007.....	81	FH47200.....	99
FH42501.....	94	FH43698.....	39	FH44050.....	78	FH45059.....	78	FH46008.....	81	FH47201.....	99
FH42502.....	94	FH43699.....	39	FH44051.....	78	FH45060.....	78	FH46009.....	81	FH47202.....	99
FH42503.....	94	FH43700.....	39	FH44052.....	78	FH45061.....	78	FH46010.....	81	FH47203.....	99
FH42504.....	94	FH43701.....	39	FH4410L.....	48	FH45062.....	78	FH46011.....	81	FH47204.....	99
FH42505.....	94	FH43703.....	39	FH45000.....	75	FH45063.....	78	FH46012.....	81	FH47205.....	99
FH42506.....	94	FH43704.....	39	FH45001.....	75	FH45064.....	79	FH46013.....	81	FH47500.....	101
FH42507.....	94	FH43705.....	41	FH45002.....	75	FH45065.....	79	FH46014.....	81	FH47501.....	101
FH42508.....	94	FH43708.....	40	FH45003.....	75	FH45066.....	79	FH46015.....	81	FH47502.....	101
FH42590.....	94	FH43711.....	40	FH45004.....	75	FH45067.....	79	FH46016.....	81	FH47503.....	101
FH42950.....	54	FH43711.....	40	FH45005.....	75	FH45068.....	79	FH46017.....	81	FH47504.....	101
FH43002.....	54	FH43719.....	40	FH45006.....	75	FH45069.....	79	FH46018.....	81	FH47600.....	101
FH43051.....	40	FH43720.....	40	FH45007.....	75	FH45070.....	79	FH46019.....	81	FH47601.....	101
FH43052.....	40	FH43721.....	40	FH45008.....	75	FH45071.....	79	FH46020.....	81	FH47602.....	101
FH43057.....	40	FH43722.....	40	FH45009.....	75	FH45072.....	79	FH46021.....	81	FH47603.....	101
FH43058.....	40	FH43725.....	41	FH45010.....	97	FH45073.....	79	FH46500.....	98	FH47604.....	101
FH43063.....	40	FH43730.....	40	FH45011.....	97	FH45074.....	79	FH46501.....	98	FH48000.....	101
FH43064.....	40	FH43731.....	40	FH45012.....	97	FH45075.....	79	FH46502.....	98	FH48001.....	101
FH43072.....	41	FH43736.....	39	FH45013.....	97	FH45076.....	79	FH46503.....	98	FH48002.....	101
FH43077.....	41	FH43737.....	39	FH45014.....	97	FH45077.....	79	FH46600.....	98	FH48003.....	101
FH43082.....	41	FH43745.....	39	FH45015.....	97	FH45078.....	79	FH46601.....	98	FH48004.....	101
FH43091.....	41	FH43802.....	40	FH45016.....	97	FH45079.....	79	FH46602.....	98	FH48005.....	101
FH43092.....	41	FH43820.....	40	FH45017.....	97	FH45080.....	80	FH46603.....	98	FH48006.....	101

Model	Page	Model	Page	Model	Page	Model	Page	Model	Page	Model	Page
FH48050.....	101	FH50512.....	89	FH51200.....	102	FH55200.....	105	FH56801.....	108	FH60131.....	110
FH48051.....	101	FH50513.....	89	FH51201.....	102	FH55201.....	105	FH56802.....	108	FH60150.....	110
FH48052.....	101	FH50514.....	89	FH51202.....	102	FH55202.....	105	FH56803.....	108	FH60151.....	110
FH48500.....	101	FH50515.....	89	FH51203.....	102	FH55250.....	105	FH57000.....	108	FH60152.....	110
FH48600.....	82	FH50516.....	89	FH51209.....	103	FH55251.....	105	FH57001.....	108	FH60153.....	110
FH48601.....	82	FH50517.....	89	FH51210.....	103	FH55252.....	105	FH57020.....	108	FH60154.....	110
FH48602.....	82	FH50518.....	89	FH51211.....	103	FH55270.....	105	FH57021.....	108	FH60155.....	110
FH48603.....	82	FH50519.....	89	FH51215.....	103	FH55271.....	105	FH57022.....	108	FH60156.....	110
FH48604.....	82	FH50520.....	89	FH51216.....	103	FH55272.....	105	FH57040.....	108	FH60157.....	110
FH48605.....	82	FH50521.....	89	FH51220.....	103	FH55273.....	105	FH57050.....	108	FH60158.....	110
FH48606.....	82	FH50522.....	89	FH51221.....	103	FH55274.....	105	FH57051.....	108	FH60160.....	110
FH48607.....	82	FH50523.....	89	FH51225.....	103	FH56000.....	105	FH57052.....	108	FH60161.....	110
FH48608.....	82	FH50524.....	90	FH51226.....	103	FH56001.....	105	FH57053.....	108	FH60162.....	110
FH48609.....	82	FH50525.....	90	FH51230.....	103	FH56002.....	105	FH57054.....	108	FH60163.....	110
FH48610.....	82	FH50526.....	90	FH51231.....	103	FH56003.....	105	FH57055.....	108	FH60164.....	110
FH48611.....	82	FH50527.....	90	FH51232.....	103	FH56100.....	105	FH57070.....	108	FH60165.....	110
FH48612.....	82	FH50528.....	90	FH51233.....	103	FH56101.....	105	FH57071.....	108	FH60166.....	110
FH48613.....	82	FH50529.....	90	FH51240.....	103	FH56102.....	105	FH57072.....	108	FH60180.....	111
FH48614.....	82	FH50530.....	90	FH51241.....	103	FH56103.....	105	FH57073.....	108	FH60181.....	111
FH48800.....	83	FH50531.....	90	FH51250.....	103	FH56104.....	105	FH57074.....	108	FH60182.....	111
FH48801.....	83	FH50532.....	90	FH51251.....	103	FH56105.....	105	FH57075.....	108	FH60183.....	111
FH48802.....	83	FH50533.....	90	FH51252.....	103	FH56106.....	105	FH57090.....	108	FH60184.....	111
FH48850.....	83	FH50534.....	90	FH51253.....	103	FH56107.....	105	FH57091.....	108	FH60185.....	111
FH48851.....	83	FH50535.....	90	FH51254.....	103	FH56200.....	106	FH57092.....	108	FH60190.....	111
FH48852.....	83	FH50536.....	90	FH51270.....	103	FH56201.....	106	FH59370.....	33	FH60191.....	111
FH48853.....	83	FH50537.....	90	FH51271.....	103	FH56202.....	106	FH59375.....	33	FH60192.....	111
FH48854.....	83	FH50538.....	90	FH51272.....	103	FH56203.....	106	FH59381.....	33	FH60193.....	111
FH48855.....	83	FH50539.....	90	FH51273.....	103	FH56204.....	106	FH60001.....	109	FH60200.....	111
FH48856.....	83	FH50540.....	90	FH51274.....	103	FH56205.....	106	FH60002.....	109	FH60201.....	111
FH48857.....	83	FH50541.....	90	FH51275.....	103	FH56206.....	106	FH60003.....	109	FH60202.....	111
FH48858.....	83	FH50542.....	90	FH51276.....	103	FH56207.....	106	FH60020.....	109	FH60230.....	111
FH48859.....	83	FH50543.....	90	FH51300.....	103	FH56401.....	45	FH60021.....	109	FH60231.....	111
FH48860.....	83	FH50544.....	90	FH51301.....	103	FH56500.....	107	FH60022.....	109	FH60260.....	111
FH48861.....	83	FH50545.....	90	FH51302.....	103	FH56501.....	107	FH60023.....	109	FH60261.....	111
FH48862.....	83	FH50546.....	90	FH51303.....	103	FH56502.....	107	FH60024.....	109	FH60262.....	111
FH48863.....	83	FH50547.....	90	FH51304.....	103	FH56503.....	107	FH60040.....	109	FH60300.....	112
FH48864.....	83	FH50548.....	90	FH51305.....	103	FH56504.....	107	FH60041.....	109	FH60301.....	112
FH48865.....	83	FH50549.....	90	FH51306.....	103	FH56505.....	107	FH60042.....	109	FH60302.....	112
FH48900.....	83	FH50550.....	90	FH51307.....	103	FH56506.....	107	FH60050.....	109	FH60303.....	112
FH48901.....	83	FH51000.....	90	FH51308.....	103	FH56507.....	107	FH60051.....	109	FH60310.....	112
FH48902.....	83	FH51001.....	90	FH5412L.....	48	FH56508.....	107	FH60052.....	109	FH60311.....	112
FH48903.....	83	FH51002.....	90	FH55000.....	104	FH56509.....	107	FH60053.....	109	FH60312.....	112
FH50010.....	102	FH51003.....	90	FH55001.....	104	FH56550.....	107	FH60070.....	109	FH60313.....	112
FH50011.....	102	FH51004.....	90	FH55002.....	104	FH56551.....	107	FH60071.....	109	FH60320.....	112
FH50012.....	102	FH51005.....	90	FH55003.....	104	FH56552.....	107	FH60072.....	109	FH60321.....	112
FH50013.....	102	FH51006.....	90	FH55004.....	104	FH56553.....	107	FH60073.....	109	FH60322.....	112
FH50014.....	102	FH51007.....	90	FH55005.....	104	FH56554.....	107	FH60090.....	109	FH60323.....	112
FH50015.....	102	FH51008.....	90	FH55006.....	104	FH56555.....	107	FH60091.....	109	FH60330.....	112
FH50100.....	102	FH51009.....	90	FH55007.....	104	FH56600.....	107	FH60095.....	109	FH60400.....	113
FH50101.....	102	FH51010.....	90	FH55008.....	104	FH56601.....	107	FH60096.....	109	FH60401.....	113
FH501215.....	45	FH51011.....	90	FH55100.....	104	FH56650.....	107	FH60097.....	109	FH60402.....	113
FH50500.....	88	FH51012.....	90	FH55101.....	104	FH56651.....	107	FH60100.....	110	FH60403.....	113
FH50501.....	88	FH51013.....	90	FH55102.....	104	FH56652.....	107	FH60101.....	110	FH60404.....	113
FH50502.....	88	FH51014.....	90	FH55103.....	104	FH56653.....	107	FH60102.....	110	FH60405.....	113
FH50503.....	88	FH51015.....	90	FH55104.....	104	FH56654.....	107	FH60103.....	110	FH60406.....	113
FH50504.....	88	FH51016.....	90	FH55105.....	104	FH56655.....	107	FH60110.....	110	FH60407.....	113
FH50505.....	88	FH51017.....	90	FH55106.....	104	FH56656.....	107	FH60111.....	110	FH60420.....	113
FH50506.....	88	FH51018.....	90	FH55107.....	104	FH56700.....	107	FH60112.....	110	FH60421.....	113
FH50507.....	88	FH51019.....	90	FH55108.....	104	FH56701.....	107	FH60120.....	110	FH60422.....	113
FH50508.....	88	FH51020.....	90	FH55109.....	104	FH56750.....	108	FH60121.....	110	FH60423.....	113
FH50509.....	88	FH51050.....	102	FH55110.....	104	FH56751.....	108	FH601215.....	45	FH60424.....	113
FH50510.....	88	FH51051.....	102	FH55111.....	104	FH56752.....	108	FH60122.....	110	FH60425.....	113
FH50511.....	89			FH55168.....	63	FH56800.....	108	FH60130.....	110	FH60425.....	113

Model Number Index

Model	Page	Model	Page	Model	Page	Model	Page	Model	Page	Model	Page
FH60426.....	113	FH80002.....	100	FHDC308K.....	47	FHDW311K.....	50	FHLAT680.....	38	FHPC7519.....	52
FH60427.....	113	FH80003.....	100	FHDC330K.....	47	FHDW3123.....	49	FHLAT690.....	38	FHPC7538.....	53
FH60440.....	113	FH80004.....	100	FHDC385K.....	50	FHDW3128.....	49	FHLAT720.....	38	FHPC7539.....	53
FH60441.....	113	FH80005.....	100	FHDC390K.....	49	FHDW3174.....	49	FHLAT730.....	38	FHPC9543.....	47
FH60442.....	113	FH80006.....	100	FHDC500.....	60	FHDW3176.....	49	FHLAT740.....	38	FHPR10E.....	54
FH60443.....	113	FH80007.....	100	FHDC5001.....	60	FHDW3178.....	49	FHLAT770.....	38	FHPS10-2.....	56
FH60444.....	113	FH80008.....	100	FHDC5001H.....	60	FHDW317K.....	47	FHLAT780.....	38	FHPS20-2.....	56
FH60445.....	113	FH80009.....	100	FHDC509.....	60	FHDW3191.....	49	FHLAT780-3.....	38	FHPS40-2.....	56
FH60446.....	113	FH80010.....	100	FHDC5151.....	60	FHDW3325.....	49	FHLAT790.....	38	FHRBS03.....	40
FH60470.....	114	FH80011.....	100	FHDC515K.....	60	FHDW3574.....	49	FHLAT820.....	38	FHRBS04.....	40
FH60471.....	114	FH80012.....	100	FHDC527.....	60	FHDW368.....	49	FHLOC158.....	37	FHRBS05.....	40
FH60472.....	114	FH80013.....	100	FHDC5273.....	60	FHDW432.....	59	FHLOC600.....	37	FHRBS06.....	40
FH60480.....	114	FH8DDC.....	84	FHDC528.....	60	FHDW4385.....	58	FHLOC605.....	37	FHRBS10.....	40
FH60481.....	114	FH96401.....	45	FHDC550KA.....	53	FHDW4388.....	58	FHLOC610.....	37	FHRS10.....	50
FH60482.....	114	FHAF6RS.....	85	FHDC616KA.....	51	FHDW4514.....	46	FHMA-12.....	39	FHRS830.....	46
FH60483.....	114	FHAFMDV.....	85	FHDC618KA.....	51	FHDW4523.....	46	FHMA-12-515.....	39	FHRT4210.....	27
FH60484.....	114	FHBAT140.....	61	FHDC9000.....	61	FHDW4619.....	46	FHMA-14.....	39	FHRT428.....	27
FH60500.....	114	FHBAT181.....	61	FHDC900KL.....	57	FHDW4623.....	46	FHMA-14-516.....	39	FHRT5210.....	27
FH60501.....	114	FHBAT411.....	61	FHDC9071.....	61	FHDW4719.....	46	FHMS315.....	37	FHRT528.....	27
FH60502.....	114	FHBC130.....	61	FHDC9091.....	61	FHDW4999.....	46	FHMS315F.....	37	FHSLP20.....	64
FH60520.....	114	FHBC430.....	61	FHDC9096.....	61	FHDW616.....	52	FHMS321.....	37	FHSLS20XP.....	64
FH60521.....	114	FHBM104.....	87	FHDC920KA.....	57	FHDW618.....	52	FHMS321F.....	37	FHSLS25XP.....	64
FH60522.....	114	FHBM84.....	87	FHDC925KA.....	57	FHDW6182.....	52	FHMS360.....	37	FHSNS45XP.....	64
FH60523.....	114	FHBM94.....	87	FHDC926KA.....	57	FHDW6183.....	52	FHMS360F.....	37	FHSS3J5.....	63
FH60524.....	114	FHBOS1617.....	52	FHDC930KA.....	57	FHDW6184.....	52	FHMS370.....	37	FHSX150K-1.....	64
FH60525.....	114	FHBPT1.....	38	FHDC935KA.....	57	FHDW621.....	53	FHMS370F.....	37	FHSXR850.....	68
FH60526.....	114	FHBPT1F.....	38	FHDC9360.....	61	FHDW625.....	53	FHMS410.....	37	FHSXR860.....	68
FH60527.....	114	FHBPT1T.....	38	FHDC936KA.....	57	FHDW660.....	53	FHMS410F.....	37	FHU1042.....	87
FH60528.....	114	FHBPT3F.....	38	FHDC940KA.....	57	FHDW6654.....	55	FHMS411.....	37	FHU1048.....	87
FH60529.....	114	FHBT200K-2.....	64	FHDDR106.....	85	FHDW6655.....	55	FHMS411F.....	37	FHU1242.....	87
FH60530.....	114	FHC766.....	68	FHDDR44.....	85	FHDW670.....	54	FHMSH311.....	37	FHU1248.....	87
FH60531.....	114	FHC780.....	66	FHDDR88.....	85	FHDW6708.....	54	FHMSH321.....	37	FHU1442.....	87
FH60540.....	114	FHC781.....	66	FHDDRRB.....	85	FHDW680K.....	55	FHMSH321F.....	37	FHU1448.....	87
FH60541.....	114	FHC782.....	66	FHDFFC.....	84	FHDW682.....	55	FHMSH360.....	37	FHU1642.....	87
FH60542.....	114	FHC783.....	66	FHDK500.....	37	FHDW6913.....	52	FHMSH360F.....	37	FHU1648.....	87
FH60543.....	114	FHC785.....	67	FHDK510.....	37	FHDW703.....	48	FHMSH370.....	37	FHU842.....	87
FH6100.....	37	FHC789R-26.....	67	FHDK560.....	37	FHDW715.....	48	FHMSH370F.....	37	FHWD462.....	87
FH6100F.....	37	FHC854.....	69	FHDK565.....	37	FHDW716.....	48	FHMSH411F.....	37	FHWD468.....	87
FH62FNK-2.....	65	FHC875.....	69	FHDL1/2.....	38	FHDW718.....	48	FHPB10-CD.....	61	FHWD522.....	87
FH650S4-1.....	64	FHC881.....	69	FHDL1/2F.....	38	FHDW7440.....	46	FHPC100.....	52	FHWD528.....	87
FH7415.....	68	FHC887.....	67	FHDOOR-53.....	38	FHDW7441.....	46	FHPC13700.....	58	FHWD582.....	87
FH7416.....	68	FHCNTA48.....	86	FHDOOR-53T.....	38	FHDW7444.....	46	FHPC2150.....	63	FHWD588.....	87
FH7555.....	68	FHCNTA60.....	86	FHDOOR-57.....	38	FHDW7445.....	46	FHPC3151.....	63		
FH7556.....	68	FHCNTB48.....	86	FHDOOR-60.....	38	FHDW904.....	60	FHPC330.....	59		
FH76401.....	45	FHCNTB60.....	86	FHDOOR-60T.....	38	FHDW9043.....	60	FHPC360.....	59		
FH7701D.....	67	FHCNTU12.....	86	FHDR320.....	37	FHDW906.....	60	FHPC361.....	59		
FH7702.....	69	FHCNTU14.....	86	FHDR320F.....	37	FHDW9063.....	60	FHPC4200.....	52		
FH770224.....	69	FHCNTU16.....	86	FHDR360.....	37	FHDW908.....	60	FHPC511.....	33		
FH770232.....	69	FHCNTX60.....	86	FHDR360F.....	37	FHDW9083.....	60	FHPC513.....	33		
FH7761.....	66	FHCS10.....	49	FHDR370.....	37	FHDW9109.....	61	FHPC517.....	33		
FH7763.....	66	FHD1804.....	33	FHDR370F.....	37	FHDW9116.....	61	FHPC5551.....	55		
FH7763S.....	66	FHD21002.....	56	FHDR410.....	37	FHDW9117.....	61	FHPC5552.....	55		
FH7764EX.....	66	FHD21009.....	56	FHDR410F.....	37	FHDW918.....	60	FHPC5553.....	55		
FH7765.....	68	FHD26451K.....	58	FHDT.....	84	FHDW919.....	60	FHPC5554.....	55		
FH7766.....	66	FHD2670.....	54	FHDUHA1.....	82	FHDW9216.....	61	FHPC557.....	55		
FH7766EX.....	66	FHD28402.....	46	FHDUHA2.....	82	FHDW935K.....	49	FHPC690.....	52		
FH7780.....	69	FHD55153.....	63	FHDUHA2.....	82	FHDW937K.....	50	FHPC691.....	52		
FH7781.....	69	FHD55155.....	63	FHDW140.....	56	FHDW960K-2.....	56	FHPC693PK.....	53		
FH7788.....	67	FHD55170.....	63	FHDW2535.....	43	FHDW965K-2.....	56	FHPC698.....	52		
FH7788A.....	67	FHD55273.....	63	FHDW3103.....	49	FHDW966K-2.....	56	FHPC7310.....	54		
FH7788R.....	67	FHDC011.....	61	FHDW310K.....	50	FHFB100.....	33	FHPC7319.....	54		
FH7788S2-B.....	67	FHDC300K.....	49	FHDW3112.....	49	FHHA50A.....	39	FHPC7335.....	58		
FH80001.....	100	FHDC305K.....	50	FHDW3114.....	49	FHLAT670.....	38	FHPC7518.....	52		

A		
ADHESIVES.....	107	
A-FRAME CART.....	91	
A-FRAME RACK.....	85	
AIR COMPRESSORS.....	62, 63	
AIR DRYERS.....	63	
AIR HOSES.....	70	
AIR TOOL FITTINGS.....	70, 71	
AIR TOOL HOLSTER.....	67	
AIR TOOL OIL.....	68	
ANGLE DRILLS, CORDLESS.....	56	
ANGLE GRINDERS.....	46, 69	
ANTIFATIGUE MATTING.....	105	
ANTIVIBRATION GLOVES.....	109	
AUGER BITS.....	43	
AWL.....	75	
B		
BACK SUPPORTS.....	111	
BAND CLAMP.....	77	
BANDANNAS.....	111	
BANDSAWS.....	30	
BAR CLAMP/SPREADERS.....	77	
BAR CLAMPS.....	77	
BAR RACKS.....	88	
BELT SANDERS.....	59	
BENCH BRUSH.....	105	
BEVERAGE COOLERS.....	114	
BLAST GATES.....	102	
BORE MASTER.....	34	
BORE MASTER JIGS.....	35	
BORE MASTER REPLACEMENT PARTS.....	34	
BOX CUTTERS.....	78	
BRAD NAILERS.....	64	
BRAD NAILS.....	64	
BRAD POINT BITS.....	38	
BRASS BRUSH SET.....	106	
BRISTLE BRUSH SET.....	106	
BROOM.....	105	
BRUSH SETS.....	106	
BUNGEE CORDS.....	99	
C		
CALCULATORS.....	78	
CALIPERS.....	78	
CANTILEVER RACKS.....	86, 88, 89	
CARGO BAGS.....	99	
CARGO BARS.....	99	
CARGO CARRIERS.....	83	
CARGO STRAPS.....	99	
CAROUSELS.....	90	
CAULK GUNS.....	107	
C-CLAMPS.....	76	
CHALK LINE REEL.....	79	
CHISELS.....	75	
CIRCULAR SAWS.....	49, 51	
CLAMPS.....	76, 77	
CLICK'S KWIK DRILL.....	35	
CONTERSINKS.....	43	
CONVEYORS.....	27	
CORDLESS DRILLS.....	56, 57	
CORDLESS TOOL, BATTERIES.....	61	
CORDLESS TOOL, CHARGERS.....	61	
CORNER CHISEL.....	54, 75	
CORNER CLAMP.....	76	
CUP DISPENSERS.....	114	
CUT OUT TOOL BITS.....	53	
CUT OUT TOOLS.....	53	
D		
DEBURRING TOOLS.....	75	
DOCK BUMPERS.....	101	
DOCK LIGHTS.....	101	
DOCKPLATES.....	92, 93	
DOOR & JAMB LEVEL SETS.....	79	
DOOR CART.....	84	
DOOR HINGE TEMPLATE.....	33	
DOOR LITE BITS.....	38	
DOOR PROTECTION/SHIPPING.....	100	
DOOR RACKS.....	85	
DOUBLE SUCTION CUP.....	101	
DOWNDRAFT TABLES.....	102	
DRILLS, CORDED.....	56	
DUCT TAPE.....	108	
DUST COLLECTION ACCESSORIES.....	102, 103	
DUST COLLECTION HOSE.....	103	
DUST COLLECTION SYSTEMS.....	15, 102	
DUST COLLETTION SEPARATORS.....	102	
DUST HOOD.....	102	
DUST PAN.....	105	
DUST SCOOP.....	105	
DUST VAC FITTINGS.....	103	
E		
EAR PLUGS.....	111	
EDGE SANDER BELTS.....	31	
EDGE SANDERS.....	31	
ELBOW FITTINGS.....	103	
ELECTRICAL CABLE PROTECTION.....	112	
ELECTRICAL PLUGS & CONNECTORS.....	112	
ELECTRICAL TAPE.....	108	
E-TRACK.....	99	
EYEWASH STATION.....	114	
EYEWEAR.....	110	
F		
FACE VISOR.....	110	
FANS.....	104, 105	
FENCE PARTITIONS.....	81	
FILE CARD.....	75	
FILE SETS.....	75	
FINGER TAPES.....	109	
FINISH NAILER, CORDLESS.....	51	
FINISH NAILERS.....	65	
FINISH NAILS.....	51, 65	
FINISHING SANDERS, ELECTRIC.....	59	
FIRST AID KITS AND STATIONS.....	114	
FLASHLIGHTS.....	60	
FLOODLIGHTS.....	60	
FLOOR SWEEP.....	103	
FLUSHBOLT TEMPLATE.....	33	
FLUSHBOLT TEMPLATES.....	36	
FOAM BRUSH SET.....	106	
FORK LIFT, FORK EXTENSIONS.....	94	
G		
GATORADE.....	114	
GLOVES.....	109	
GLUE BRUSH SET.....	106	
GLUE GUN.....	74	
GLUE STICKS.....	74	
GLUES.....	107	
GREESE.....	109	
GRINDERS, ELECTRIC.....	46	
GRINDING WHEELS.....	46	
H		
HAMMER DRILLS, CORDLESS.....	57	
HAMMERS.....	74	
HAND TOOL MASTER SETS.....	72	
HAND TRUCKS.....	95	
HANDSCREW CLAMPS.....	76	
HARD HATS.....	110	
HARDWOOD DOLLIES.....	91	
HEX KEY SETS.....	73	
HINGE BUTT TEMPLATE KIT.....	33	
HINGE TEMPLATES.....	36	
HOLE SAW ARBORS.....	42	
HOLE SAWS.....	42	
HOSE CLAMPS.....	103	
HOSE HANGERS.....	103	
HOSE REELS.....	71	
I		
ICE CHEST.....	114	
INSERT BIT HOLDERS.....	45	
INSERT BIT, SCREWDRIVER HANDLE.....	45	
INSERT KNIVES.....	45	
J		
JIG SAW BLADES.....	47	
JIG SAWS.....	47	
JITTERBUG PNEUMATIC SANDERS.....	68	
JOBBER DRILLS.....	43	
JOINTER CLAMPS.....	76	
JOINTERS.....	29	
K		
KERFING BLADES.....	45	
KEVLAR GLOVES.....	109	
KNEE PADS.....	111	
L		
LADDER RACKS.....	82	
LADDERS.....	90	
LAMINATE TRIMMER ACCESSORIES.....	54	
LAMINATE TRIMMERS.....	54	
LATCH BITS.....	38	
LATCH FACE TEMPLATES.....	36	
LEATHER GLOVES.....	109	
LEVELS.....	79	
LOCK BORING BITS.....	37	
LOCK CAGE.....	81	
LOCK FACE TEMPLATE.....	33	
LOCK INSALLATION KITS.....	33, 34, 35	
LOCK MORTISER.....	33	
LOCKOUT CENTERS.....	113	
LOCKOUT HASP.....	113	
LOCKOUT LOCKS.....	113	
LOCKOUT SIGN.....	113	
LOCKOUT TAGS.....	113	
LOCTITE.....	109	
LUBRICANTS.....	109	
M		
MASKING TAPE.....	108	
MEASURING TAPES.....	79	

MEASURING WHEEL.....	79
MITER SAWS.....	48, 51
MOULDING CART.....	84
MOULDING RACK.....	85
MULTI SPUR BITS.....	37

N	
NAIL PULLERS.....	74
NAIL SET.....	75
NASCO BITS.....	45
NITRILE GLOVES.....	109
NUTSETTER, MAGNETIC SHANKS.....	45
NYLON BRUSH SET.....	106

O	
ORBITAL SANDER, REPLACEMENT PADS.....	58, 68
ORBITAL SANDERS, ELECTRIC.....	58
ORBITAL SANDERS, PNEUMATIC.....	68

P	
PADDLE SWITCH.....	112
PAINTER'S TAPE.....	108
PALLET BUSTER.....	101
PALLET RACKS.....	87
PALLET TRUCKS.....	94
PALM GRIP AIR HAMMER.....	69
PALM GRIP AIR NAILER.....	69
PANEL CART.....	91
PANEL SAWS.....	32
PHILLIPS INSERT BITS.....	44
PHILLIPS POWER BITS.....	44
PLANERS.....	29, 55
PLANERS.....	75
PLATE JOINERS.....	55
PLATE JOINING BISCUITS.....	55
PLATFORM TRUCKS.....	95
PLIERS.....	73
PLUNGE ROUTERS.....	53
PNEUMATIC BLOW GUN.....	71
PNEUMATIC BLOW GUN KIT.....	71
PNEUMATIC COUPLERS AND MANIFOLDS.....	71
PNEUMATIC DRILLS.....	67
PNEUMATIC SCREWDRIVERS.....	66
PNEUMATIC STAPLERS.....	64
POLYURETHANE MELT GUN.....	108
POWER CORDS.....	112
PRODUCT INDEX.....	
PRY BARS.....	74
PUNCHES.....	75
PUSH BLOCKS.....	109
PUSH STICK.....	109

R	
RADIAL ARM SAWS.....	46
RASP SETS.....	75
RATCHETING WRENCH SETS.....	73
RECIPROCATING MINI AIR SAW.....	69
RECIPROCATING MINI SAW BLADES.....	69
RECIPROCATING SAW BLADES.....	50
RECIPROCATING SAWS.....	49
REDUCER FITTINGS.....	103
RESPIRATORS.....	111
ROLLER BUILD TABLE.....	27
ROLLER WORK STANDS.....	27
ROTARY SCREW COMPRESSORS.....	62
ROUTER BITS.....	39, 40, 41, 42
ROUTER TEMPLATE GUIDES.....	41, 52

ROUTERS.....	52
RUBBER MALLETS.....	74
S	
SAFETY EYEWEAR.....	110
SANDERS.....	58, 59, 68
SANDERS, ELECTRIC.....	46
SANDING BELTS.....	59
SANDING DISCS.....	58
SANDING SHEETS.....	59
SAW BLADES, MITER/CIRCULAR.....	49, 51
SCISSOR DOCK LIFT.....	93
SCREWDRIVERS.....	73
SEALANTS.....	107
SEATBANDS.....	111
SELF CENTERING BITS.....	45
SHANKS FOR MORTISE BITS.....	39
SHAPERS.....	31
SHEET RACKS.....	88
SHELVING UNITS, STAINLESS STEEL.....	89
SHOP FLASH.....	112
SHOP VACS.....	105
SLIDING ARM CLAMPS.....	76
SLOTTED INSERT BITS.....	44
SLOTTED POWER BITS.....	44
SLOTING CUTTERS.....	45
SOCKET HEX HEAD INSERT BITS.....	44
SOCKET SETS.....	72
SPADE BITS.....	43
SPLICE FITTINGS.....	103
SPRING CLAMPS.....	76
SQUARE DRIVE SOCKET ADAPTORS.....	45
SQUARE INSERT BITS.....	44
SQUARE POWER BITS.....	44
SQUARE, CARPENTER.....	79
STACKABLE BAR CRADLES.....	89
STACKABLE RACKS.....	85, 89
STAPLE GUNS.....	74
STAPLES.....	64
STEEL HOPPER CASTERS.....	97
STEEL HOPPER POLY LIDS.....	97
STEEL HOPPERS.....	96, 97
STEP MATE STANDS.....	90
STOCKPICKER TRUCKS.....	96
STRAPPING CART.....	98
STRAPPING TOOLS.....	98
STRETCH WRAP MACHINES.....	98
STRETCH WRAPS.....	98
STRIKE & LATCH TEMPLATE.....	33

STRIKE TEMPLATES.....	36
STUD SENSOR.....	78
T	
TABLE SAWS.....	28, 29, 46
TACK HAMMER.....	74
TAPES.....	108
T-FITTINGS.....	103
TOOL BAGS.....	80
TOOL BALANCER.....	67
TOOL BELTS.....	80
TOOL BOXES.....	80
TORX INSERT BITS.....	44
TORX POWER BITS.....	44
TREE CART.....	84
TRUCK MOUNTED STRAP WINCHES.....	98
TRUCK RACKS.....	83
TRUCK STORAGE.....	82
U	
UNDERCUT SAW.....	75
UNI SAW.....	42
UTILITY KNIVES.....	78
V	
VACUUMS.....	60
VAN RACKS.....	82
VERTICAL RACKS.....	88
VIX BITS.....	45
W	
WAREHOUSE MIRRORS.....	101
WATER COOLERS.....	114
WHEEL MARKING GAUGE.....	78
WIDE BELT SANDER BELTS.....	31
WIDE BELT SANDERS.....	31
WOOD FILLERS.....	107
WORK MATE STANDS.....	90
WORKSITE CHESTS.....	80
WRENCH SETS.....	73
WRIST WRAPS.....	109
Y	
YARD RAMPS.....	93
Y-FITTINGS.....	103

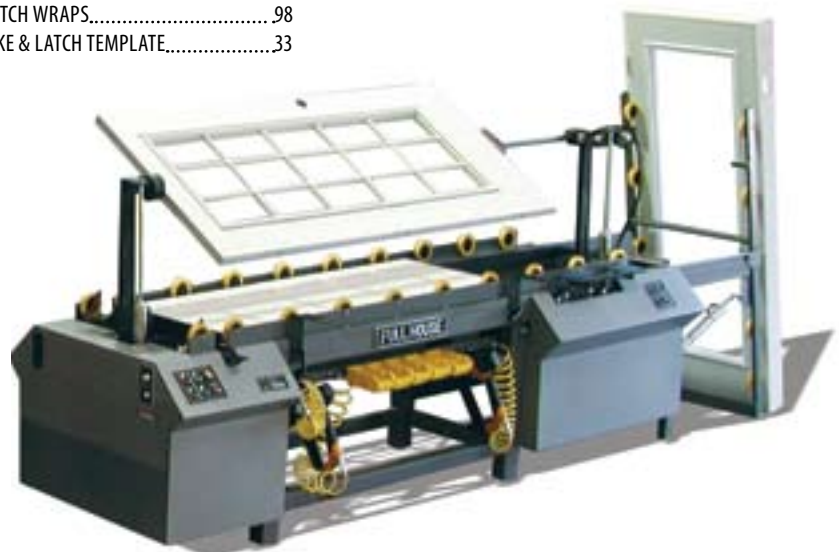

**8:00 AM - 5:00 PM M-F
EASTERN STANDARD TIME**

By Phone:

Call us at our Melbourne, Florida factory Mon. -Fri., between the hours of 8:00 am and 5:00 pm Eastern Standard Time
Toll Free (800) 325-8352 or (321) 752-8180

E-mail: supply@full-house.com

Website: www.full-house.com

Fax: (321) 752-8116

Mail: Full House Company
320 North Drive
Melbourne, Florida 32934 USA



INTRODUCTION

Full House Company is constantly pursuing the best products possible. All product descriptions within this catalog are to the best of our knowledge at time of publication. If you need verification of critical dimensions, please request a detail drawing of the product.

PURCHASE ORDERS

When ordering by phone, fax, mail or e-mail, include the following:

- Purchase order number and name of person authorized to purchase
- Shipping address if different than the billing address
- Complete phone and fax numbers including the area code
- If it is your policy to issue a confirming order following phone orders be sure it is marked **CONFIRMING**
- **Model Number** of items being ordered
- Description, Quantity, Size...ect.
- All prices are noted in US dollars

NEW ACCOUNTS

Open account terms of NET 30 days from the day of shipment are extended to companies listed with a satisfactory rating from Dun and Bradstreet. Unrated or unlisted companies are required to submit a completed Full House Application for Credit. Buyer may expedite an order, while on open account status, by including payment with order.

Thoroughly inspect all items for shipping damage before accepting delivery. If damage has occurred, buyer should note the extent of the damage on the freight bill and call Full House immediately. File claim with carrier immediately. Terms inconsistent with those stated herein which may appear on Purchaser's formal order will not be binding on the Seller.

Contact factory for individual product warranty. Warranty does NOT cover labor or consequential damages including but not limited to business interruption costs, labor profits, lost business opportunities, ect.

Customer is responsible to check correctness of fit for applications.

Freight, site preparation, installation, execution and training are not included.

All specifications noted in this publication are subject to change without notice.

RETURNS

If for any reason you are dissatisfied with a product you receive from Full House, call us for shipping instructions to return it within 30 days (Products are non-returnable after 30 days). Custom orders are non-returnable. All returns are subject to a restocking fee and/or refurbishing fee. Contact factory for authorization prior to any return. **All returns without a Return Goods Authorization number (RGA) will not be accepted.**

FREIGHT CLASS AND WEIGHTS

Unless otherwise specified, all orders will ship best way prepaid and add, F.O.B. shipping point. • Freight call may vary depending on the carrier and quantity ordered for density based items. Weights shown do not include packaging, pallet or crating weights. All freight is subject to reclassification if not shipped prepaid & add. For freight estimates and FOB shipping point verification contact a Full House representative.

CUSTOM FABRICATION

Custom fabrications are non-returnable and may require a 50% deposit before production.

FAX ORDER FORM

FAX US AT: 1(321) 752-8116



FULL HOUSE ♦ SUPPLY

320 North Drive, Melbourne, FL 32934
1.800.325.8352 ♦ 321.752.8180

ATTENTION: _____

MAILING/BILLING ADDRESS

Company _____
 Contact Name _____
 Address _____
 City/State/Zip _____
 Phone _____
 Order Date _____

SHIPPING ADDRESS

Company _____
 Contact Name _____
 Address _____
 City/State/Zip _____
 Phone _____

ORDER TOLL-FREE 1.800.325.8352 or 321.752.8180

SALES REPRESENTATIVES AVAILABLE 8 A.M. TO 5 P.M. EASTERN TIME

SHIP VIA

- U.P.S. GroundTrac
- FedEx Economy
- FedEx Priority
- U.P.S. Next Day Air
- U.P.S. Second Day Air
- U.P.S. 3-Day Select

QTY	MODEL	DESCRIPTION	UNIT PRICE	SHIPPING WT	TOTAL

METHOD OF PAYMENT

- Established Open Account PO # _____
- Charge my: MasterCard Visa American Express

CARD NUMBER _____

EXP DATE _____

Cardholder Name _____

Signature _____ Date _____

SUB-TOTAL	_____
STATE SALES TAX	_____
FREIGHT TOTAL*	_____
TOTAL	_____

Fax confirmation needed Fax # _____

FULL HOUSE SUPPLY CARRIES THESE BRANDS:



BOSCH

BOSTITCH



DURACELL



igloo

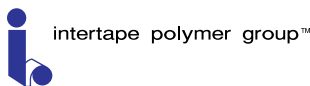

IRWIN



LEGACY

LOCTITE



Trakita

Master Lock

metabo



Rotacator

RUST-OLEUM BRANDS



SENCO



SIEMENS



STANLEY

Starrett



WATERLOO



FHS Services

Call 1-800-325-8352
M-F • 8 am to 5 pm EST

SET-UP & TRAINING

Full House can set-up your machinery and train your employees on the operation and proper daily maintenance.

SERVICE PROGRAMS

We offer on-site, telephone and internet service to keep your machines running at peak performance.

LEASE PROGRAMS

Have a big project coming up? Full House has a leasing program to help you when you need it most.

TRADE-INS

Want to upgrade? Full-house will buy back some used machinery.

REBUILT MACHINERY

Full House has a wide range of brand name equipment in stock, ready to be rebuilt. All rebuilt equipment is completely stripped to the bare frame and rebuilt using new routers, motors, air lines and cylinders. All machines have a six month warranty.

SHOP LAYOUT

Full House offers assistance in shop layout and material flow. With years of experience in over 1,000 door shops, we can help you layout your shop for maximum efficiency.

CUSTOM PROJECTS

Full-House designs and manufactures custom machinery & material handling items, such as racks, carts and tables. Call today with the custom size you need.

Can't find what you are looking for?

Call us! We can source and supply many other products from the companies we represent.

Replacement Parts and Supplies



Full House has a complete inventory of replacement parts and supplies to keep your production running smoothly. With years of experience in this industry we have learned the importance of having the proper parts. We have a toll free line for easy ordering and overnight shipping is available in most circumstances.

Call Today!

1-800-325-8352 • Ask for the Service Department



FULL HOUSE ♦ SUPPLY

Full House Company
320 North Drive
Melbourne, FL 32934
www.full-house.com

Toll Free: 1-800-325-8352
Email: supply@full-house.com
Fax: 1-321-752-8116

